



ISO 9001  
ISO 14001  
PN-N-18001  
OHSAS 18001



COMMON S.A.  
ul. Aleksandrowska 67/93  
91-205 Łódź  
tel.: +48 42 253 66 00  
tel.kom.: +48 601 255 580  
fax: +48 42 253 66 99  
e-mail: common@common.pl

# QUANTOMETERS

series

**CPT-01**

## OPERATION MANUAL



**CPT – OM – 18**

April 2018

---

**PRIOR TO INSTALLATION AND START-UP READ CAREFULLY  
THESE INSTRUCTIONS**

## *Contents*

	<i>Page</i>
<i>I. DESIGN AND APPLICATION CONDITIONS</i>	<i>2</i>
<i>II. CONSTRUCTION AND OPERATION</i>	<i>5</i>
<i>III. INDEX AND MEASUREMENT OUTPUTS</i>	<i>7</i>
<i>IV. MARKING AND CALIBRATION OF QUANTOMETERS</i>	<i>14</i>
<i>V. PACKAGING, TRANSPORTATION AND STORAGE</i>	<i>18</i>
<i>VI. INSTALLATION AND START-UP</i>	<i>24</i>
<i>VII. MAINTENANCE, FAULTS , REPAIRS</i>	<i>29</i>
<i>VIII. AUXILIARY EQUIPMENT</i>	<i>30</i>
<i>DECLARATION OF CONFORMITY</i>	

## I. DESIGN AND APPLICATION CONDITIONS

### Design

CPT-01 Turbine Quantometers are instruments used for measurement of gas volume that flows through an installation. Standard version allows to be installed where explosion hazard zones may occur (air and gas mixtures - class IIA and class IIB; with special version – also class IIC). The CPT-01 Quantometers may be used for measurement of gases indicated in Table 1. Using the CPT-01 Quantometers for measurement of other gases has to be agreed with the manufacturer. Maximum operating pressure for the CPT-01 Quantometers is 2 MPa. Turbine quantometers in standard version are installed between PN16 or PN20 (ANSI150) flanges of the pipework, as an option they can be equipped with threaded connections or flanges. It is recommended to install the gas meters in compartments with stable temperature, but they are also suitable for outdoor installations. CPT-01 turbine quantometers in standard version are maintenance free devices, because the bearings used in them have a supply of lubricant. As an option, CPT-01 turbine quantometers (from DN65 to DN200) may be adapted for external lubrication.

### Application conditions of CPT-01 Quantometers.

#### 1. Conformity with the requirements of the ATEX Directive 2014/34/EU:

- |                            |    |   |
|----------------------------|----|---|
| - certificate              |    | KDB 04ATEX035, annex No 1, No 2 and No 3  |
| - CE marking               | CE | 1453, Central Mining Institute, Experimental Mine "Barbara"                                   |
| - application conditions   |    | standard version     ⓧ II 2G Ex ia IIB T5 Gb<br>special version       ⓧ II 2G Ex ia IIC T5 Gb |
| - index housing protection |    | IP66/IP67,  |
| - ambient temperature      |    | $-25^{\circ}\text{C} \leq T_a \leq +70^{\circ}\text{C}$                                       |
| - harmonized standards     |    | EN 13463-1:2009,<br>EN 60079-0:2012,<br>EN 60079-11:2012                                      |

#### 2. IECEx Certificate of Conformity

- |                         |  |   |
|-------------------------|--|---|
| - certificate           |  | IECEX KDB 15.0004   |
| - marking               |  | standard version     Ex ia IIB T5 Gb<br>special purpose version   Ex ia IIC T5 Gb |
| - ambient temperature   |  | $-25^{\circ}\text{C} \leq T_a \leq +70^{\circ}\text{C}$                           |
| - harmonized standards: |  | IEC 60079-0: ed 6<br>IEC 60079-11: ed 6   |

#### 3. Conformity with the requirements of the PED Directive 2014/68/EU:

- |                              |    |   |
|------------------------------|----|---|
| - certificate                |    | 60775/JN/001/04,  |
| - CE marking                 | CE | 1433, Office of Technical Inspection  |
| - maximum operating pressure |    | $P_{\max} = 2\text{ MPa}$ ,   |
| - ambient temperature        |    | $-25^{\circ}\text{C} \leq T_S \leq +70^{\circ}\text{C}$                             |
| - storage temperature range  |    | $-30^{\circ}\text{C} \leq t_s \leq +70^{\circ}\text{C}$                             |
| - harmonized standards       |    | EN 12392:2002, EN 10269:2013  |
| - other applied regulations  |    | Requirements of Office of Technical Inspection.<br>Pressure equipment. WUDT/UC/2003 |

#### 4. Conformity with the requirements of the EMC Directive 2014/30/EU:

Requirements met by the use of LF and HF pulse emitters (NAMUR) compliant with the following harmonized standards: EN 60947-5-2:2007, EN 60947-5-6:2000).

5. Accuracy class 1,5 (OIML R 137-1&2:2012 (E) table 2)
6. Metrology parameters see Table 2
7. Operating position HV (horizontal or vertical)
8. Conformity with other standards PN-EN 12261:2003

*Table 1. Physical properties of most popular gases that may be measured with the CPT-01 Quantometers - density at 101,325 kPa, and at 20° C*

Gas or gas mixture	Chemical symbol (formula)	Density $\rho$ [kg/m <sup>3</sup> ]	Density relative to air	Gas meter version
argon	Ar	1.66	1.38	standard IIB
nitrogen	N <sub>2</sub>	1.16	0.97	standard IIB
butane	C <sub>4</sub> H <sub>10</sub>	2.53	2.1	standard IIB
carbon dioxide	CO <sub>2</sub>	1.84	1.53	standard IIB
ethane	C <sub>2</sub> H <sub>6</sub>	1.27	1.06	standard IIB
ethylene	C <sub>2</sub> H <sub>4</sub>	1.17	0.98	standard IIB
natural gas	≈CH <sub>4</sub>	ca. 0.75	ca. 0.63	standard IIB
helium	He	0.17	0.14	standard IIB
methane	CH <sub>4</sub>	0.67	0.55	standard IIB
propane	C <sub>3</sub> H <sub>8</sub>	1.87	1.56	standard IIB
carbon monoxide	CO	1.16	0.97	standard IIB
acetylene	C <sub>2</sub> H <sub>2</sub>	1.09	0.91	special IIC
hydrogen	H <sub>2</sub>	0.084	0.07	special IIC
air	–	1.20	1	standard IIB

### Pressure loss

Turbine quantometer is causing a pressure loss in the installation. The maximum value of this  $\Delta p_{\max}$  pressure loss is for each CPT-01 turbine quantometer is described in Table 2.

**$\Delta p_{\max}$  value was determined by air at density  $\rho_o = 1,2$  [kg/m<sup>3</sup>] for  $Q_{\max}$  gas flow.**

In actual conditions the  $\Delta p_{rz}$  [mbar] pressure loss can be calculated using the following formula:

$$\Delta p_{rz} = \frac{\rho}{\rho_o} \cdot \frac{p_a + p}{p_a} \cdot \left( \frac{Q_{rz}}{Q_{\max}} \right)^2 \cdot \Delta p_{\max} \quad [mbar]$$

where:  $\rho$  - gas density according to Table 1 [kg/m<sup>3</sup>],

$\rho_o = 1,2$  [kg/m<sup>3</sup>] density of air,

$p_a$  - atmospheric pressure ( $p_a \cong 1013$  [mbar] ),

$p$  - gauge gas pressure measured on the quantometer's inlet [mbar],

$\Delta p_{\max}$  - maximum pressure loss (according to Table 2) [mbar],

$Q_{\max}$  - maximum flow for specified quantometer (according to Table 2) [m<sup>3</sup>/h],

$Q_{rz}$  - flow at actual conditions [m<sup>3</sup>/h]

Table 2. Basic metrological parameters and digital codes of the CPT-01 Quantumeters

Nominal diameter (connection thread) DN	Gas meter size G	Maximum flow $Q_{max}$	Pressure loss at $Q_{max}$ $\Delta p_{max}$	$Q_{min}$ Minimum flow at rangeability			Emitter constant (for HF approximate)		
				1:10	1:20	1:30	LF	HF1, HF2	HF3
-	-	[m <sup>3</sup> /h]	[mbar]	[m <sup>3</sup> /h]	[m <sup>3</sup> /h]	[m <sup>3</sup> /h]	[imp/m <sup>3</sup> ]	[imp/m <sup>3</sup> ]	[imp/m <sup>3</sup> ]
DN 25 (1" or 1¼")	G 16	25	4	2,5	-	-	10	9770	113600
	G 25	40	4	4	-	-		8710	101300
DN 32 (1¼")	G 25	40	3,2	4	-	-	10	8925	103800
DN 40 (G1½")	G 40	65	2,5	6,5	-	-	10	2610	94830
	G 65	100	5,0	10	5	-		2610	94830
DN 50 (G2") DN 50	G 40	65	2,5	6,5	-	-	10	2610	94830
	G 65	100	5,0	10	5	-		2610	94830
DN 65	G 65	100	1,6	8	-	-	10	1081	42560
	G 100	160	3,8	16	8	-	1	1081	42560
DN 80	G 100	160	3,7	16	8	-	1	1081	42560
	G 160	250	5,4	25	13	8		844	30650
	G 250	400	11,4	40	20	13		470	17060
DN 100	G 160	250	3,7	-	13	8	1	692	16780
	G 250	400	4,2	-	20	13		692	16780
	G 400	650	8,8	-	32	20		401	9720
DN 150	G 400	650	2,4	-	32	20	1	227	6870
	G 650	1000	6,4	-	50	32		227	6870
	G 1000	1600	16,0	-	80	50	0,1	129	3910
DN 200	G 650	1000	2,0	-	50	32	1	114	3110
	G 1000	1600	6,0	-	80	50		0,1	116
	G 1600	2500	15,0	-	130	80	67		2025

## II. CONSTRUCTION AND OPERATION

The turbine quantometer operation is based on the proportionality of the rotational speed of the turbine wheel to the linear velocity thus to the flowing gas volume. Gas entering the meter (Fig. 2) is directed through the inlet flow straightener into the measurement assembly and causes the rotation of the turbine wheel. The wheel rotations are transmitted by means of gears and magnetic coupling into the index assembly. The volume that has flown through the meter is counted and is shown on the 8-digit counter. Proper performance of each CPT-01 Quantometer is maintained only in the range of  $Q_{\min}$  and  $Q_{\max}$ , as determined in Table 2.

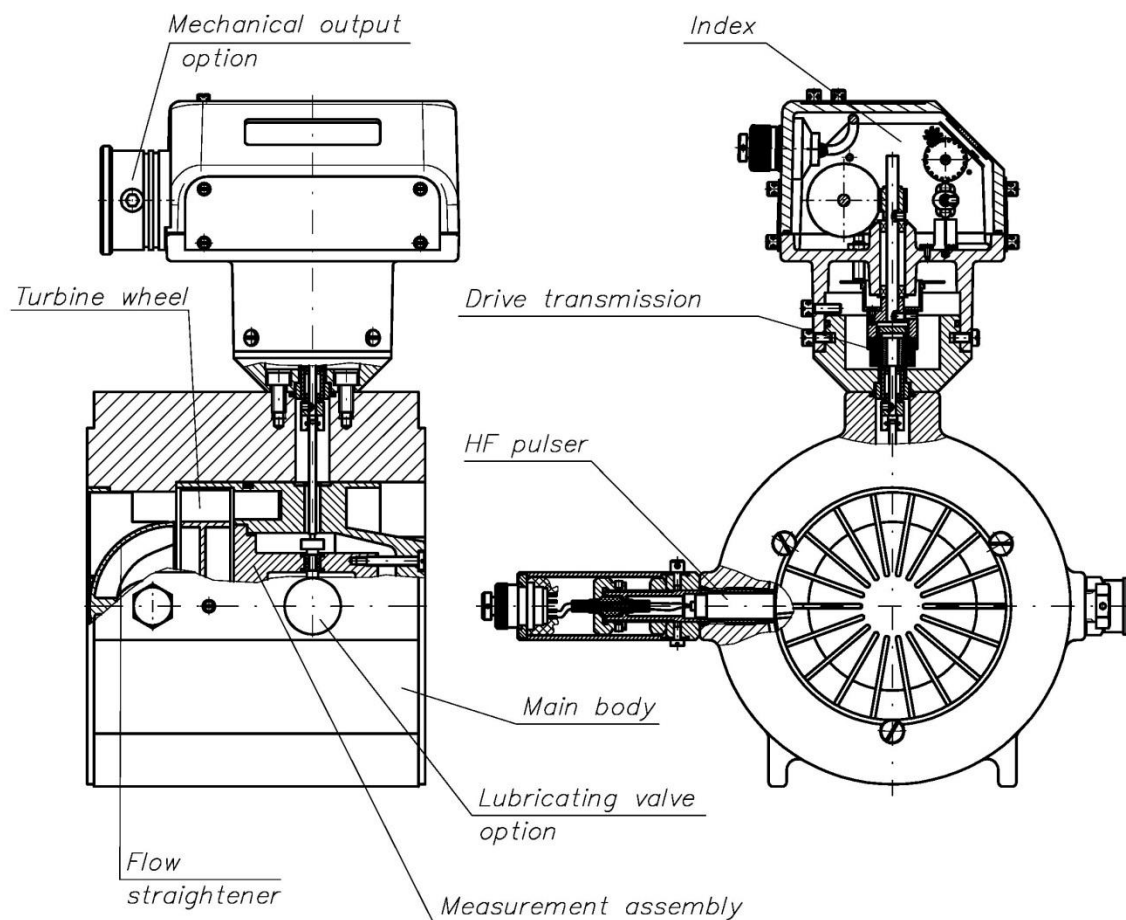

Fig.1. Cross section of the CPT-01 Quantometer

The CPT-01 Quantometer (Fig. 1) consists of four main assemblies:

**1. Main body assembly.** The main body assembly consists of the main body made of extruded aluminum profile, inlet straightener and plugs for taps. The main body is equipped with the pressure measurement tap and the tap for installation of the HF inductive transmitter. As an option the main body can be equipped with socket for thermowell and socket for external lubrication. The inlet straightener, placed upstream the turbine wheel, distributes evenly the gas flow and directs it onto the turbine wheel vanes. As an option the main body can be equipped with threaded connections or flanges.

**2. Measurement assembly.** It consists of the turbine wheel, the turbine wheel housing, the measurement assembly housing, shafts and gears. The turbine wheel is placed in the axis of the quantometer body and is provided with high precision bearings. The standard version uses bearings with a supply of grease. Optionally, measuring units, from DN65 to DN200, can be adapted for external lubrication. The transmission gear (worm gear and cylindrical gear) decreases the rotational velocity and transfers it to the magnetic coupling..

**3. Drive transmission assembly.** It is installed in the quantometer body. It consists of the mount with the hermetic, gas tight partition and the magnetic coupling. The driving part of the magnetic coupling is placed inside the quantometer and is connected with the turbine assembly by means of an articulated shaft. The driven part of the magnetic coupling is placed outside the partition and is connected with the index.

**4. Index assembly.** Consecutive reduction of the rotational speed is performed there (through the worm gear and cylindrical gear) in order to drive the mechanical totalizer, and inductors of low frequency pulse transmitters. The assembly contains also sockets for electric LF and HF output signals. The name plates are placed on the counter cover. The index unit can be equipped with a mechanical output for driving external devices. The optional CWSL Encoder in the CWSL-N, CWSL-A, CWSL-M versions can be connected to the optional mechanical output. The data sent from the CWSL-N Encoder is consistent with the quantometer's index.

As a standard the CPT-01 quantometers are not lubricated externally. Optionally, from DN65 to DN200, they can be equipped with a special lubrication valve. There is a sticker on the lid of the lubrication valve plug showing the type of oil to be used. The remaining mechanisms of CPT-01 flowmeters are not lubricated externally, however bearings with lubricant supply are used.

### III. INDEX AND MEASUREMENT OUTPUTS

The reading assemblies of the CPT-01 Quantometer consist of a mechanical index with incorporated electric signal outputs, a pressure tap and a tap for installation of an external HF pulse transmitter (from the turbine wheel). These outputs enable the control of the instrument operation and connections of external devices. Location of measurement outputs on the quantometer is shown in the Fig. 2.

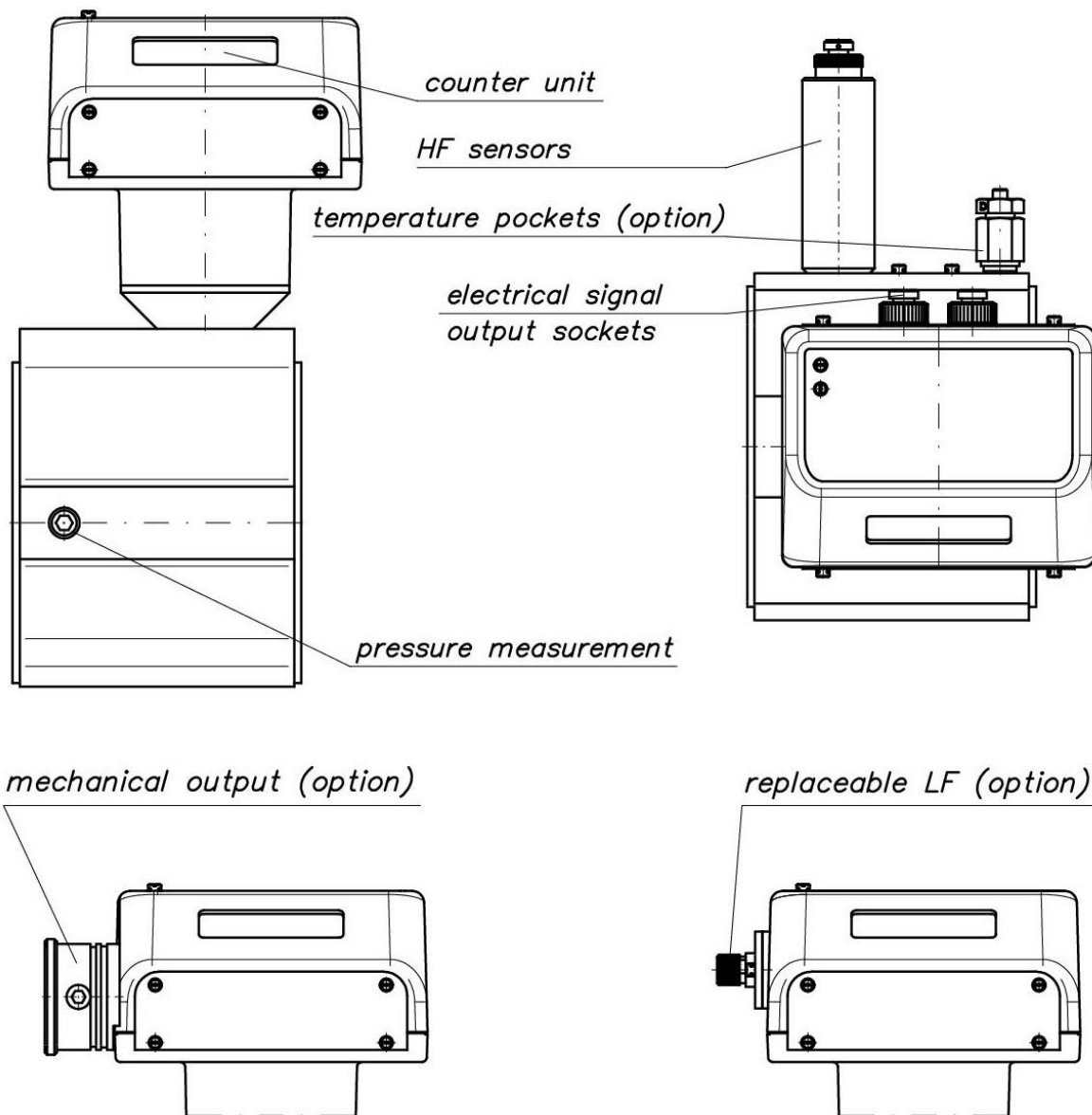

Fig.2. Location of the measurement outputs on the CPT-01 Quantometer

**Mechanical counter** is located inside the index unit and is visible through the polycarbonate sight glass. It enables direct reading of the gas volume flowing through the meter at operating conditions, i.e. at actual pressure and temperature. The index unit may be rotated by 350° against its axis what enables reading of the index from any direction.

**Mechanical counter output.** The Quantometer may be optionally equipped with a mechanical output. A flattened tip of the counter shaft is located on the left side of the index head



and covered by a protective cap. The mechanical output (Fig. 3a) may be used to drive external devices. The rotational speed of the shaft is identical to the speed of the fastest counter drum. The shaft rotates in a clockwise direction. Maximum allowable momentum on the output shaft tip is 0.25 Nmm (Fig. 3b).

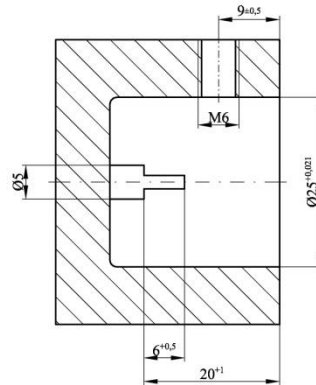
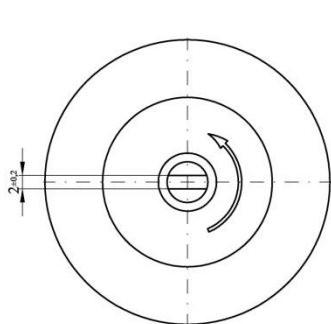

Fig. 3a. Mechanical output dimensions

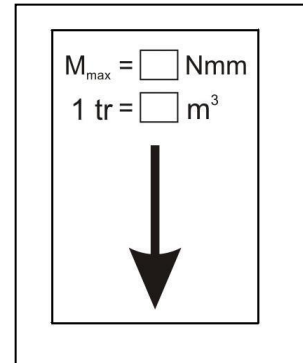

Fig. 3b.

**Electrical counter outputs.** There are two possible types of electric signal outputs: low frequency (LF) outputs and high frequency (HF) outputs. The index head can be equipped with one or two 6-pins sockets. Up to three electric pulse emitters can be connected to each of the sockets. The pulse emitters are:

- one or two inductive high frequency emitters HF,
- one or two inductive low frequency emitters LFI,
- one or two low frequency reed contact emitters LFK,
- one low frequency emitter LFW equipped with Wiegand sensor only for versions following the certificate No. IECEx KDB 15.0004
- one control circuit utilizing normally closed reed relay switch AFK.

The reed relay emitters LFK and LFW are designed to work with a battery-powered or grid/battery-powered data logger and volume converter located in the vicinity of the meter (up to ca. 2 m). The induction emitters, both of the LFI and the HF type, may emit electric current signals over significantly longer distances (up to ca. 200 m, depending on conditions). Due to high power consumption, they are designed to work only with grid-powered volume converters. Gas volumes corresponding to individual pulses of the LF emitter are presented in Table 2. Number of HF pulses for one m<sup>3</sup> of gas is determined individually for each gas meter, and is indicated in the name plate.





**A dash placed in the name plate instead of number of pulses, or lack of description, indicates that an appropriate pulse transmitter has not been installed.**

All pulse transmitters installed in the index head are connected to contacts of „Tuchel” C091 31N006 100 2 or “Lumberg” 0304 06 sockets. The sockets are located on the rear side of the index head. These sockets are to be used for connection of 6-pin plugs “Tuchel” C091 31H006 100 2 or “Lumberg” 0332 06. The connection applied in the CPT-01 Quantumeters are IP67. Possible connections of transmitters with appropriate electric signal sockets are given in Table 3.

**Table 3. Possible connections of transmitters to electric output sockets.**

	Pin	Polarity	LFK 1 or LFW 1	LFK 2 or LFW 2	AFK	(*) LFI 1	(*) LFI 2	HF 1	HF 2
Socket 1	1	-	S			O			
	4	+		S		O			
	2	-			O	P	O		O
	5	+			O	P	O		O
	3	-				O		P	
	6	+				O		P	
Socket 2	1	-		P		O			
	4	+		P		O			
	2	-		O	O	O	P		O
	5	+		O	O	O	P		O
	3	-						O	P
	6	+						O	P
S – standard connections, P – preferred connections, O – optional connections (*) – not available with replaceable LF sensors The view and numbering of the pins Sockets 1 and 2 is shown in Fig. 8 (9).									
<b>Standard versions of the CPT-01 quantometers features only one low frequency reed contact emitter LFK 1</b>									

According to the application conditions the CPT-01 Quantometers should be provided with transmitters of at least  II 2G Ex ib IIC T5 Gb protection level. These conditions are met when the following pulse transmitters are used:

- HF type Bi1-EG05-Y1<sup>(1)</sup> by Hans Turck GmbH  
 Certificate No. IECEx KEM 06.0036X marking Ex ia IIC T4... T6  
 Certificate No. KEMA 02ATEX1090X marking  II 1G Ex ia IIC T4...T6 or  II 2G Ex ia IIC T4...T6
- LFI type Si5-K09-Y1<sup>(1)</sup> by Hans Turck GmbH  
 Certificate No. IECEx KEM 06.0036X marking Ex ia IIC T4... T6  
 Certificate No. KEMA 02ATEX1090X marking  II 1G Ex ia IIC T4...T6 or  II 2G Ex ia IIC T4...T6
- LFK type CLFK-03 by Common S.A.
- LFW type CLFW-01 by Common S.A. <sup>(2)</sup>

(1) – required linear characteristics of the emitter power circuit.

(2) – only for versions following the certificate No. IECEx KDB 15.0004

**Acceptable intrinsic safety parameters**

<b>Bi1-EG05-Y1</b>	<b>Si5-K09-Y1</b>	<b>CLFK-03</b>	<b>CLFW-01 CLFW-02</b>
<b>U<sub>i</sub> = 20 V DC</b>	<b>U<sub>i</sub> = 20 V DC</b>	<b>U<sub>i</sub> = 15.5 V DC</b>	<b>U<sub>i</sub> = 30 V DC</b>
<b>I<sub>i</sub> = 60 mA</b>	<b>I<sub>i</sub> = 60 mA</b>	<b>I<sub>i</sub> = 52 mA</b>	<b>I<sub>i</sub> = 52 mA</b>
<b>P<sub>i</sub> = 200 mW</b>	<b>P<sub>i</sub> = 130 mW</b>	<b>P<sub>i</sub> = 169 mW</b>	<b>P<sub>i</sub> = 0.6 W</b>
<b>L<sub>i</sub> = 150 μH</b>	<b>L<sub>i</sub> = 350 μH</b>	<b>L<sub>i</sub> ≈ 0</b>	<b>L<sub>i</sub> ≈ 0</b>
<b>C<sub>i</sub> = 150 nF</b>	<b>C<sub>i</sub> = 250 nF</b>	<b>C<sub>i</sub> ≈ 0</b>	<b>C<sub>i</sub> ≈ 0</b>

**ATTENTION!**

**The total voltage of separate galvanic intrinsically safe circuits connected to one connector must comply with: U<sub>i1</sub> + U<sub>i2</sub> ≤ 30 V**

Intrinsic safety parameters of the emitters installed in the gas meter are listed on the type plate.

**The security level is also met by the following interchangeable transmitters:**

- LFK type CLFK-04 manufactured by Common S.A.
- LFW type CLFW-04 manufactured by Common S.A.

**Acceptable intrinsic safety parameters**

CLFK-04	CLFW-04
$U_i = 15.5 \text{ V DC}$	$U_i = 30 \text{ V DC}$
$I_i = 52 \text{ mA}$	$I_i = 52 \text{ mA}$
$P_i = 169 \text{ mW}$	$P_i = 0.6 \text{ W}$
$L_i \approx 0$	$L_i \approx 0$
$C_i \approx 0$	$C_i \approx 0$

**Electrical outputs from HF transmitter installed in the CPT-01 Quantometer body**

The high frequency transmitter may be installed in the quantometer body, over the turbine wheel. The turbine wheel is the modulating element of the HF transmitter magnetic field.

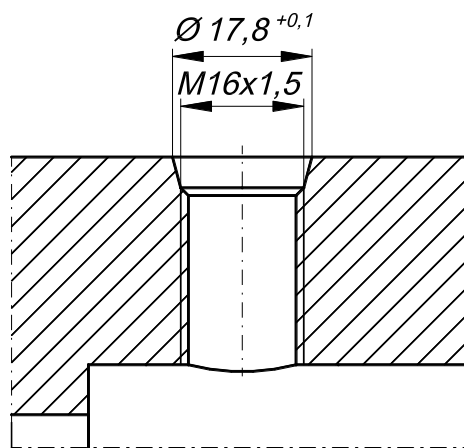

Fig.4. Dimensions of the HF transmitter tap in the quantometer body.

The pulse transmitter is installed in the tap shown in Fig.2. The tap is provided with M16 x 1,5 thread.

**INSTALLATION OF THE HF TRANSMITTER IN THE GAS METER BODY REQUIRES HIGH ACCURACY. ALSO SPECIAL ELECTRONIC CONTROL DEVICES SHOULD BE USED. THEREFORE IT MAY ONLY BE PERFORMED BY THE MANUFACTURER OR BY THE AUTHORIZED REPRESENTATIVE.**

The protection type of the transmitters should be at least  $\text{Ex II 2G Ex ib IIC T5 Gb}$ . These conditions are met by the following transmitters:

**CHFI-03** by Common S.A., equipped with Bi3-EG12-RY1/S1000<sup>(1)</sup> sensors

(Hans Turck GmbH, Certificate No.: KEMA 02ATEX1152X marking

$\text{Ex II 1G Ex ia IICT4...T6}$  or  $\text{Ex II 2G Ex ia IICT4...T6}$ )

(1) – required linear characteristics of the emitter power circuit.

Permissible supply parameters of the above mentioned transmitters from intrinsically safe circuits, maximum inductance and internal capacitance of the transmitters are as follows:

- **CHF1-03**  $U_i = 20 \text{ V}$ ,  $I_i = 60 \text{ mA}$ ,  $P_i = 200 \text{ mW}$ ,  $L_i = 350 \mu\text{H}$ ,  $C_i = 180 \text{ nF}$ .

The application conditions and supply parameters are marked on the transmitter housing.

The transmitters are equipped with 4-pin plugs „Tuchel” C091 31W004 100 2. The connecting cables should be provided with sockets „Tuchel” C091 31D004 100 2. The transmitter is connected to pins „3” and „4” of the plug. The sketch of the transmitter connection with the measurement circuit is show in Fig. 5.

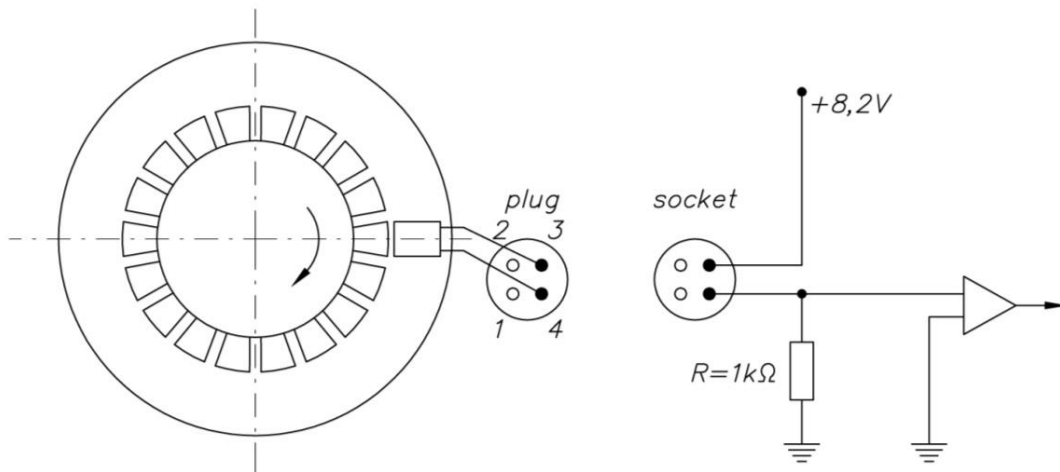

Fig.5. HF pulse transmitter connection sketch

The number of HF pulses per one cubic meter of gas is determined individually for each gas meter and is indicated in the nameplate (Fig. 8) located on top of the index head.

**A dash placed in the nameplate instead of number of pulses, or lack of description, indicates that an appropriate pulse transmitter has not been installed**

**NOTE!**

Intrinsic safety parameters are electrical parameters designated during analysis of construction of intrinsically safe device. Their values are determined for the most unfavorable state of work or damage to the device. The values of these parameters are limited to the levels that are safe for the given explosive mixture. They should not be treated as technical parameters of the device's operation.

The conditions for compliance of the intrinsic safety parameters of connected devices are presented in the table below.

Conformity conditions for intrinsic safety parameters				
Connected external device		Condition	Gas meter	
Output voltage	<b>U<sub>o</sub></b>	≤	<b>U<sub>i</sub></b>	Input voltage
Output current	<b>I<sub>o</sub></b>	≤	<b>I<sub>i</sub></b>	Input current
Output power	<b>P<sub>o</sub></b>	≤	<b>P<sub>i</sub></b>	Input power
Maximum external capacity	<b>C<sub>o</sub></b>	$C_o \geq C_i + C_k$	<b>C<sub>i</sub></b>	Internal capacity
Maximum external inductance	<b>L<sub>o</sub></b>	$L_o \geq L_i + L_k$	<b>L<sub>i</sub></b>	Internal inductance

The distributed parameters of cables (Ck), (Lk) should be taken as:

- The least favorable parameters given by the cable manufacturer or
- Parameters measured in accordance to **EN 60079-14** or 200pF/m & 1μH/m or 30μH/Ω where the connection consists of 2 or 3 wires (with or without shield)

**Nominal operating parameters of the emitters:**

**reed contact emitter / Wiegand emitter**

**CLFK-03 / CLFK-04 / CLFW-01 / CLFW-02 / CLFW-04**

closed switch resistance	$R_z = 100\Omega \div 2\text{ k}\Omega$
open switch resistance	$R_o > 100\text{ M}\Omega$
max. switching frequency	$f_p = 2\text{ Hz}$

**inductive emitters**

**Si5-K09-Y1**

**Bi1-EG05-Y1**

Maximum switching frequency	$f_p = 2\text{ Hz}$	$f_p = 0.5\text{ kHz}$
Rated operating voltage	$U_n = 8,2\text{V}$	
Rated current of the non-activated sensor	$I \geq 2,1\text{mA}$	
Rated current of the energized sensor	$I \leq 1,2\text{mA}$	

Other rated operating parameters of the transmitters are in accordance with the requirements of PN-EN 60947-5-6: 2002.

When connecting transmitters to inputs of pulse receiving devices, the polarity of conductors should be maintained. Only LFK and AFK transmitters do not require polarization.

The HF output is especially useful in order to control the changes of the gas flow.

**Pressure measurement outputs.**

Pressure measurement output (pressure pulse tap) is located on the side of the main body (Fig. 2). The tap may be provided either with M12x1,5 thread (Fig. 6a) or NPT1/4 thread (Fig. 6b). The thread type is marked on the body. The pressure tap is used for connecting the pressure transmitters directly, or indirectly by means of a three-way valve.

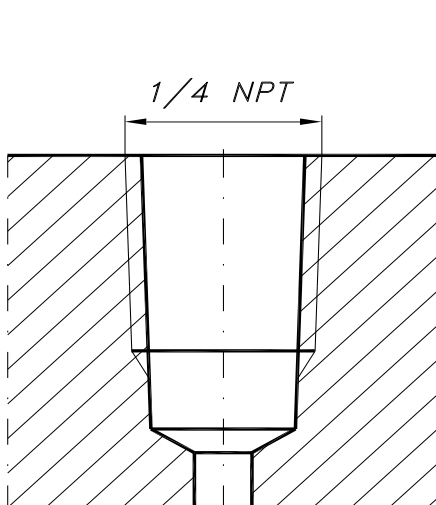

Fig. 6a. M12x1,5 pressure measurement tap.

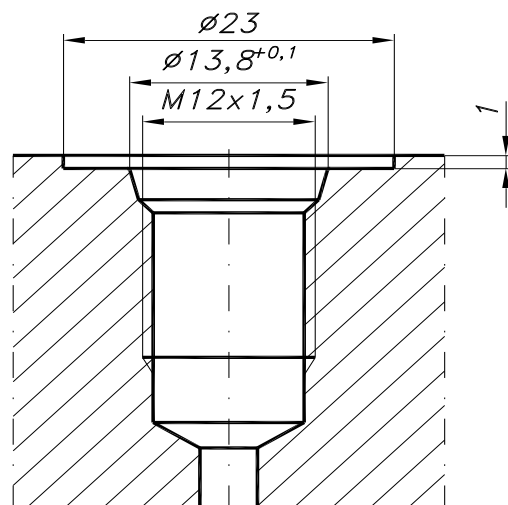

Fig. 6b. NPT 1/4 pressure measurement tap

### Temperature measurement outputs.

CPT-01 quantometers are equipped with temperature measurement outputs only when delivered as a special order version; temperature sockets are not available in standard versions.

Temperature measurement outputs are located on both sides of the main body of the meter (Fig. 2). Standard thermowells, with M12x1.5 female thread sockets (different threads on order), are to be filled with silicone oil and fitted with one of two types of electric thermometers (Fig. 7a and 7b) or plugged (Fig. 7c). Temperature sockets, when thermowells are not installed, must be plugged.

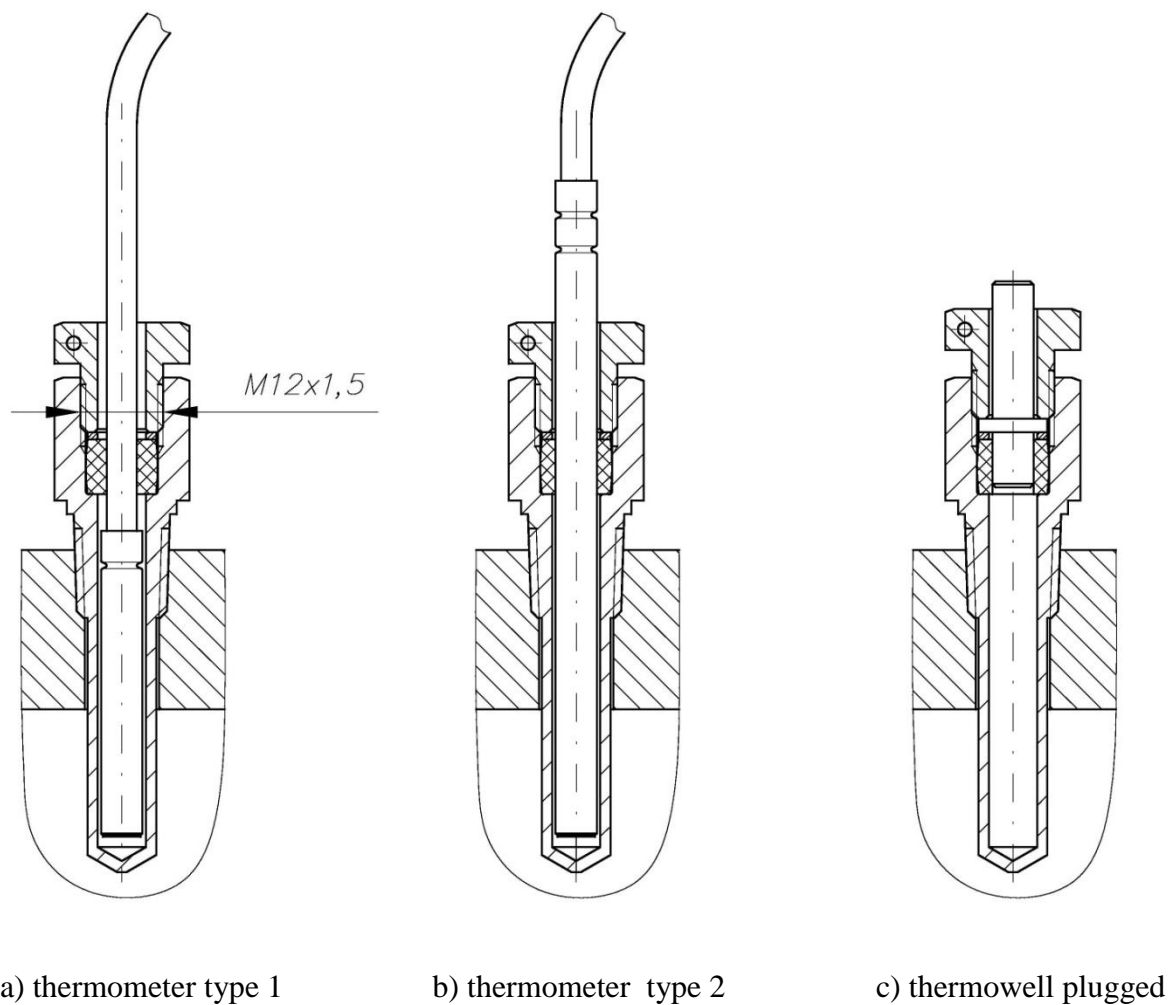

Fig. 7 Temperature outputs with thermowells

#### IV. MARKING AND CALIBRATION OF THE QUANTOMETERS

Basic specification of the gas meter, serial number and production year is shown in the nameplates (Fig. 8 and Fig. 9). The plates are fixed to the index housing by means of screws. Two first digits of the serial number indicate the gas meter size code, according to Table 2. Information marks (Fig. 10) are placed on the main body or external devices.

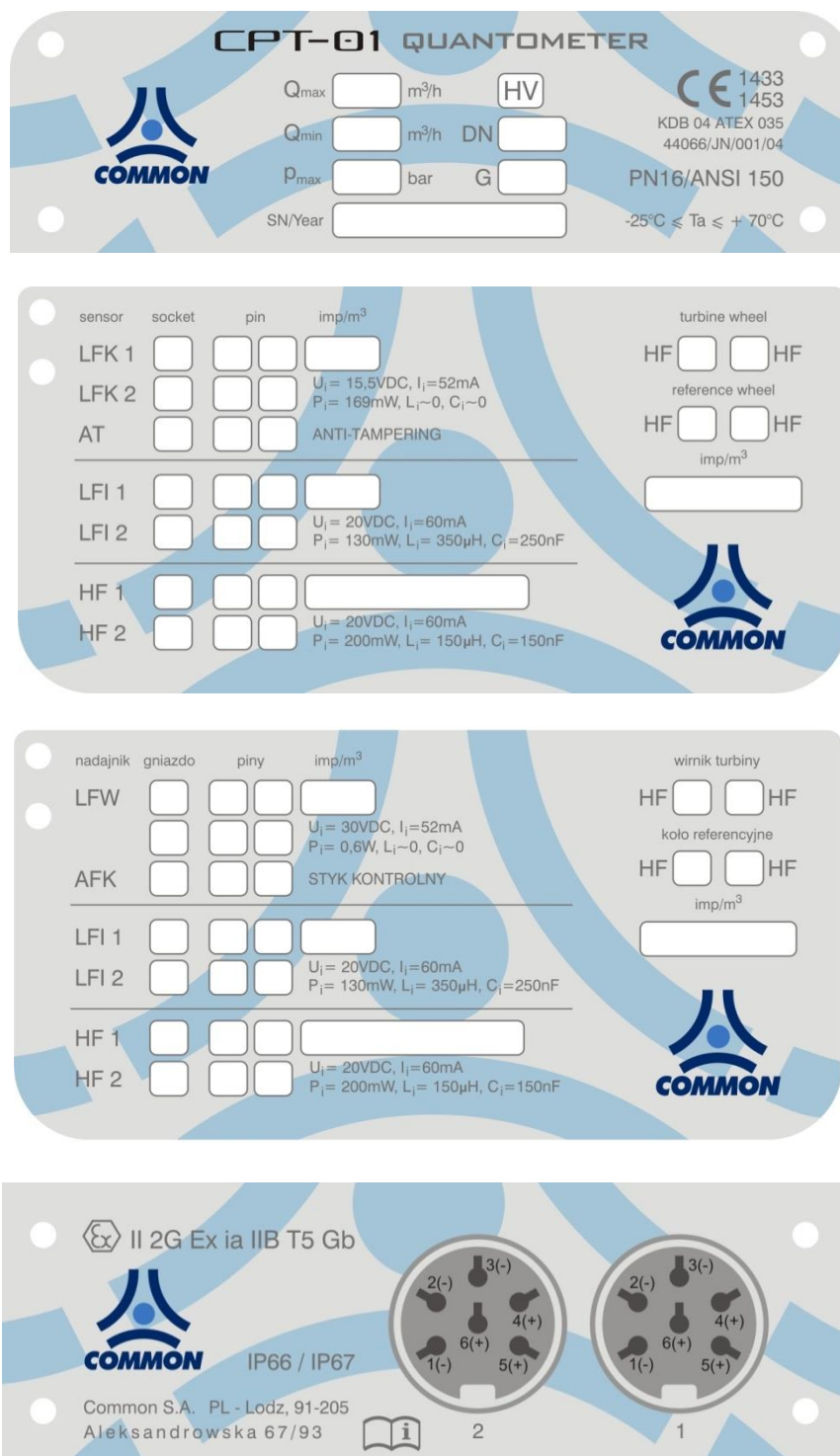

Fig. 8. Standard version nameplates

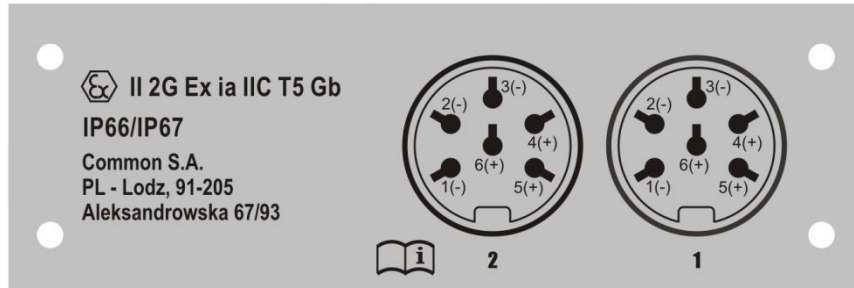
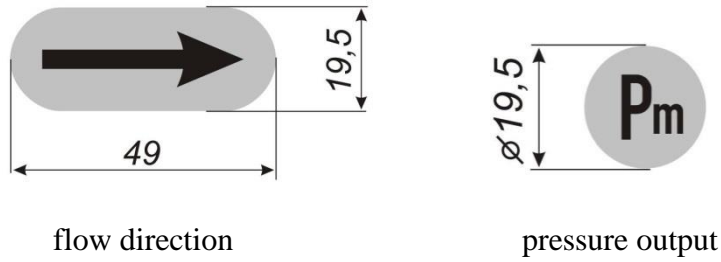
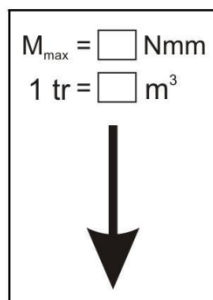

Fig. 9. Special version nameplate



example of oil type



mechanical output



HF emitter type plate

Fig.10. Information marks

Each quantometer is calibrated in the manufacturer’s laboratory or other recognized laboratory. The calibration certificate may be delivered on customer’s request. Connections that are not being dismantled during the quantometer installation are protected with seals of the manufacturer or of a recognized laboratory (P1, P2, P3, P4, P6 and P8 Fig. 11a, c).



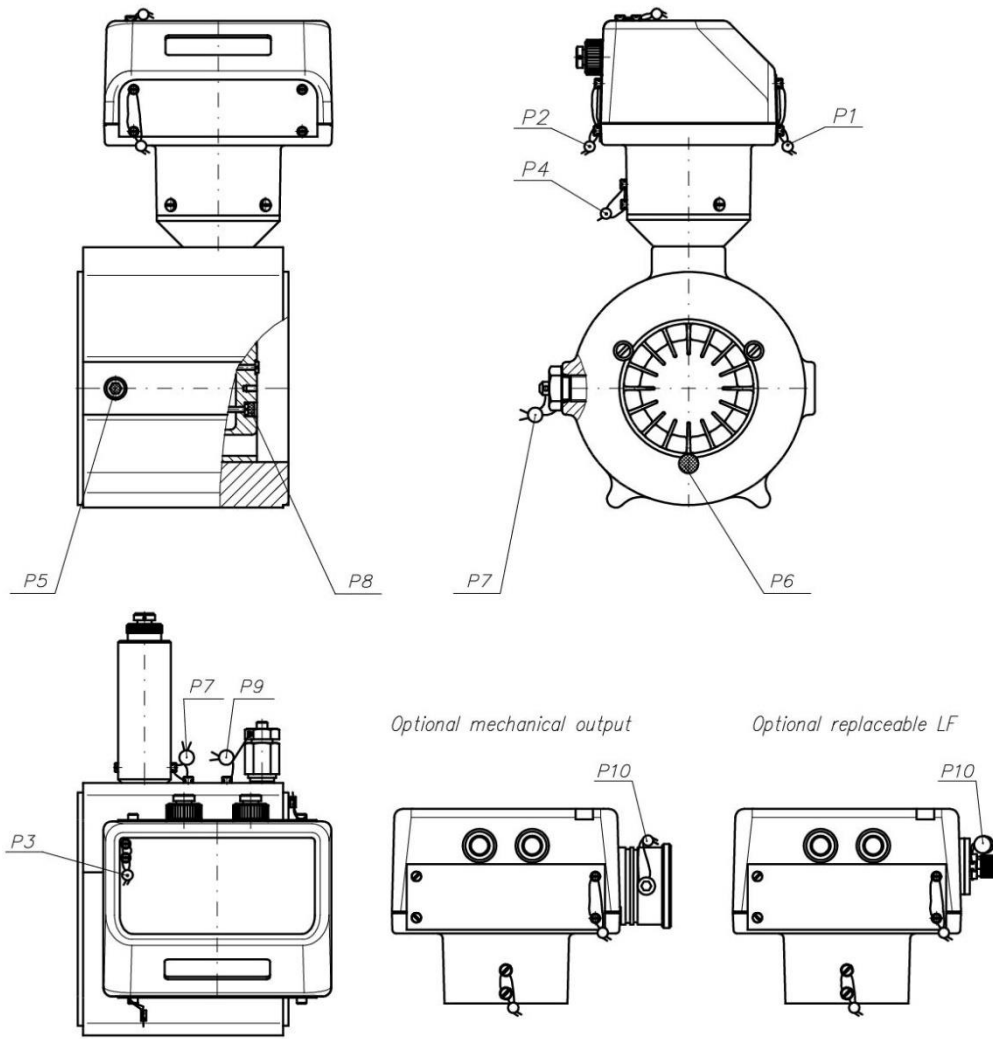

Fig.11a. Location of seals on the CPT-01 Quantometers (old version)

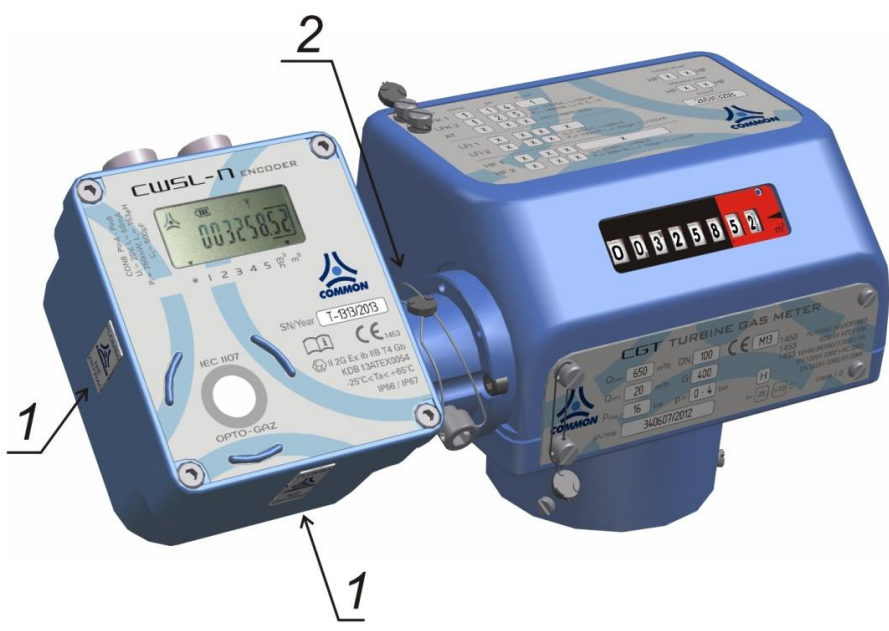

Fig.11b. Location of additional seals on the CPT-01 with Encoder CWSL-N.

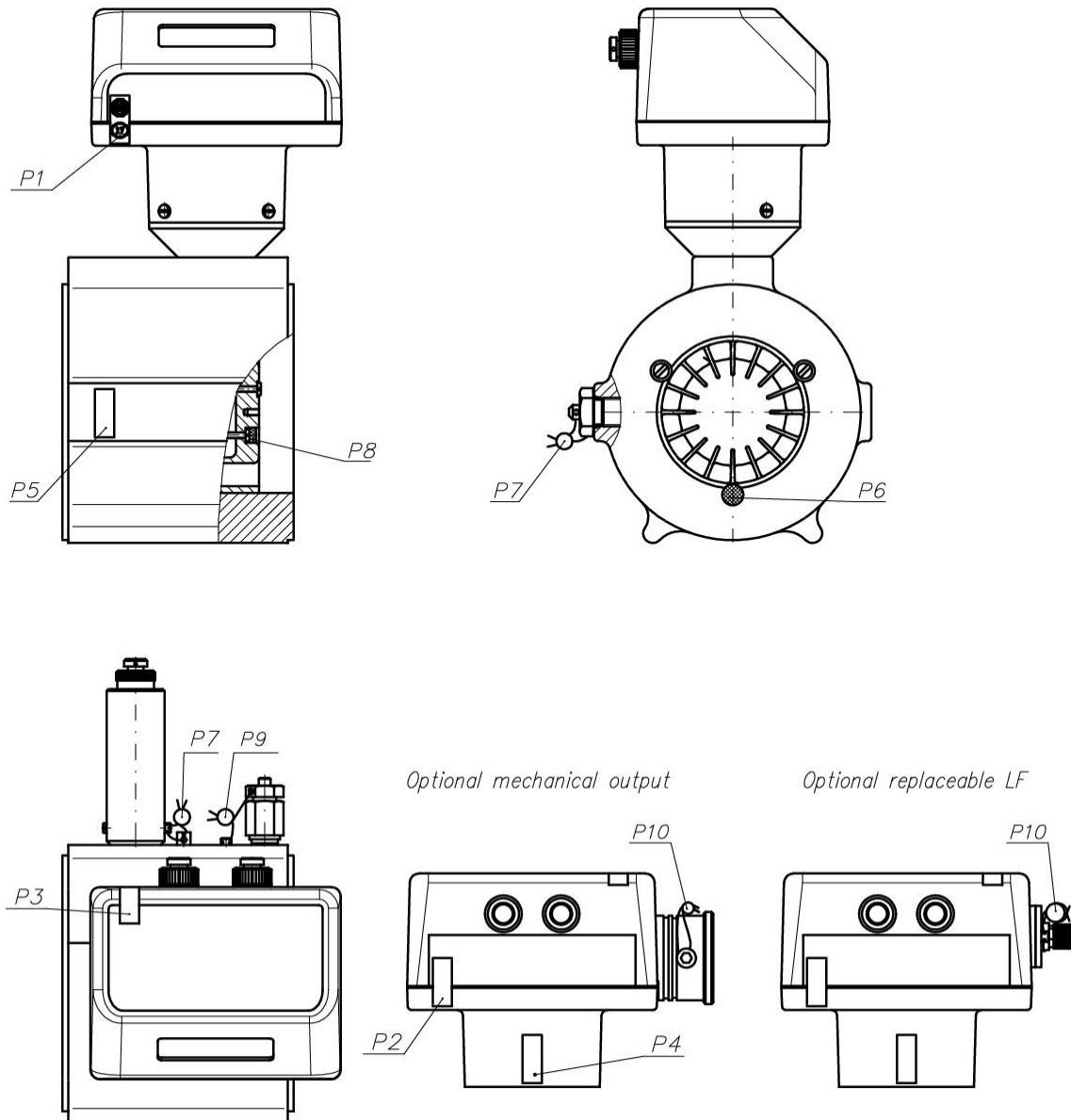

Fig.11c. Location of seals on the CPT-01 Quantometers (new version)

Protective seals installed on the pressure sensor tapping (P5), on the temperature outputs (P9), on the HF transmitter (P7) and optional on the mechanical output (P10) are marked by the manufacturer, by the gas supplier or by the authorized installer. Additionally the protective seals should be installed on unused electric signal output caps, and, if necessary, on the provided three way valve.

**If the seals are damaged the guarantee may become invalid.**

## ***V. PACKAGING, TRANSPORTATION AND STORAGE***

The gas meter is delivered in a factory packaging which secures the instrument during transportation and storage. The packaging consists of a reinforced cardboard box and corrugated cardboard inserts. Appropriate information on the package content, as well as limitations on loading / unloading, is placed on the package. The boxes are provided with special openings which facilitate to handle the meters. Quantometers returned for repairs or recalibration, should be delivered to the factory in their original packaging or other that provide at least the same protection during transportation as the original ones.

Each CPT-01 Quantometer manufactured by COMMON S.A. is provided with the following accessories:

- 6-pin plug “Tuchel” C091 31H006 100 2 that may be used for connecting a volume corrector’s or a data logger’s low frequency electric output (if the volume corrector or data logger is not delivered as a set with the quantometer);
- 4-pin socket “Tuchel” C091 31D004 100 2, if the gas meter is equipped with HF transmitter installed in the body;
- Operating Manual
- Turbine quantometers in special version, adapted for external lubrication, are additionally equipped with the oil tank and syringe.

**THE TURBINE QUANTOMETER IS A PRECISE MEASURING INSTRUMENT AND SHOULD BE HANDLED WITH UTMOST CARE**

Following recommendations should be observed during transportation and storage:

1. The quantometers should be protected against falls, shocks, or strong vibrations during transportation (e.g. due to handling on improper trolleys).
2. Lifting the quantometers by means of the index housing is not allowed.
3. Factory installed covers or seals on the meter openings should be removed just before the meter installation.
4. When storing the quantometers should be protected against direct atmospheric influence, and against humidity.
5. Take care not to damage the protective seals installed on the quantometer.

*Packing of Quantometers CPT-01 DN32 and DN25  
with screw connections*

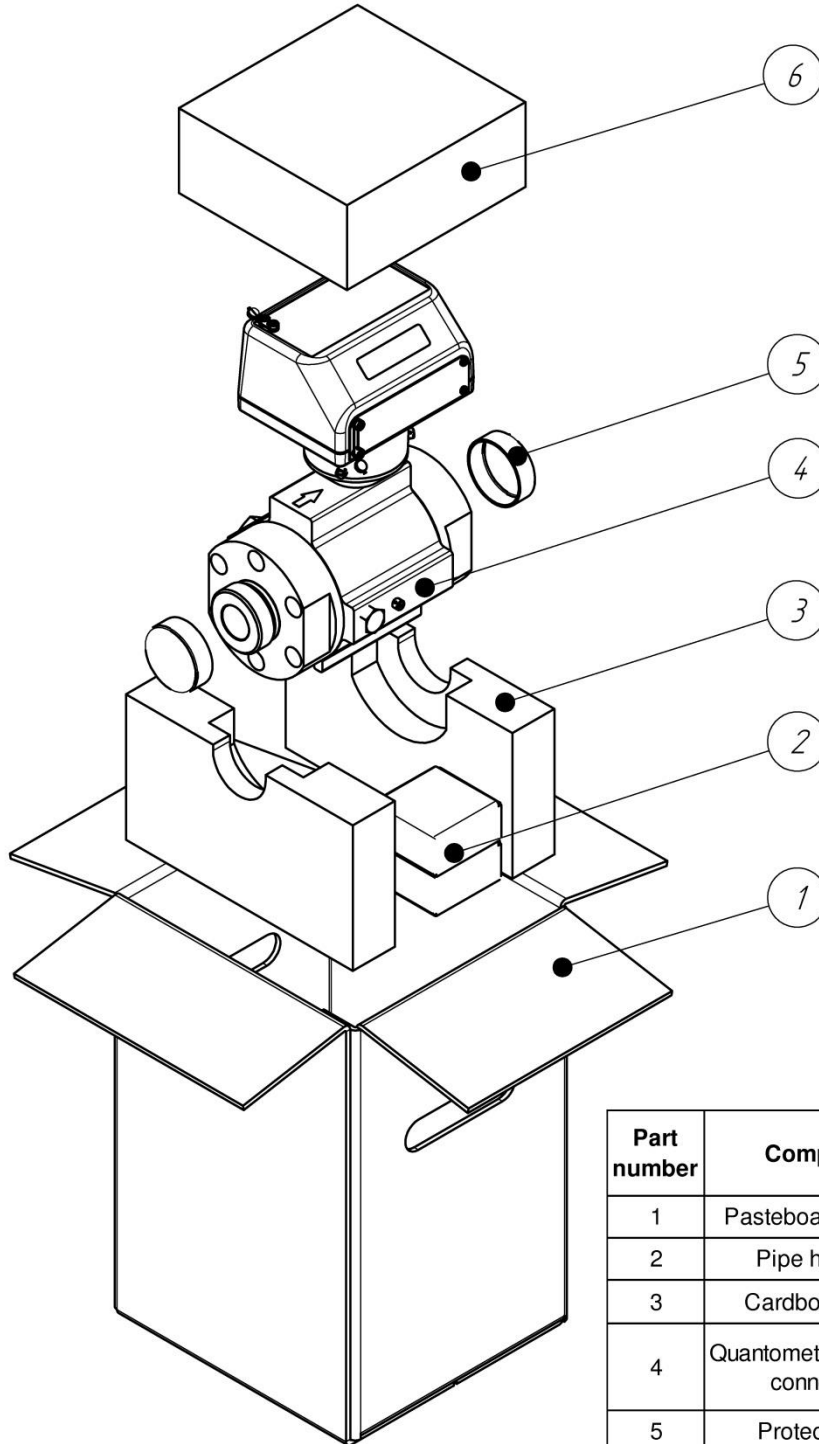

Part number	Component	Quantity
1	Pasteboard box CPT	1
2	Pipe half-union	2
3	Cardboard insert	2
4	Quantometer with screw connections	1
5	Protective cap	2
6	Index insert	1

*Packing of Quantometers CPT-01 DN50 and DN40  
with screw connections*

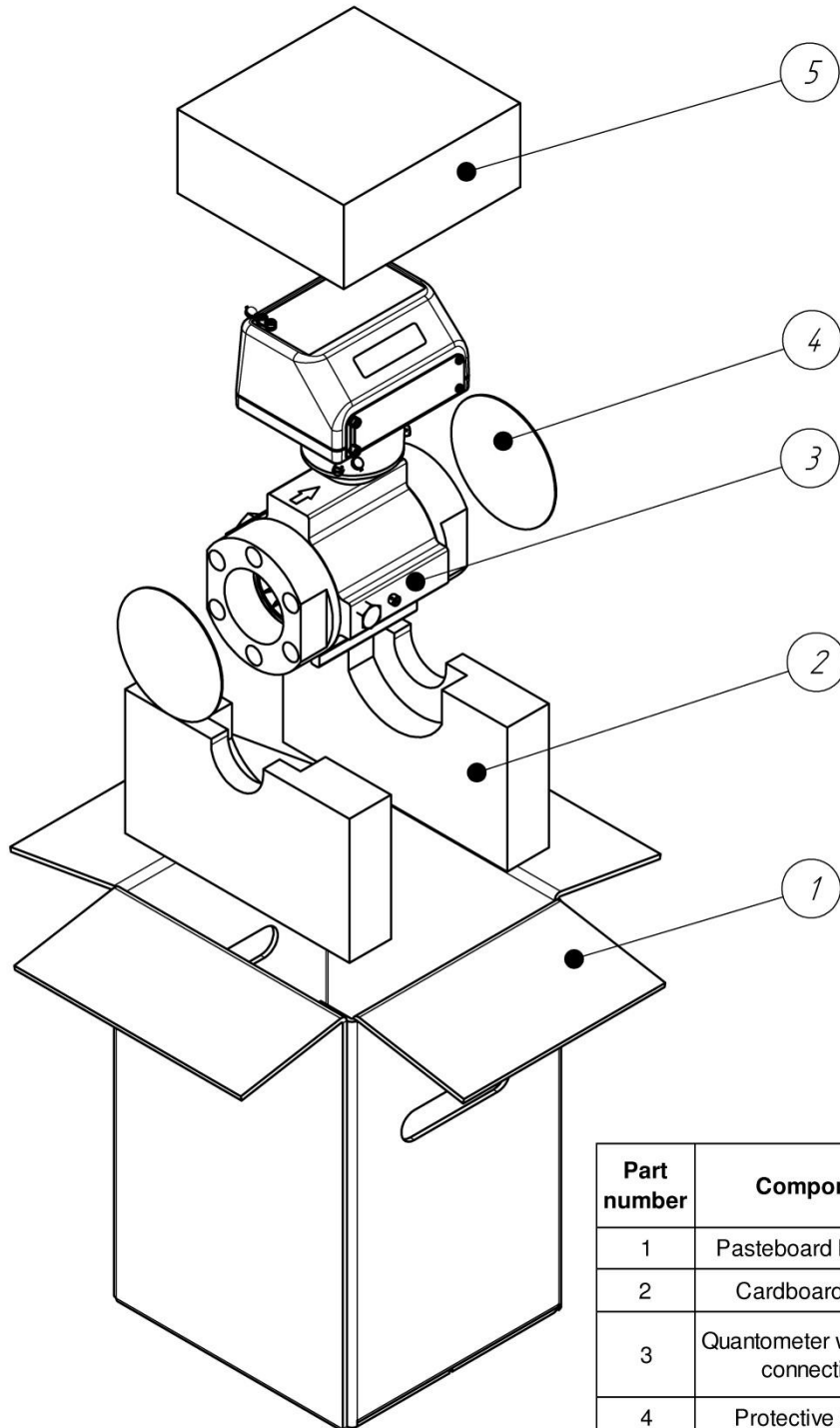

Part number	Component	Quantity
1	Pasteboard box CPT	1
2	Cardboard insert	2
3	Quantometer with screw connections	1
4	Protective sticker	2
5	Index insert	1

## Packing of Quantometers CPT-01: DN50, DN65, DN80, DN100

*Don't use to the CPT DN100*

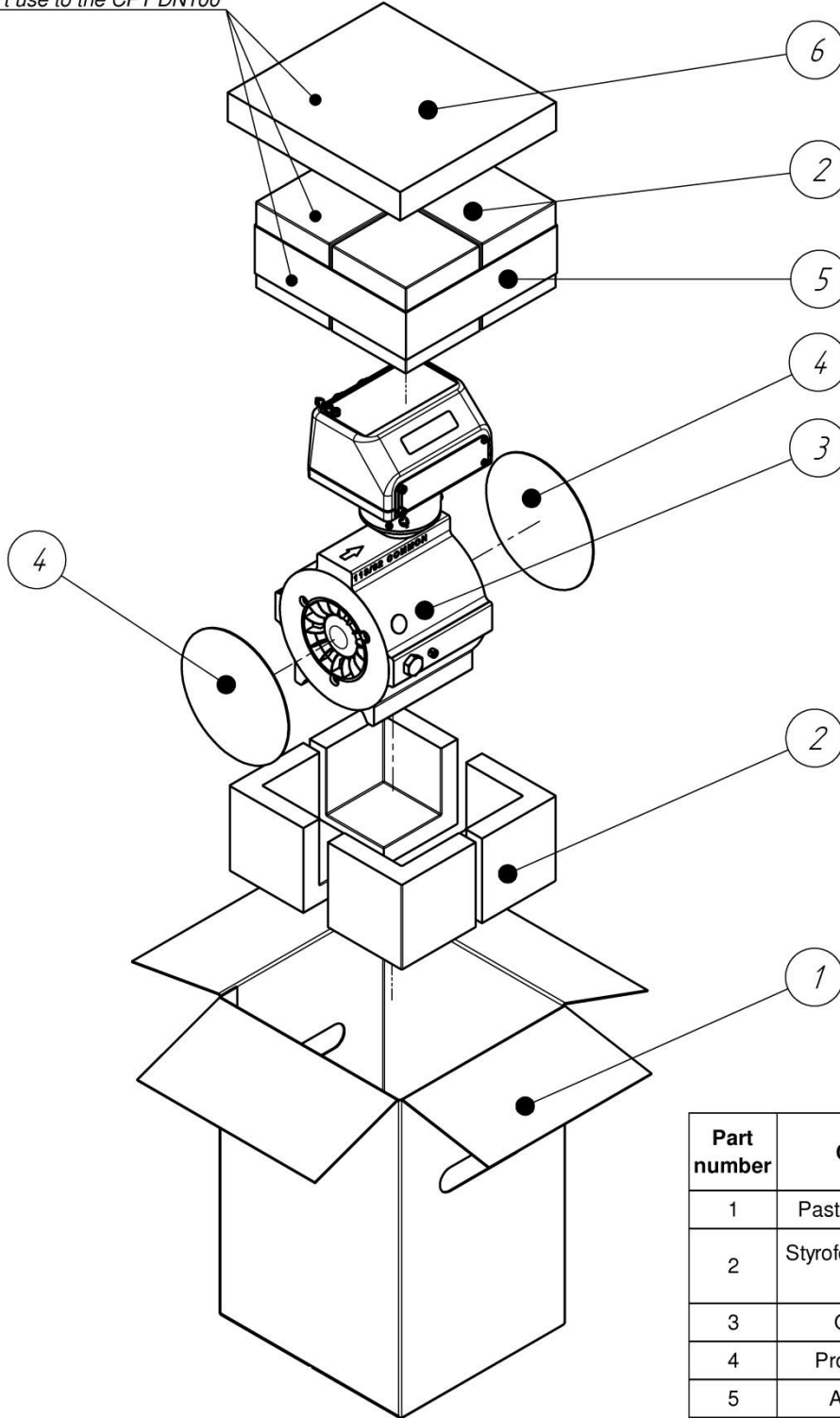

Part number	Component	Quantity
1	Pasteboard box CPT	1
2	Styrofoam or cardboard inserts	8
3	Quantometer	1
4	Protective sticker	2
5	Adhesive tape	1
6	Styrofoam or cardboard insert (use only to the DN50)	1

## Packing of Quantometers CPT-01 DN150

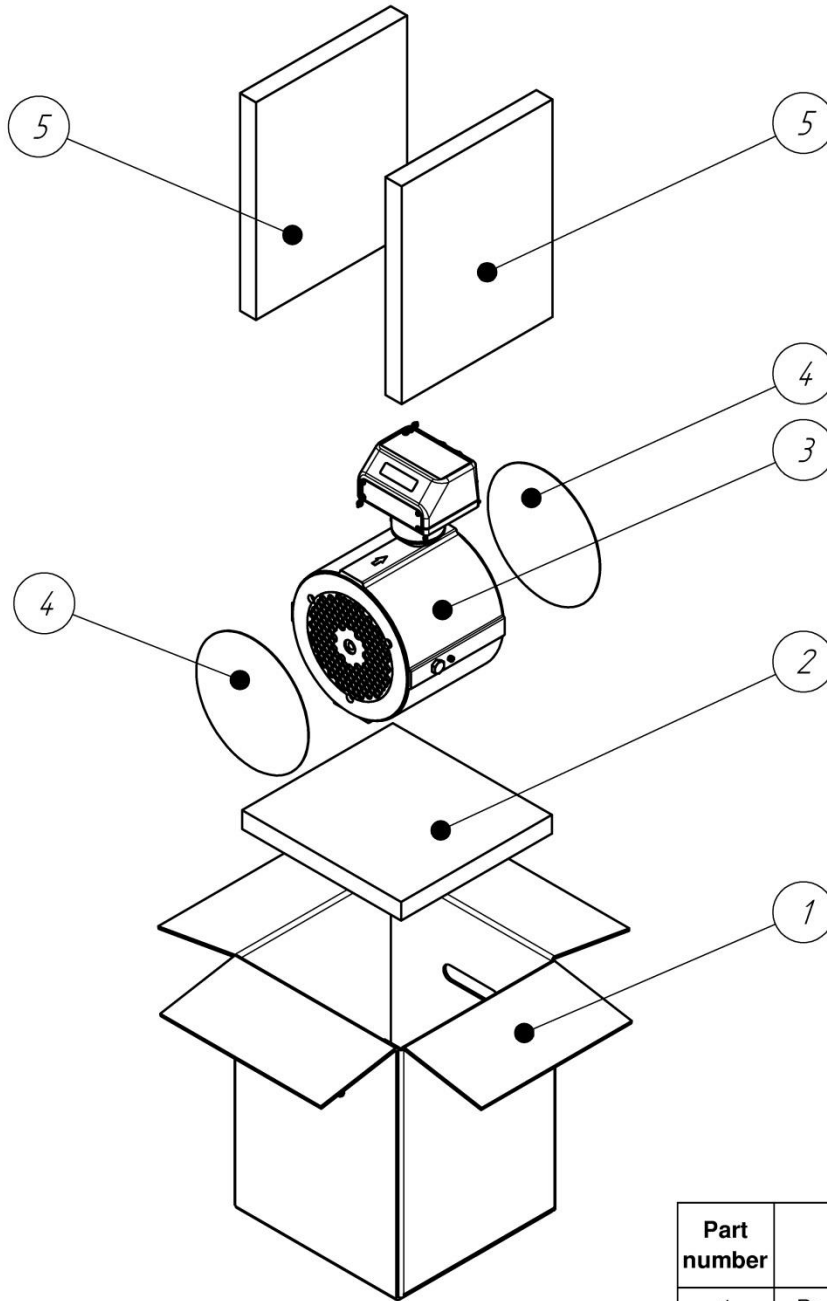

**Attention:**  
Wrap the device in bubble wrap.

Part number	Component	Quantity
1	Pasteboard box CPT	1
2	Styrofoam or cardboard insert	1
3	Quantometer	1
4	Protective sticker	2
5	Styrofoam or cardboard insert	2

## Packing of Quantometers CPT-01 DN200

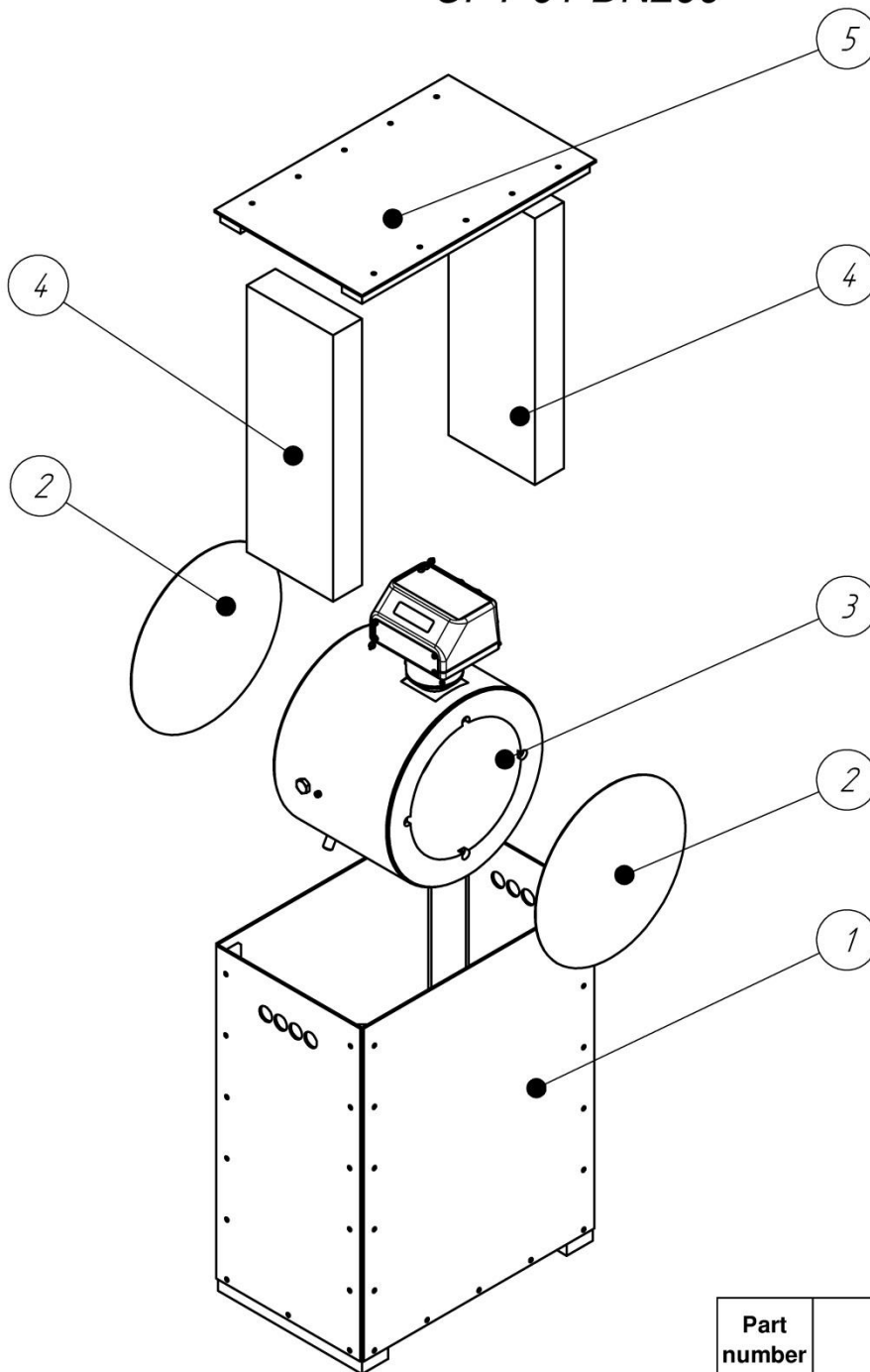

**Attention:**  
*Wrap the device in bubble wrap.*

Part number	Component	Quantity
1	CPT box	1
2	Protective sticker	2
3	Quantometer	1
4	Styrofoam or cardboard insert	2
5	The lid of box	2



## VI. INSTALLATION AND START-UP

Prior to the installation of the quantometer check whether it has been selected properly, in accordance with the operating parameters of the system. In particular, attention should be paid to the following information contained in the nameplate:

- maximum operating pressure [MPa], marked  $p_{\max}$
- maximum real flow [ $\text{m}^3/\text{h}$ ], marked  $Q_{\max}$

**It is permitted to operate the quantometer with flow bigger by 25% than the designed maximum flow within maximum 30 minutes.**

The quantometers should not be installed in the lowest position of the installation as it is possible that condensate and other impurities may collect there. CPT-01 can be used both indoors in stabilized temperature conditions and outdoors (open locations).

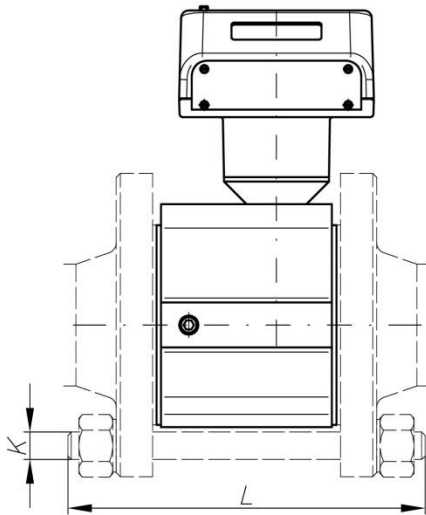

[1] Standard version  
DN50 ÷ DN200

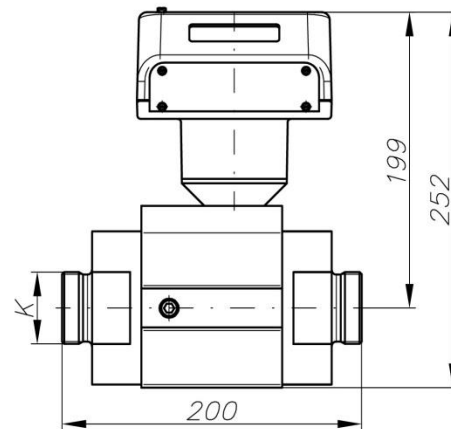

[2] Standard version DN50  
with external thread

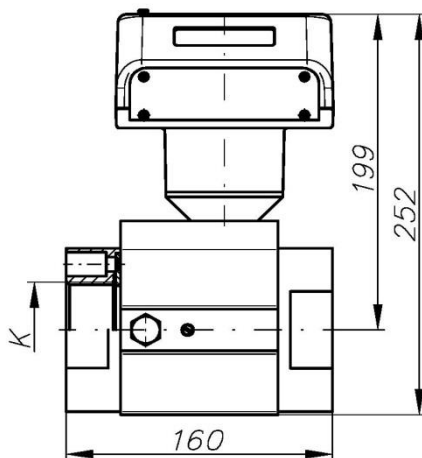

[3] Standard version DN50  
with internal thread

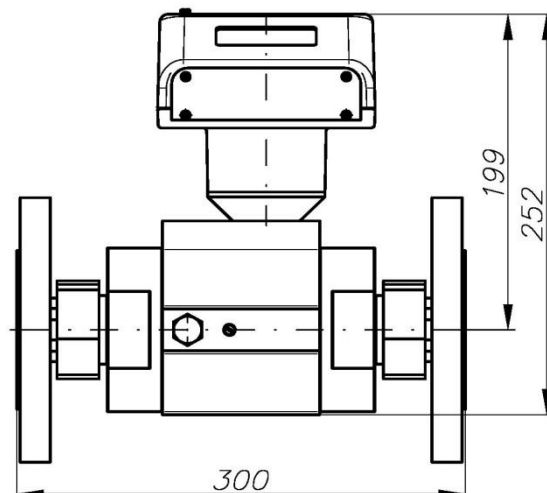

[4] Standard version DN50  
with flanges

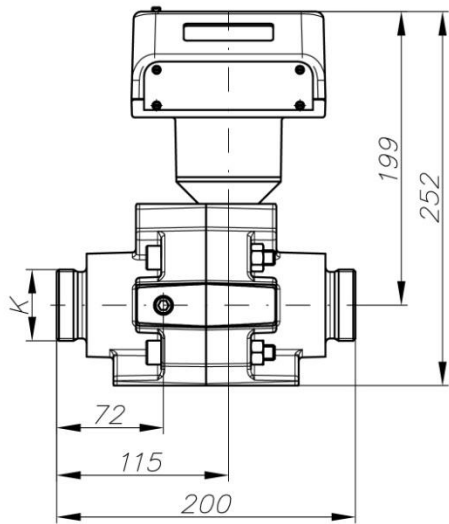

[5] New version DN50  
with external thread

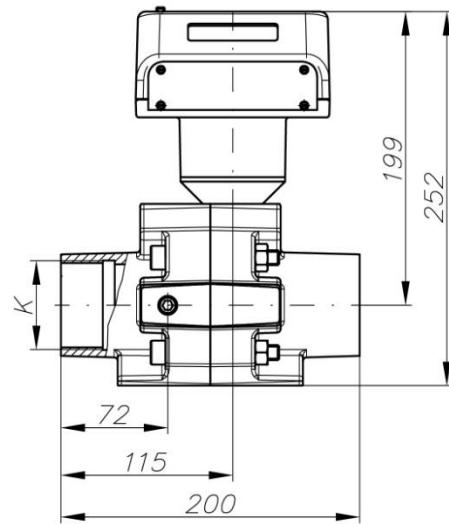

[6] New version DN50  
with internal thread

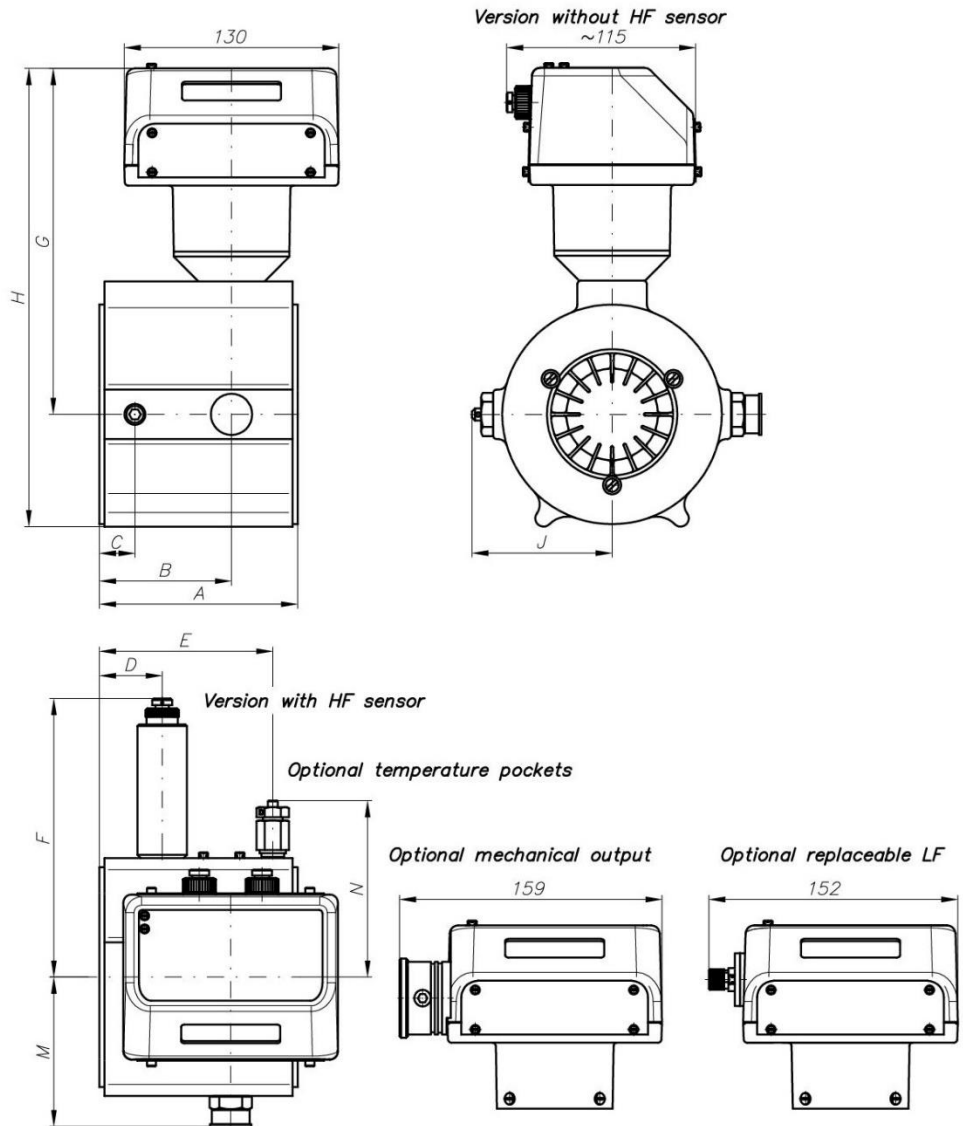

Fig.12. Installation dimensions quantometers series CPT-01

The quantometer should be installed in piping of the appropriate nominal diameter. Proper alignment of the meter and pipe flanges should be assured. It is recommended to install appropriate upstream and downstream pipe sections.

Turbine quantometer in standard version (Fig. 12 [1]) has a flat face in order to be installed in the pipework between PN16 and PN20 (ANSI150) flanges. In special version the CPT-01 turbine quantometer can be equipped with threaded connections or flanges (Fig. 12):

- [2] external thread connection 1" or 1¼" (DN 25) and 1¼" (DN 32),
- [3] internal thread connection G1½" (DN 40) and G2" (DN 50),
- [4] flanges (DN 25, DN 32, DN 40, DN 50).

Maximum allowed bending moment for CPT-01 with threaded connection :

- for DN 25 Mg=250 Nm,                      - for DN 32 Mg=350 Nm,
- for DN 40 Mg=390 Nm,                      - for DN 50 Mg=440 Nm,

The quantometers are to be fixed in the piping by means of stud bolts, according to the following standards: EN ISO 898-1, EN ISO 3506-1:2009, ISO 888. For standard flanges flat gaskets may be used (acc. to EN 1514-1:1997 or EN 12560-1:2001).

When designing the installation follow the dimensions given in Table 4 and Fig. 12.

**Table 4. Basic dimensions and weight of the CPT-01 quantometers**

DN	A	B	C	D	E	F	G	H	J	K	L	Mass
mm	mm	mm	mm	mm	mm	mm	mm	mm	mm		mm	kg
25	100	-	18	32	158	74	199	252	-	1", 1¼"	-	4,6
32	100	-	18	32	158	74	199	252	-	1¼"	-	4,6
40	100	-	18	32	158	74	199	252	-	G1½"	-	4,4
50	100	-	18	32	158	74	199	252	-	G2"	-	4,4
40 <sup>(*)</sup>	100	65	18	32	158	74	199	252	-	4xM16	260	4,4
50	100	65	18	32	158	74	199	252	-	4xM16	200	3,6
65	120	80	21	38	170	86	211	278	90	8xM16	220	5,1
80	120	80	21	38	170	86	211	278	90	8xM16	220	5,3
100	150	100	29	53	185	100	225	305	105	8xM16	250	7,4
150	180	127	50	76	210	125	243	351	130	8xM16	300	11,6
200	200	146	56	83	225	140	272	407	145	12xM20	320	48

(\*) – equipped with flat face adapters (Fig. 12 [3]) for installation in the pipework between flanges DN40 PN16.

Impurities contained in gas and in the piping may cause damages to the measuring assembly and decrease the measurement accuracy. Therefore it is recommended to install the 10 µm filter upstream the quantometer (especially in case of heavy polluted gases). Besides, prior to the installation, it is recommended to clean the upstream piping, and to provide a Top Hat Filter (cone sieve) before the meter. The filter may be removed after 1 – 2 months of operation. If the filter is not removed than it is necessary to maintain it regularly and control the pressure drop. If the filter is clogged it may get damaged by the gas pressure, and the debris may seriously damage the quantometer .

**THE MANUFACTURER IS NOT LIABLE FOR ANY DAMAGES TO THE QUANTOMETER DUE TO IMPROPER FILTRATION OF THE FLOWING GAS**

The user of the meter should pay special attention to some risk related to gas flow changes. If for a longer time, after commissioning, the flow in the piping was relatively low the impurities (e.g. welding spatters) remain upstream the gas meter. When the flow increases the flowing gas may sweep away these impurities and in consequence the meter may get damaged. Due to that the Top Hat Filters are very practical solution when the new installation is reaching its designed output. Nevertheless, the user should protect the gas meter against mechanical damages.

Prior to the installation of the gas meter it is necessary to check whether it is oriented properly, i.e. whether the arrow located on the body indicates the proper flow direction.

### **START-UP**

In order to start up the quantometer properly the following recommendations should be observed (typical installation with the by-pass, Fig.13):

1. The quantometer is installed with the valves 1, 2, 5 closed, and the by-pass valve 4 open. The vent valve 3 remains open after venting the installation.
2. Having tightened the bolts remove the air from the installation by opening the valve 5. This must be done in accordance with appropriate local regulations. The valve 3 remains open.
3. Having removed the air from the installation close valve 3 and pressurize the installation. Observe that the pressure increase is no greater than  $30 \pm 10$  kPa/s.
4. When the index does not indicate any flow (it means that the pressure is equal in the installation), close the valve 5.
5. First, open the valve 1 and next the valve 2.
6. Having fully opened the valve 2, the by-pass valve 4 is to be closed.

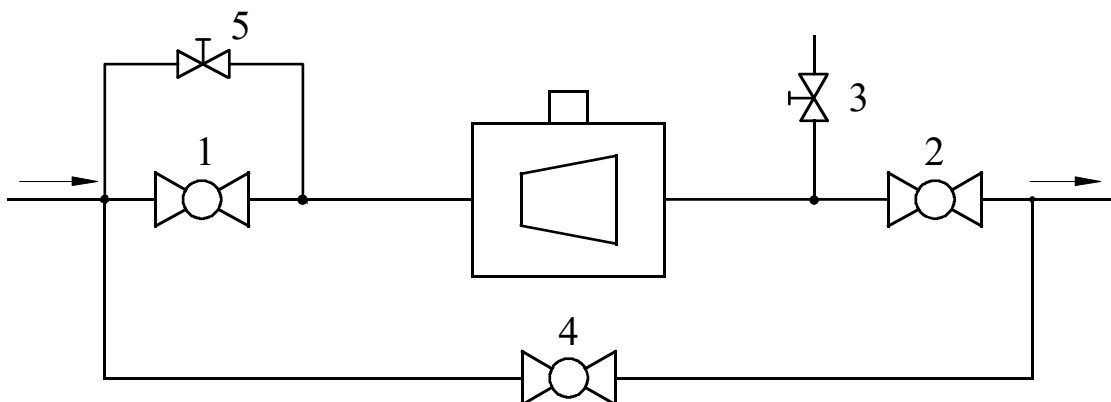

Fig. 13. Diagram of the measuring system with the by-pass valve

When removing the gas meter from the installation, proceed opposite, i.e.:

1. First, open the by-pass valve 4,
2. Consecutively, close the valve 2, and next the valve 1

3. Release the pressure from the measurement installation by means of the vent valve 3; pressure decrease should be not more than  $30 \pm 10$  kPa/s.

In other cases the procedure should be similar, i.e. open and close the gas flow through the gas meter very slowly. **Sudden increase of flow caused by abrupt opening of valves may bring about damages to the measurement turbine due to large pressure difference upstream and downstream the meter.**

If during the usage of the gas meter overloads may occur (i.e.  $Q_{\max}$  is overcome by more than 25 %), then it is recommended to install orifices. The orifice should be installed downstream the gas meter at the distance of 5 to 10 nominal pipe diameters. The orifice plate size is determined individually, depending on the nominal pipe diameter, flow, pressure and temperature of the gas. On request COMMON S.A. may provide appropriate orifices.

After installation of the quantometer check whether indications of the index are proper. Each drum of the index should rotate freely, and after one full turn it should move the next left drum by  $1/10^{\text{th}}$  of its rotation.

**Unused electric output sockets must be closed with factory supplied caps and seals in order to protect them against corrosion and pollution.**

## VII. MAINTENANCE, FAULTS, REPAIRS

CPT-01 turbine quantometers in standard version are maintenance free devices, because the bearings used in them have a supply of lubricant. As an option, CPT-01 turbine quantometers (from DN65 to DN200) may be adapted for external lubrication (see chapter VII AUXILIARY EQUIPMENT). During maintenance of turbine quantometers adapted for external lubrication please follow the recommendations listed below.

For gases listed in Table 1, lubrication should be carried out after each portion of gas  $V_g$  [m<sup>3</sup>] specified in Table 5, but not less frequently than once a month. For refinery gas, sewage gas and sludge digestion gas, the interval between lubrication should be 1 week.

*Table 5. Recommended lubrication conditions*

G	V <sub>g</sub> [m <sup>3</sup> ]	V <sub>o</sub> [cm <sup>3</sup> ]	G	V <sub>g</sub> [m <sup>3</sup> ]	V <sub>o</sub> [cm <sup>3</sup> ]
G65	65.000	1	G400	400.000	3
G100	100.000	2	G650	650.000	4
G160	160.000	2	G1000	1.000.000	4
G250	250.000	3	G1600	1.600.000	6

For lubrication it is recommended to use LUBRINA oil or VR09 oil, which are distributed by COMMON S.A.. For turbine quantometers DN65 and DN80 the recommended oil is VR09 or LUBRINA L12 with a viscosity of about 12 mm<sup>2</sup>/s (cSt) at the temperature of 20°C. For lubrication of bigger turbine quantometers the recommended oil is LUBRINA L23 with a viscosity of about 23 mm<sup>2</sup>/s. For gases listed in Table 1, also oil SHELL TELLUS T15 is accepted.

**Turbine quantometers used for gases other than those listed in Table 1, should be lubricated with other oil. In those cases, the type of oil should be consulted with the quantometer's manufacturer.**

Dust and other contaminants from the surface of the meter can be removed with a cloth dampened with soapy water. Do not use cleaning solvents or other chemicals.

If during operation of the meter any abnormality occur (e.g. uneven run, stoppage of index, higher noise level, rattling) the quantometer should be removed from the installation and sent for repair.

**REPAIRS OF THE QUANTOMETERS MAY BE PERFORMED ONLY BY THE MANUFACTURER OR BY AUTHORISED PERSONNEL. IS NOT ALLOWED TO PERFORM REPAIRS BY THE USER!**

After repairs when calibrations leaden seals were removed it is necessary to recalibrate the quantometer.

## VIII. AUXILIARY EQUIPMENT

### Lubrication kit for quantometers

Special version of CPT-01 turbine quantometers can be adapted for external lubrication. They are then fitted with the oil feed to bearings which is completed with a pressure check valve. Lubrication is carried out with the use of kit supplied with a quantometer:

- ✓ basic kit (for use up to 0,5 MPa gauge pressure) consist of oil tank and syringe,
- ✓ special kit (for use from 0,5 MPa up to 2 MPa) consist of oil tank and a special pump.

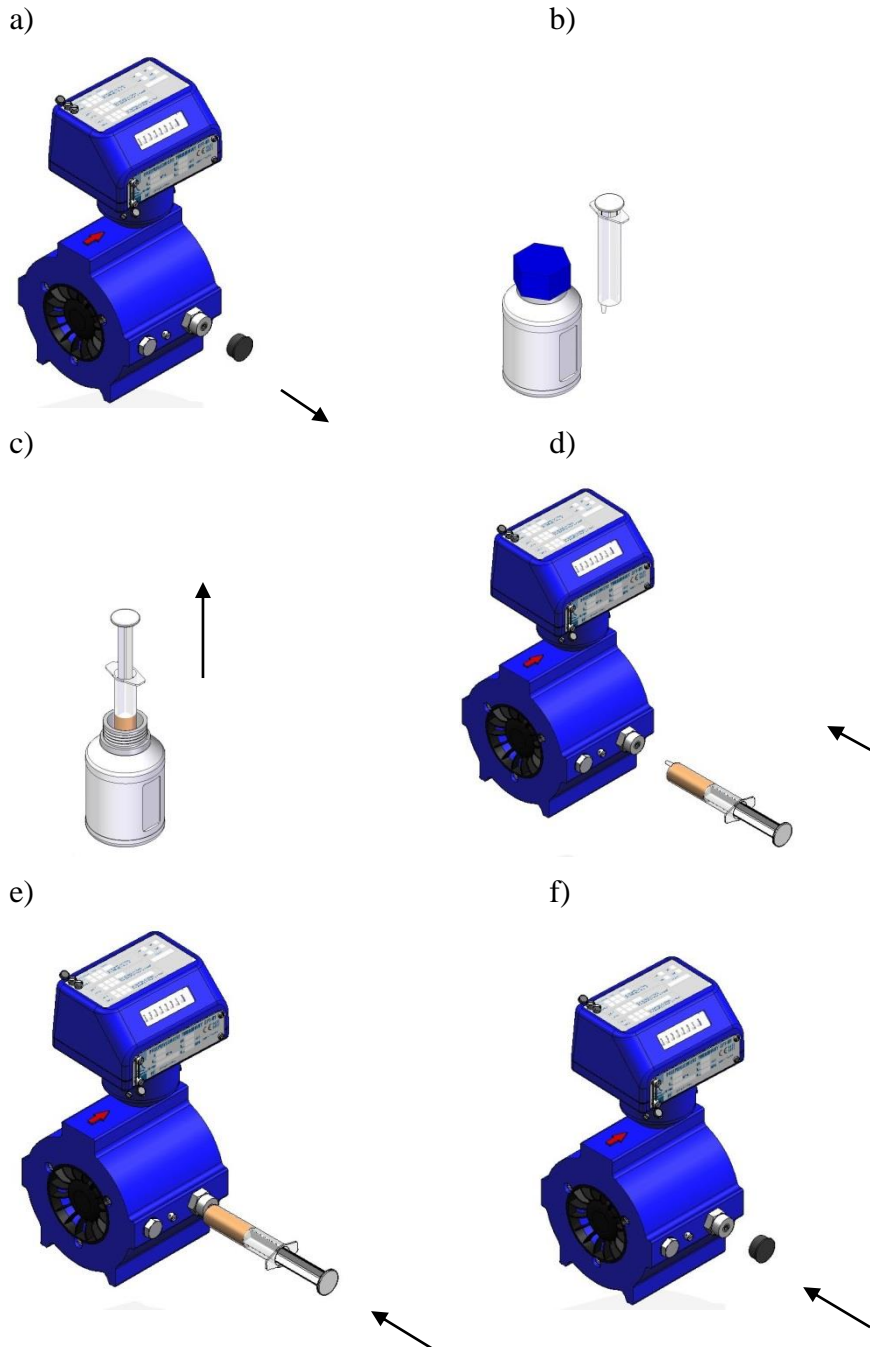

Fig. 14. Lubrication of CPT-01 quantometer.

Sequence during lubrication of turbine quantometer (Fig.14):

- a. Remove the cap protecting the valve from contamination,

- b. Set up the oil injection kit,
- c. Draw the appropriate amount of oil (see Table 4) into syringe or into special pump,
- d. Press the tip of the syringe or tip of the special pump into the hole of the valve,
- e. Slowly inject the measured amount of oil,
- f. Remove the tip of syringe or pump from the valve, insert the protective cap.

**Turbine quantometers can be lubricated with syringe only if the maximum pressure in the pipework is 0,5 MPa. If the pressure in the pipework is higher than 0,5 MPa, special pump should be used for oil injection.**

### LF Replaceable transmitters type CLFK-04 or CLFW-04

As the special execution the CPT-01 turbine quantometers can be equipped with index housing adapter for replaceable transmitters. CLFK-04 (reed contact) or CLFW-04 (Wiegand) transmitters (Fig. 15a) can be, in case of malfunction, replaced without the necessity of disassembling the index head and removing the initial verification seals or calibration seals. The permissible power supply parameters of the transmitters are specified on the name plates (Fig. 15b).

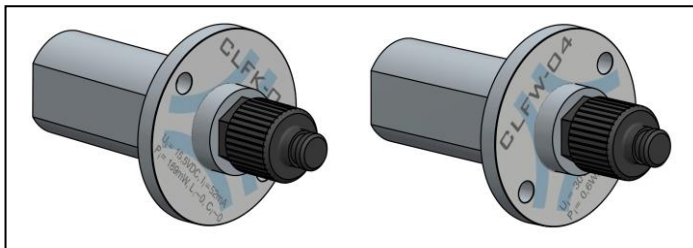

Fig. 15a Replaceable transmitters



Fig. 15b Transmitters name plates

The installation of transmitters is presented on Fig. 16 (a, b, c, d).

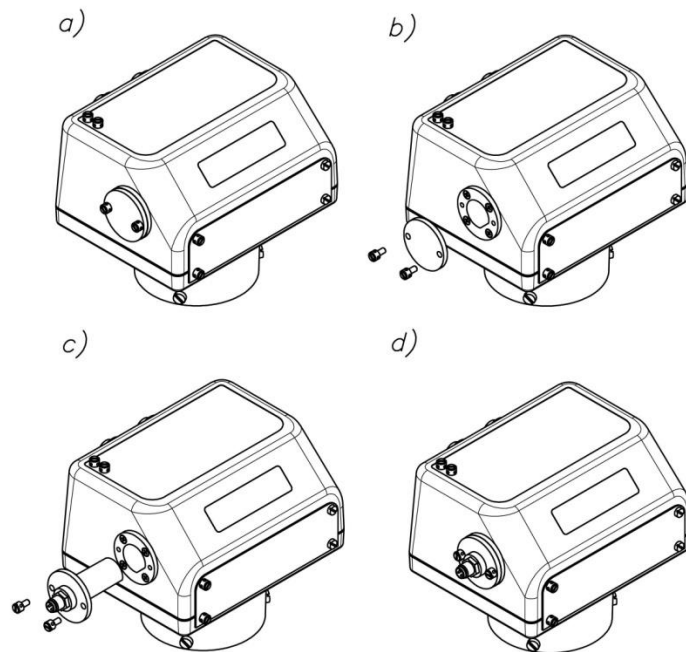

Fig. 16. The installation method of replaceable transmitters



**NOTE !**  
**CLFK-04 & CLFW-04 transmitters must not be used interchangeably.**  
**Index head is adapted to one type of transmitter only.**

**CWSL Encoder (option)**

CWSL Encoder can be connected to the optional mechanical output. There are 3 versions of (optional) Encoders available: CWSL-N, CWSL-A, CWSL-M (Fig. 23). Data sent from CWSL-N are equal to data on the index.

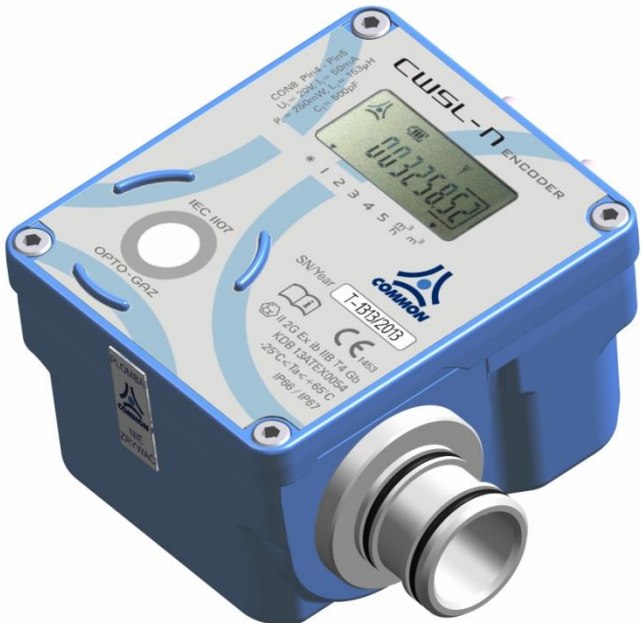

Fig. 17. CWSL Encoder adapted for connection with the index of CPT-01 quantometer.

**Connection of turbine quantometer with electronic volume converter**



Fig 18. Assembly of the CPT-01 Quantometer and the CMK-03 Volume Corrector (the volume corrector installed on the pipe)

In order to convert gas volume from operating into base conditions it is often required (or recommended) to use electronic volume converters. Common S.A. is also the manufacturer of such devices, e.g. volume correctors CMK-03 (VPTZ), CRS-03 (VTZ) and data loggers CRI-02. On requests COMMON S.A. may deliver these devices. Example of such installation is shown in Fig.18.

The volume corrector needs three input signals:

- flow (from the low frequency or high frequency pulse transmitter),
- pressure,
- temperature.

The pressure pulse is taken from the pressure tap. It is recommended to take the pressure pulses by means of the CKMT three way valve (Fig. 19) that enables to cut off the pressure sensor, and in consequence to disassemble and inspect this sensor. There is no need to stop the gas flow through the quantometer. The three way valve handle may be provided with a seal in order to protect it against unauthorized handling. The temperature signal is taken from a sensor installed in a temperature well downstream the quantometer (see Fig. 18).



Fig. 19. CKMT three way valve

**It should be kept in mind that all connections of additional equipment to the quantometer cause that the installation seals get damaged. Therefore such works may be performed by the representative of the gas supplier or by authorized installer. Unused electric output sockets must be closed by means of factory caps in order to protect them against corrosion and dirt.**

	<p><b>After expiration of the life cycle period, the gas meter should under no circumstances be discarded into municipal waste containers. The Waste Act of 27 April 2001 imposes an obligation for selective collection of metallic waste. Gas meters should be best returned to the manufacturer who would recycle them in an appropriate practice. If unable to do so, the user is obliged to deliver the gas meter to an appropriate recycling point.</b></p>
	<p><b>Gas meter packaging should never be discarded into municipal waste containers. The packaging has been appropriately labelled; pursuant to the Act of 11 May 2001 on packaging and packaging waste, the user is obliged to submit the packaging for an appropriate recycling process.</b></p>

Notice:

Technical specification and construction may change due to improvements. This publication serves as general information only, and all specifications are subject to confirmation by COMMON S.A.