

Technical User Manual



Cartridge Gas Filter GS Serie up to DN150

Main Features



Cartridge Gas Filters GS Serie According to 2014/68/EU Directive, EN 13445 standard.

Type GS and cellular gas filters are designed for retaining gas impurities, such as dust, rust and other solid particles, in gas-carrying lines at a defined location. They are mainly used in gas pressure regulating and measuring stations, power plant and upstream of equipment, the function of which would be impaired by contaminants. The filters are suitable for gases in accordance with DVGW Code of Practice G 260 / G 262 and neutral non-corrosive gases. (Other gases on request). According to 2014/68/EU directive.

- High filtration efficiency
- Large particle chamber
- High flow capability
- Outdoor version as standard
- Wide range of accessories
- Replaceable cartridge structure
- Eco-friendly cartridge
- Easy maintenance

Technical Features

Maximum allowable pressure –PS	25 bar
Allowable temperature –TS ⁽¹⁾	-20 °C to +60 °C
Inlet gas temperature	-20 °C to +60 °C
Nominal size –DN	DN25 DN32 DN40 DN50 DN65 DN80 DN100 DN125 DN150 It is possible to produce filters with different inlet and outlet diameters to order.
Connections ⁽²⁾	PN16, PN25 according to ISO 7005 Class 150 RF according to ASME B16.5 and
Filtration efficiency ⁽³⁾	Standard 99.9% of particle size > 2 µm
Limit for soiled filter insert	Δpmax = 500 mbar
Explosion protection	Mechanical components of filter do not contain a potential ignition source, thus do not fall in limits of ATEX 95 (94/9/EG). (Used electronic accessories comply with ATEX-demands.)

⁽¹⁾ Low temperature version -40°C: available on request

⁽²⁾ On request for other connection class

⁽³⁾ On request cartridge 5µm and 10µm

Materials

Body ⁽¹⁾	DN25 – DN150 EN-GJS 500-7
Cartridge ⁽²⁾	Polyester
Filter basket ⁽³⁾	Steel perforated plate, galvanised
Seals	NBR

⁽¹⁾ on request A 216 WCB available

⁽²⁾ On request paper

⁽³⁾ On request stainless steel

Gas Filter, GS Serie

**Desing,
 Operational Diagram**

Main purpose; is to clean the gas by keeping the solid particles in the gas

Gas velocity entering into the chamber of filter body is reduced, big solid particles falls into the stock chamber, the gas advancing with small particles encounters the cartridge. in the cartridge, the gas filtration are starting again and the solid particle is kept .

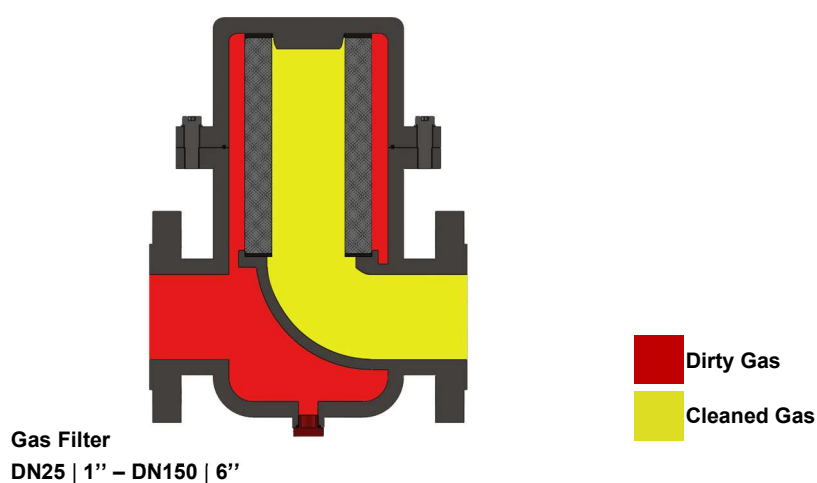

Configurations

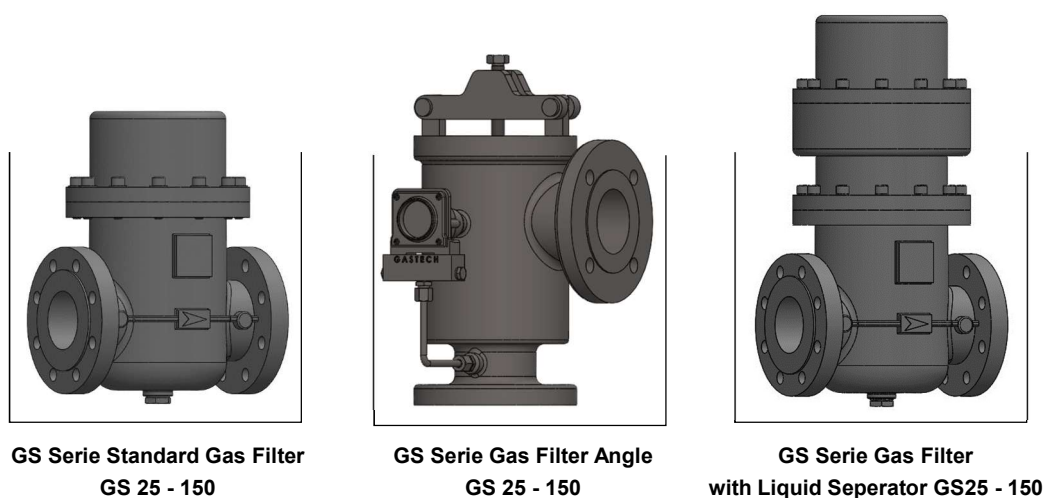

Gas Filter, GS Serie

Change & revision history

Date	Page	Reason	Statement

INDEX

Main Features, Technical Features, Materials1

Desing, Operational Diagram, Configurations2

Change & revision history.....3

Index.....4

Safety and Safe Use.....5

Summary of symbols, terms and units.....6

General Description and Operation7

Vent Lines for Safety (indoor or cabinet).....7

Environmental conditions, Pipe installation.....8

Capacity Tables.....9

Flow Calculations.....10

Dimensions and Weights11,12,13,14

Replacing the Cartridge.....15

Equipment List for Maintenance and Repair.....16

Personal Protective Equipmen List.....17

GS Serie 1" – 2" Replacing the Cartridge18

GS Serie 2 1/2" – 4 " Replacing the Cartridge19

GS Serie 5" – 6 " Replacing the Cartridge20

Safety and Safe Use

Warning Notes!

To safely use the equipment, observe the environmental conditions allowed and the data provided on the nameplate of the filter and any accessories.

To avoid injury to persons, damage to property or the environment, the following warning notes must be observed!

Any opening of the filter, replacement of parts or modifications to the original product is the user's responsibility and is done at his own risk.

Caution!

- All activities (mounting, installation and service work, etc.) must be carried out by qualified staff.
- Ensure that the relevant national safety regulations are complied with.
- Any gas filter that experience a fall or shock must not be put into operation, as this can adversely affect the safety functions even if they do not exhibit any external signs of damage.
- Unsuitable gases or gas components lead to a loss of the zero leakage function.
- It must not be possible for liquid to enter the gas filter, as this could have an adverse effect on the cartridge function.
- Gases with concentrations of >0.1% for H₂S and NH₃ are only permissible in connection with biogas version.
- Condensation is not permitted in the gas filter. If not observed, the filtration functions are no longer ensured.
- The GS serie gas filters are designed to withstand gas pressures up to 25 bar in standby mode or working. At a pressure of 25 bar, the GS serie gas filter remains safely closed or will safely work. If the maximum permissible operating pressure is exceeded, a pressure relief must be start
- The impulse pipe (pressure feedback) must be connected to the main outlet gas pipe, downstream from the gas pressure regulator observing a distance of at least 4 x the diameter of the main outlet pipe.
- The upstream and downstream pipes must be cleaned after being laid. Before commissioning, it is essential to ensure that extra no dirt particles have remained that could enter the gas filter.
- When the discharge valve on the filter is opened, be careful so that the vented gas does not cause ignition or explosion, do not vent in closed environments.
- The gas filter supplied by Gastech may only be repaired by Gastech Repair Centers.

Summary of symbols, terms and units

The following table summarizes the symbols and relevant descriptions and unit considered in this chapter and/or used in this document. The symbols are listed in alphabetic order.

Symbol	Terms	Unit
AC	Accuracy class	%
AG	Accuracy group	%
bpu	Inlet pressure range	bar
d	Relative density of natural gas at actual conditions	/
DN	Nominal size	/
DS	Differential strength	/
Δp	Differential pressure	bar
Δp_{min}	Minimum operating differential pressure	bar
IS	Integral strength	/
KG	Flow coefficient	See definition
LpA	Sound pressure level	EN 61672-1
MIPd	Downstream maximum incidental pressure	Bar
p	Component operating pressure	Bar
pb	Atmospheric pressure (absolute pressure)	bar abs
pd	Outlet pressure	Bar
pdmax	Maximum outlet pressure	Bar
pds	Set point	Bar
pf	Lock-up pressure	Bar
pmax	Maximum component operating pressure	Bar
pn	Reference absolute pressure for normal conditions	bar abs
PS	Maximum allowable pressure	Bar
PSD	Specific maximum allowable pressure	Bar
pu	Inlet pressure	Bar
pumax	Maximum inlet pressure	Bar
pumin	Minimum inlet pressure	Bar
SG	Lock-up pressure class	%
SZ	Class of lock-up pressure zone	Lock-up time
TS	Maximum/minimum allowable temperature	°C
V	Gas velocity	m/s
Wd	Set range	Bar
Wds	Specific set range	Bar

Gas Filter, GS Serie

General Description and Operation

Main purpose; is to clean the gas by keeping the solid particles in the gas

Gas velocity entering into the chamber of filter body is reduced, big solid particles falls into the stock chamber, the gas advancing with small particles encounters the cartridge. in the cartridge, the gas filtration are starting again and the solid particle is kept .

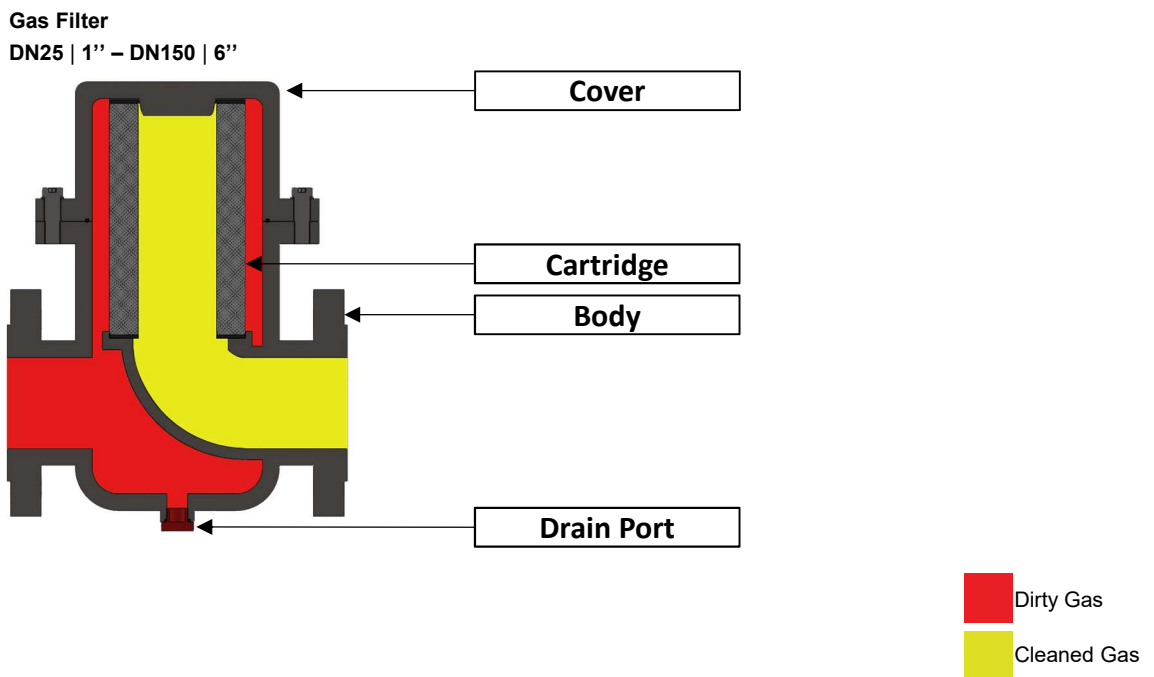

Vent Lines for Safety (indoor or cabinet)

The discharge outlets on the regulator must be transported to the outside with a pipe. In indoor use, if the vent lines are not carried outside, gas may leak into the environment when the regulator fails. Creates a risk of fire and explosion.

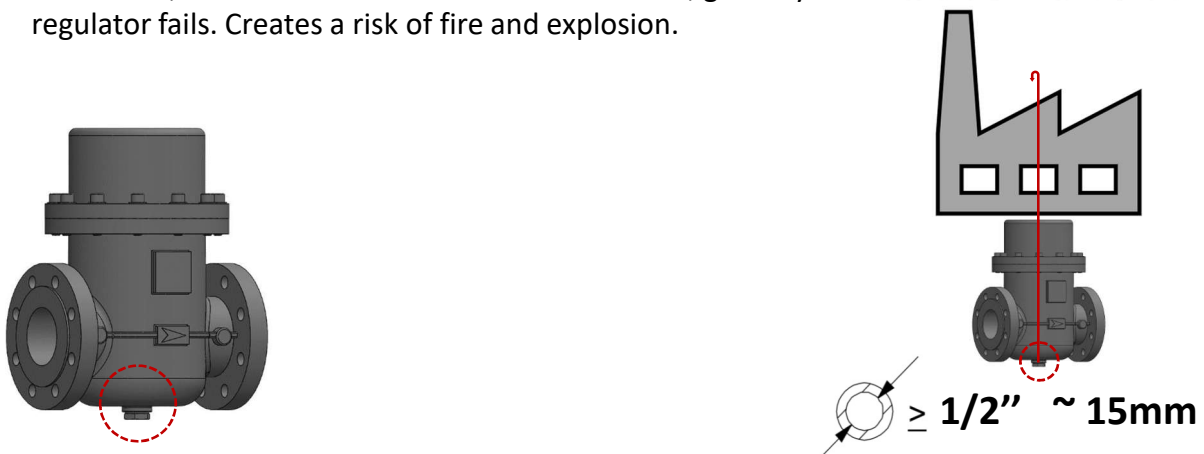

Make sure the gas is conveyed to a non-hazardous area with the vent line. Natural gas will rise due to lower density than air, GPL will go down due to greater density than air. The density of the gas used should be analyzed and accumulations should be prevented.

Gas Filter, GS Serie

Environmental conditions

Gastech guarantees the product under the following storage and transportation conditions. All functions of products that are stored unused for more than 3 years should be checked.

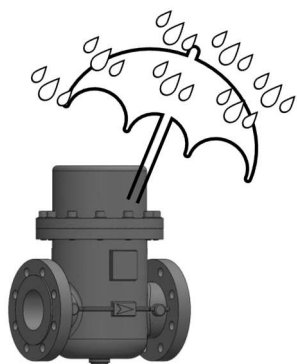

Storage IEC 60721-3-1

Climatic conditions	Class 1K3
Mechanical conditions	Class 1M2
Temperature range	-20...60 °C
Humidity	< 95 % r.h.

Transport IEC 60721-3-2

Climatic conditions	Class 2K2
Mechanical conditions	Class 2M2
Temperature range	-15...60 °C
Humidity	< 95 % r.h.

Pipe installation

Maximum tightening torque of flange bolts



	25 1"	40 1 1/2"	50 2"	65 2 1/2"	80 3"	100 4"	150 6"
PN 16/23	40	120	120	120	120	120	200
ANSI 150	40	120	120	120	120	200	300

1. Clean flanges
2. Insert gasket between flanges
3. Insert screws, washers and nuts, tighten by hand
4. Tighten screws crosswise in three steps as per the order indicated.

- Step 1: 25% M
- step 2: 50% M
- step 3: 100% M

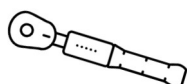

M = max. tightening torque

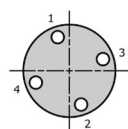

Circular 4-Bolt

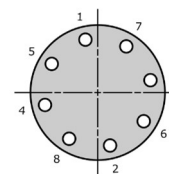

Circular 8-Bolt

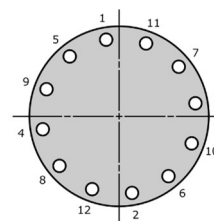

Circular 12-Bolt



use new sealing gaskets with every maintenance

Gas Filter, GS Serie

Capacity Tables

Diameter	Capacity										
	Gas Pressure (bar)										
	0,5	1	2	3	4	5	6	10	12	19	25
DN25 1"	54	71	107	142	177	213	248	389	460	708	920
DN32 1 1/4"	88	117	175	233	290	348	406	638	754	1160	1507
DN40 1 1/2"	137	182	273	363	454	544	635	997	1178	1812	2355
DN50 2"	214	285	426	568	709	851	992	1558	1841	2831	3680
DN65 2 1/2"	362	481	720	959	1199	1438	1677	2633	3111	4785	6219
DN80 3"	548	729	1091	1453	1815	2178	2540	3988	4713	7248	9421
DN100 4"	856	1139	1705	2271	2837	3403	3968	6232	7364	11325	14720
DN125 5"	1338	1780	2664	3548	4432	5316	6201	9737	11506	17695	23000
DN150 6"	1926	2563	3836	5109	6383	7656	8929	14022	16568	25481	33120

 These values are valid for natural gas of $\rho_n = 0.61 \text{ kg/m}^3$ and $t = 15^\circ\text{C}$. Δp 50mbar

Correction factor for non-natural gas applications

The flow rates are indicated for a 0.6 specific gravity gas. To determine the volumetric flow rate for gases other than natural gas, multiply or calculate the values in the capacity tables using the sizing equations with a correction factor. The table below lists correction factors for some common gases:

Gas Type	Density ratio to air	Conversion factor
Air	1.00	0.77
Butane	2.00	0.55
Propane	1.52	0,63
Propane+Air Mix	1.20	0,71
Hydrogen	0.07	2.94
Nitrogen	0.97	0.79
Carbondioxide	1.52	0.63

Use the following formula to calculate the correction factor for gases not listed above. In the formula, d is the specific gravity of the gas.

$$\text{Conversion factor} = \sqrt{\frac{0.6}{d}}$$

Stm3 /h /reference conditions 15 °C, 1 barg

Stm3 /h x 0.94795 = Nm3 /h Nm3 /h reference conditions 0 °C, 1 barg

Gas Filter, GS Serie

Flow Calculations

Can use the formula below to calculate the filter diameter

$$d = 18,8 \times \sqrt{\frac{Q}{P \times V}}$$

Acronyms

d	Filter diameter (mm)
Q	volumetric flow rate in (m ³ /h)
P	absolute inlet pressure in (bar)
V	Velocity (m/s)
18.8	Numerical constant

 the recommended gas velocity should be a maximum of 20 m/s

Select the diameter of the filter with higher than calculated value .
After finding the DN of the filter, check that gas speed on the seat does not exceed 20 m/sec, using the following formula:

$$V = 345.92 \times \frac{Q}{DN^2} \times \frac{1 - 0.002 \times P}{1 + P}$$

V	Velocity (m/s)
345.92	Numerical constant
Q	Flow rate under standard conditions (Stm ³ /h)
DN	Filter nominal diameter (mm)
P	absolute pressure in (bar)

Calculation of cartridge area of the filter

$$A = \frac{Q}{P \times V \times 3600}$$

A	Filtering area (m ²)
345.92	Numerical constant
Q	Flow rate under standard conditions (Stm ³ /h)
V	Velocity (m/s)
P	absolute pressure in (bar)

Cartridge area

Diemension	G 0.5	G 1	G 1.5	G 2	G 2.5	G 3	G 4	G 5	G 6
Surface m ²	0.060	0.125	0.230	0.470	0.725	0.95	1.45	2.3	4.2

Gas Filter, GS Serie

Dimensions and Weights

Standard Filters

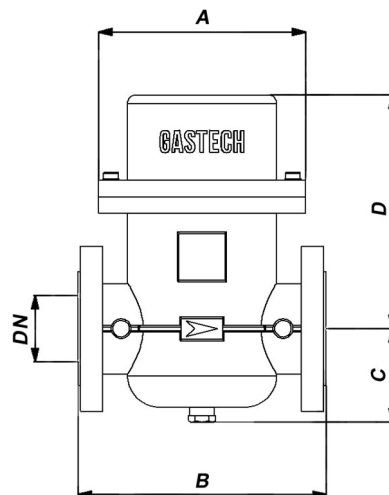

Diameter	A	B	C	D	Cartridge Surface	Cartridge Type	Internal Volume Lt	Wgt kg
DN25 1"	170	210	80	162	0,060	G 0.5	2,7	14
DN32 1 1/4"	170	210	80	162	0,060	G 0.5	2,7	16
DN40 1 1/2"	170	210	80	162	0,060	G 0.5	2,7	17
DN50 2"	170	210	80	162	0,060	G 0.5	2,7	18
DN65 2 1/2"	250	300	120	300	0,230	G 1.5	8,0	45
DN80 3"	250	300	120	300	0,230	G 1.5	8,0	47
DN100 4"	250	300	120	300	0,230	G 1.5	8,0	51
DN125 5"	280	450	205	320	0,725	G 2.5	15,0	130
DN150 6"	280	450	205	320	0,725	G 2.5	15,0	134

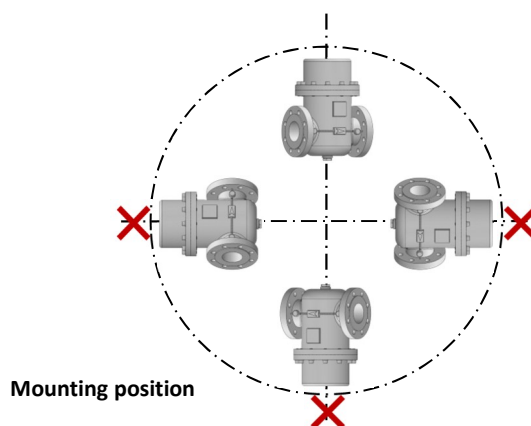

Gas Filter, GS Serie

Dimensions and Weights

High Flow Version

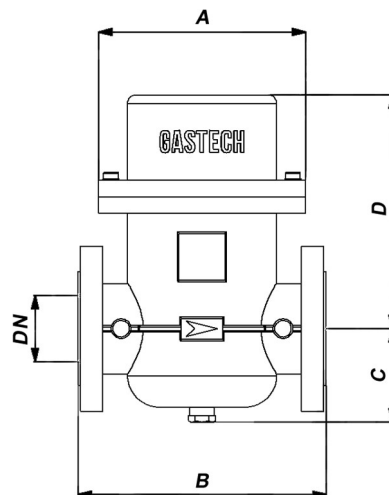

Diameter	A	B	C	D	Cartridge Surface	Cartridge Type	Internal Volume Lt	Wgt kg
DN25 1"	170	210	80	280	0,060	G 0.5 x 2	4,0	18
DN32 1 1/4"	170	210	80	280	0,060	G 0.5 x 2	4,0	20
DN40 1 1/2"	170	210	80	280	0,060	G 0.5 x 2	4,0	21
DN50 2"	170	210	80	280	0,060	G 0.5 x 2	4,0	22
DN65 2 1/2"	250	300	120	510	0,230	G 1.5 x 2	13,5	80
DN80 3"	250	300	120	510	0,230	G 1.5 x 2	13,5	82
DN100 4"	250	300	120	510	0,230	G 1.5 x 2	13,5	88
DN125 5"	280	450	205	605	0,725	G 2.5 x 2	22,0	165
DN150 6"	280	450	205	605	0,725	G 2.5 x 2	22,0	171

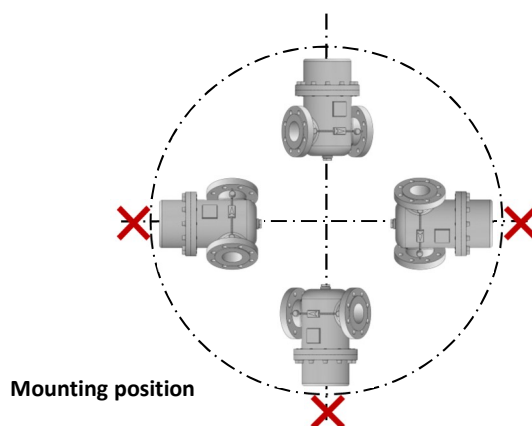

Gas Filter, GS Serie

Dimensions and Weights

Standard Version with Liquid Separated

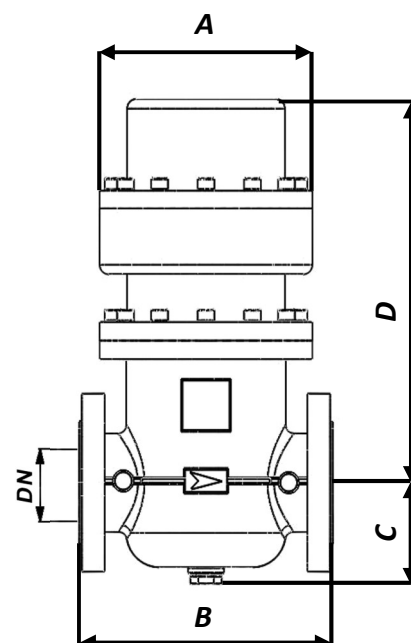

Diameter	A	B	C	D	Cartridge Surface	Cartridge Type	Internal Volume Lt	Wgt kg
DN25 1"	170	210	80	280	0,060	G 0.5 x 2	4,0	18
DN32 1 1/4"	170	210	80	280	0,060	G 0.5 x 2	4,0	20
DN40 1 1/2"	170	210	80	280	0,060	G 0.5 x 2	4,0	21
DN50 2"	170	210	80	280	0,060	G 0.5 x 2	4,0	22
DN65 2 1/2"	250	300	120	510	0,230	G 1.5 x 2	13,5	80
DN80 3"	250	300	120	510	0,230	G 1.5 x 2	13,5	82
DN100 4"	250	300	120	510	0,230	G 1.5 x 2	13,5	88
DN125 5"	280	450	205	605	0,725	G 2.5 x 2	22,0	165
DN150 6"	280	450	205	605	0,725	G 2.5 x 2	22,0	171

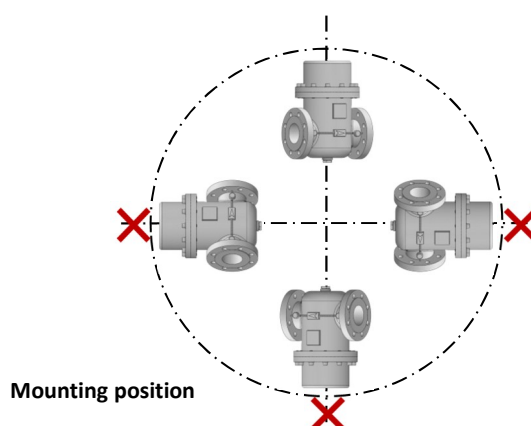

Gas Filter, GS Serie

Dimensions and Weights

Angle Filters

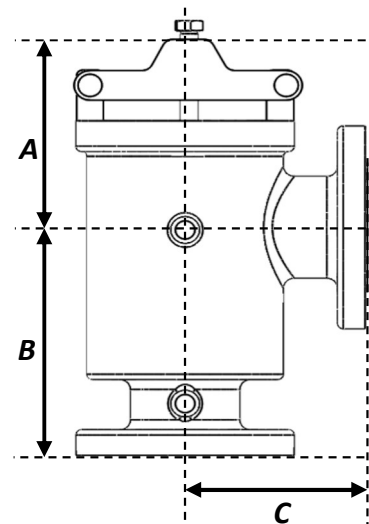

Diameter	A	B	C	Cartridge Surface	Cartridge Type	Internal Volume Lt	Wgt kg
DN25 1"	65	90	90	0,060	G 0.5	2,7	14
DN32 1 1/4"	65	90	90	0,060	G 0.5	2,7	16
DN40 1 1/2"	65	90	90	0,060	G 0.5	2,7	17
DN50 2"	200	150	150	0,060	G 0.5	2,7	18
DN65 2 1/2"	200	150	150	0,230	G 1.5	8,0	45
DN80 3"	210	200	200	0,230	G 1.5	8,0	47
DN100 4"	220	250	250	0,230	G 1.5	8,0	51
DN125 5"	280	350	350	0,725	G 2.5	15,0	130
DN150 6"	280	350	350	0,725	G 2.5	15,0	134

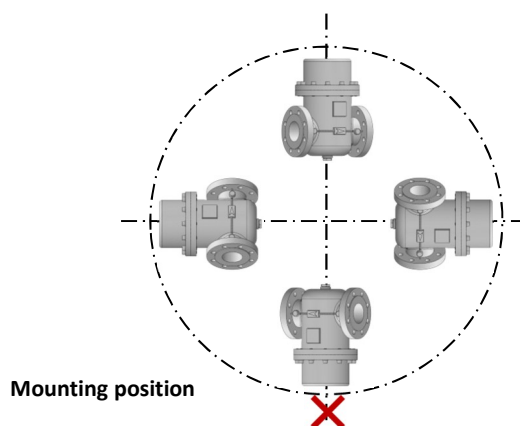



REPLACING the CARTRIDGE GAS FILTER

Gas Filter, GS Serie

Equipment List for Maintenance and Repair

You must have the following hand tools for maintenance and repair. Check that the hand tools you use comply with the standards in your country.

Equipment	DN25 - DN50 1" – 2"	DN65 - DN100 2 1/2" – 4"	DN125-DN150 5"– 6"	Images
Hex Key Wrench T-Handle	8	10	12	

 the unit of all dimensions is mm









Abbreviations will be used in maintenance and repair instructions

Equipment	Abbreviations
Combination Wrench	CW
Hex Key Wrench T-Handle	HK

Gas Filter, GS Serie

Personal Protective Equipmen List

All certified technical personnel must wear personal protective equipment. You must comply with the occupational safety rules of the local authorities you are in. You should use personal protective equipment that complies with the standards of the country you are in. Personal protective equipment must meet at least the following standards

Equipment	Standard	Images
Industrial safety helmet	EN 397:2012+A1:2012	
Safety goggles	EN 166:2001	
Ear muffs	EN 352-1:2002	
Protective coverall	EN 14605+A1	
Visibility vest	EN 20471 : 2013	
Safety shoes	EN 20345: 2004	
Protective mask	EN149:2001	
Safety glove	EN 1082-1:1996	

Gas Filter, GS Serie

GS Serie, 1" – 2"

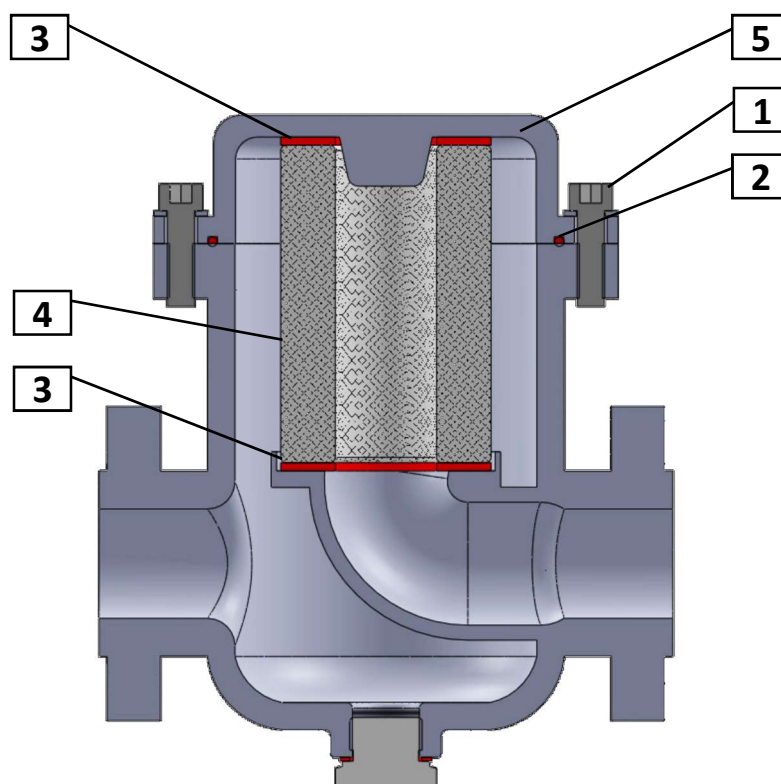

Step	Practice	Equipment and size
1	Turn counterclockwise and remove the screw (1)	HK8
2	Remove the cover (5)	
3	Remove the o-ring (2) from the cover (5). Clean the surface where the o-ring (2) is attached. Lubricate and replace new o-ring (2) with synthetic grease	
4	Remove the leakage plate (3) and cartridge (4)	
5	Fit the new leakage plate (3) and new cartridge (4)	
6	Fit the cover (5)	
7	Turn clockwise and screws the screw (1).	HK8
8	Pressurize the line slowly and perform the leak tests is mandatory	

Before carrying out any work, it is important to ensure that the line on which the filter is installed has been shut off upstream and downstream, and discharged. Tighten all threaded parts with the correct torque.

Gas Filter, GS Serie

GS Serie, 2 1/2" – 4"

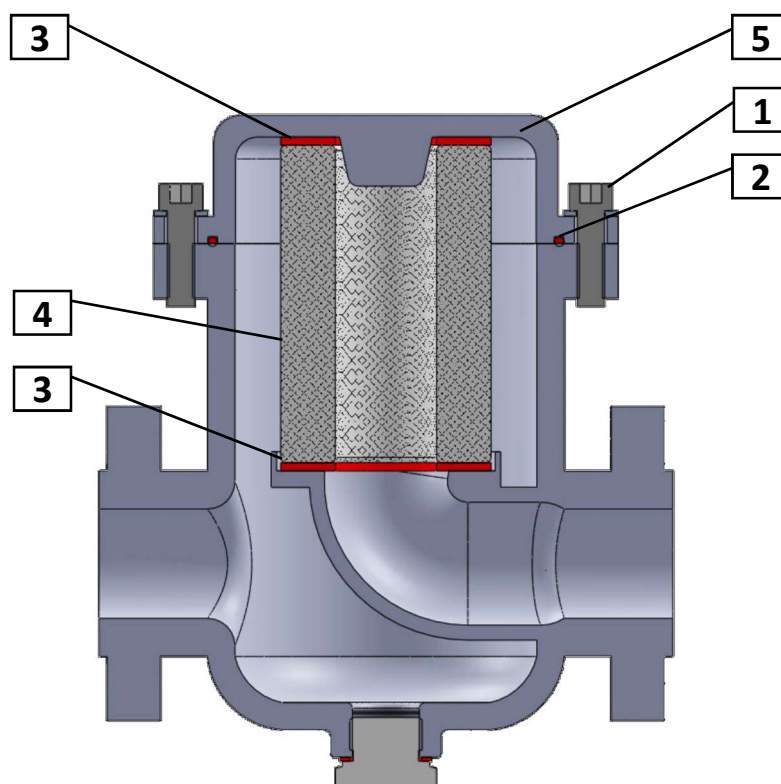

Step	Practice	Equipment and size
1	Turn counterclockwise and remove the screw (1)	HK10
2	Remove the cover (5)	
3	Remove the o-ring (2) from the cover (5). Clean the surface where the o-ring (2) is attached. Lubricate and replace new o-ring (2) with synthetic grease	
4	Remove the leakage plate (3) and cartridge (4)	
5	Fit the new leakage plate (3) and new cartridge (4)	
6	Fit the cover (5)	
7	Turn clockwise and screws the screw (1).	HK10
8	Pressurize the line slowly and perform the leak tests is mandatory	

Before carrying out any work, it is important to ensure that the line on which the filter is installed has been shut off upstream and downstream, and discharged. Tighten all threaded parts with the correct torque.

Gas Filter, GS Serie

GS Serie, 5" – 6"

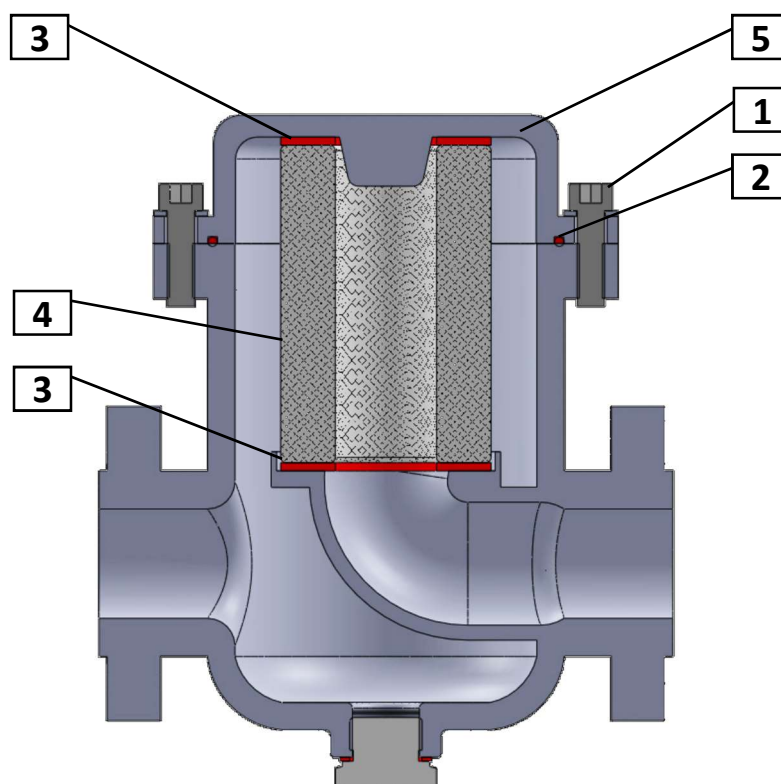

Step	Practice	Equipment and size
1	Turn counterclockwise and remove the screw (1)	HK12
2	Remove the cover (5)	
3	Remove the o-ring (2) from the cover (5). Clean the surface where the o-ring (2) is attached. Lubricate and replace new o-ring (2) with synthetic grease	
4	Remove the leakage plate (3) and cartridge (4)	
5	Fit the new leakage plate (3) and new cartridge (4)	
6	Fit the cover (5)	
7	Turn clockwise and screws the screw (1).	HK12
8	Pressurize the line slowly and perform the leak tests is mandatory	

Before carrying out any work, it is important to ensure that the line on which the filter is installed has been shut off upstream and downstream, and discharged. Tighten all threaded parts with the correct torque.

NOTES

For more information, contact your local sales representative or agency.



info@gastech.com.tr



www.gastech.com.tr



+90 286 501 55 11



gastech_naturalgas



www.linkedin.com/in/gastech-naturalgas-577b931a8/

GASTECH SANAYI VE TICARET ANONIM SİRKETİ
Çanakkale Organize Sanayi Bölgesi, 1. Cadde No:28 17100
Merkez-Çanakkale-TURKEY
Chamber of Commerce Çanakkale, 9492
www.gastech.com.tr info@gastech.com.tr

All rights reserved. 01/2023.

The Gastech logo is a trademark and service mark of GASTECH AS. All other marks are the property of their prospective owners. Gastech™ is a mark owned by one of the companies in the GASTECH AS. Subject to changes and errors. The information given in this document only contains general descriptions and/or performance features which may not always specifically reflect those described, or which may undergo modification in the course of further development of the products. The requested performance features are binding only when they are expressly agreed upon in the concluded contract. GASTECH AS does not assume responsibility for the selection, use or maintenance of any product. Responsibility for proper selection, use and maintenance of any product remains solely with the purchaser.