

SCC Inc.



www.scccombustion.com

Technical Instructions LME-1000

June 11, 2019

LME7... Burner Controls

Combustion Controls

Intentionally Left Blank

Table of Contents

Section 1: Overview

Introduction.....	1
LME7 System Builder	2
Mounting.....	10
Important Safety Notes.....	12
Approvals.....	13

Section 2: LME71 Wiring, Parameters, and Phase Diagrams

LME71 Wiring Diagrams.....	1
LME71 Parameter List	4
LME71 Phase Diagrams	11

Section 3: LME73 Wiring, Parameters, and Phase Diagrams

LME73 Wiring Diagrams.....	1
LME73 Parameter List	4
LME73 Phase Diagrams	9

Section 4: LME75 Wiring, Parameters, and Phase Diagrams

LME75 Wiring Diagrams.....	1
LME75 Parameter List	3
LME75 Phase Diagrams	8

Section 5: Commissioning

Commissioning a New LME7 Burner Control	1
Parameter Backups / Restores	2
Displaying the Flame Signal from the LME7 Burner Control.....	3
Displaying the Actuator Position / PWM Blower Speed from the LME7 Burner Control.....	4
Manually Adjusting the Actuator Position / PWM Blower Speed from the LME7 Burner Control	4
AZL23 Display Unit Icons	4

Section 6: PWM Blowers

Introduction.....1

PWM Blower Fundamentals.....1

Centrifugal Blower Fundamentals2

Blower Speed Monitoring3

Commissioning the LME7 when Using a PWM Blower.....5

Adjusting P0, P1, and P2 via the LME7 Built-in Display7

Adjusting P0, P1, and P2 via the AZL23 Display Unit8

Additional Tips for Burners with PWM Blowers.....9

Section 7: Troubleshooting

Troubleshooting Introduction1

Complete Fault Code List3

Other Common Faults.....7

Section 8: Modbus

Introduction.....1

Physical Connections.....1

Status LED2

Tx/Rx LED.....2

Modbus RTU Connection Details.....3

BACnet MS/TP Connection Details4

Using the OCI417 Configuration Utility.....5

Updating the OCI417.10 Firmware.....7

Modbus Mapping.....8

BACnet Mapping.....11

Unused Inputs.....13

Section 9: ACS410

ACS410 Software Introduction	1
Software Installation	2
Connecting to a PC.....	3
Saving a Parameter Set to a PC	4
Uploading a Parameter Set to an LME7	5
Creating an LME7 Startup Report.....	6
Synchronizing the LME7 and PME Parameters	7
Saving and Viewing Trends.....	8
Viewing the Status Screen.....	10

Appendix A: Application Guide

Honeywell Modutrol IV Motor with the LME75.....	3
Two Flame Detectors	13

Intentionally Left Blank

Section 1

Overview

Section 2

LME71 Wiring, Parameters,
and Phase Diagrams

Section 3

LME73 Wiring, Parameters,
and Phase Diagrams

Section 4

LME75 Wiring, Parameters,
and Phase Diagrams

Section 5

Commissioning

Section 6

PWM Blowers

Section 7

Troubleshooting

Section 8

Modbus

Section 9

ACS410

Appendix A

Application Guide

Section 1

Overview

Section 2

LME71 Wiring, Parameters,
and Phase Diagrams

Section 3

LME73 Wiring, Parameters,
and Phase Diagrams

Section 4

LME75 Wiring, Parameters,
and Phase Diagrams

Section 5

Commissioning

Section 6

PWM Blowers

Section 7

Troubleshooting

Section 8

Modbus

Section 9

ACS410

Appendix A

Application Guide

Introduction

The LME7 burner control is ideally suited for use in industrial thermal process applications. The LME7 is extremely flexible, and encompasses the following features:

- Accepts standard UV, self-check UV, or self-check IR scanners and/or flame rods
- Integral LED display
- Programmable purge times and safety times
- Programmable actuator positions for purge, ignition, and low fire
- Adjustable time overlap of spark ignition and pilot valve
- Adjustable time overlap of pilot and main gas valves
- Proof-of-closure (POC) switch monitoring
- Modbus RTU or BACnet MS/TP communication
- Optional gas valve proving function
- Password-protected access to OEM parameters
- Integrated actuator control
- Integrated PWM blower control



Figure 1-1: The Main Components of an LME7 System

LME7 System Builder

The LME7 burner control system is comprised of many components. Use the following pages to choose the components needed for your specific application.

Control Panel Components

Base Unit – Qty (1) Required

Choose one of the following LME7 base unit options. See page 10 for mounting information.



LME71.000A1	Flame safeguard, without actuator control, without self-check scanner capability, 110V
LME73.000A1	Flame safeguard, with actuator control, without self-check scanner capability, 110V
LME75.000A1	Flame safeguard, with actuator control, with self-check scanner capability, 110V

Program Module – Qty (1) Required

Choose one of the following PME7 program modules. The program module contains the program sequence used to operate the burner.



	Base Unit	Controls Actuator	Actuator Control Can Be Disabled	Controls PWM Blower	Flame Rod	Non-Self-Checking UV Scanner	Self-Checking UV or IR Scanner	Valve Proving	Purge	Independent Ignition Position	Analog Input for Fire Rate
PME71.111A1	LME71.000A1				•	•			•		
PME71.112A1					•	•					
PME71.901A1				•	•	•		•	•		•
PME73.811A1	LME73.000A1	•			•	•		•	•		•
PME73.812A1		•			•	•			•	•	•
PME73.840A1		•	•			•	•		•		
PME75.811A1	LME75.000A1	•	•		•		•	•	•		•
PME75.812A1		•	•		•		•		•	•	•

Plug Set – Qty (1) Required

The terminal plug set for the LME7 is sold separately. Each LME7 needs one plug set.

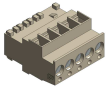
**AGG3.710**

Plug set containing all terminals for an LME7 system

LME7 Package - Optional

For convenience, the LME7 base unit, PME7 program module, and AGG3.710 plug set can be ordered as a package that is shipped pre-assembled.



LME71.111A1PKG	LME71.000A1 with PME71.111A1 program module and AGG3.710 plug set installed
LME71.112A1PKG	LME71.000A1 with PME71.112A1 program module and AGG3.710 plug set installed
LME71.901A1PKG	LME71.000A1 with PME71.901A1 program module and AGG3.710 plug set installed
LME73.811A1PKG	LME73.000A1 with PME73.811A1 program module and AGG3.710 plug set installed
LME73.812A1PKG	LME73.000A1 with PME73.812A1 program module and AGG3.710 plug set installed
LME73.840A1PKG	LME73.000A1 with PME73.840A1 program module and AGG3.710 plug set installed
LME75.811A1PKG	LME75.000A1 with PME75.811A1 program module and AGG3.710 plug set installed
LME75.812A1PKG	LME75.000A1 with PME75.812A1 program module and AGG3.710 plug set installed

Remote Display – Optional

Each LME7 can be equipped with a remote display that provides additional status information not shown by the integral LED display on the LME7. Either the remote display or the ACS410 software are required to change parameter settings on the LME7. See page 11 for mounting information and panel cutout dimensions.



AZL23.00A9

Backlit remote display

Remote Display Cable – Qty (1) Required if Using the AZL23.00A9 Remote Display

This cable is required when using an AZL23 display to connect the AZL23 to the LME7 base unit.



TDCCOMBO

Pre-made 7 foot cable and adapter for connecting the AZL23 display to the LME7 base unit

Interface Modules and Accessories – Optional

A separate interface module is required for Modbus or BACnet MS/TP communication with the LME7.



OCI417.10

Modbus and BACnet MS/TP interface module



TDC207

7 foot cable to connect OCI417.10 to LME7 base unit

Fuses - Optional

The LME7... base units do not have a built-in replaceable fuse. It is recommended to install an external fuse on the incoming power to the LME7.



FUSE6.3A-SLOW

5-pack of 6.3A, 250V, 5x20mm, slow blow fuses

Actuators and Accessories

Actuator – Qty (1) Optional with LME73 and LME75 Burner Controls

SQM4... and SQM5... series actuators are available for use with the LME73 and LME75 burner controls. For more information on SQM4... actuators, refer to Document No. N7817. For more information on SQM5... actuators, refer to Document No. 155-517P25.



SQM4...

45-160 in-lb torque, NEMA 4 standard, up to three adjustable switches, zero and span adjustment



SQM5...

90-400 in-lb torque, NEMA 4 optional, auto/manual toggle switch, six adjustable position switches, zero and span adjustment

Couplings – Optional

Zero-lash, flexible couplings are available for SQM... actuators. For more information, refer to Document No. CPBK-1000.



Cxx...

Flexible couplings for SQM... actuators

Actuator Mounting Bracket Kits - Optional

Modular bracket kits are available to assist in mounting an SQM... actuator to a variety of valves or dampers. A coupling is necessary when using a modular bracket kit. For more information, refer to Document No. CPBK-2000.







BR-AS...

Modular bracket kits for mounting SQM... actuators to a variety of valves or dampers

Flame Scanners

Flame Scanners – Qty (1) Required Unless Using a Flame Rod

Four flame scanners are available for use with the LME7. For technical information about these flame scanners, refer to Document No. N7711 for the QRA4.U, Document No. N7719 for the QRI... flame scanners, and Document No. N7712 for the QRA75.A17.

	QRA4.U	Ultraviolet (UV) flame scanner, non-self-checking, forward viewing, with 3/4" NPSM connection, for use with LME71 or LME73 base units
	QRA75.A17	Ultraviolet (UV) flame scanner, self-checking, side viewing, for use with LME75 base units
	QRI2A2.B180B	Infrared (IR) flame scanner, self-checking, forward viewing, for use with LME75 base units
	QRI2B2.B180B	Infrared (IR) flame scanner, self-checking, side viewing, for use with LME75 base units

Flame Scanner Accessories

QRA75 Wiring Cable – Qty (1) Required per QRA75.A17 Flame Scanner

A pre-made 12 foot cable is required when using the QRA75.A17 flame scanner. For more information, refer to Document No. N7712.

	AGM23U	Pre-made 12 foot cable for use with the QRA75.A17 flame scanner. Supplied with 1/2" NPSM conduit adapter
---	---------------	--

QRA75.A17 Accessories - Optional

Mounting accessories are available for the QRA75.A17 flame scanner. For more information, refer to Document No. N7712.

**AGG16.U**

Right angle adapter for mounting a QRA75 flame scanner. Comes with a 1" NPSM female thread connection

**THERMAL-1X75**

Thermal barrier for use with the QRA75 flame scanner along with accessory AGG16.U. Adapts a 1" NPSM thread to a female 3/4" NPT connection

**AGG03**

Magnifying lens with spring washer and O-ring for increased sensitivity, to be mounted inside thermal barrier THERMAL-1X75

QRI... Accessories - Optional

Mounting accessories are available for both the forward viewing and side viewing QRI... flame scanners. For more information, refer to Document No. N7719.

**AGG2.110**

Kit for mounting forward viewing scanner QRI2A2.B180B on a flame tube. Comes with clamp, mounting sleeve, thermal barrier with 3/4" NPSM connection, and heat insulation glass

**AGG2.120**



Pg9 thread to 1/2" NPSM conduit connection adapter for use with any QRI... flame scanner

**AGG90.U**

Right angle adapter for mounting side viewing scanner QRI2B2.B180B on a flame tube. Comes with 3/4" NPSM female thread connection

Additional Flame Scanner Accessories – Optional

Additional accessories are available for flame scanners to prevent heat from getting to the scanner. For more information, refer to Document No. N7711 and Document No. N7712.

	THERMAL-75X75	Thermal barrier for use with the QRA4.U flame scanner, and QRI2B2.B180B flame scanner when used with right angle adapter AGG90.U. Adapts a 3/4" NPSM thread to a female 3/4" NPT connection. Rated for scanner tube temperatures up to 250 °F
	AGG02	Heat insulating lens with spring washer and O-ring, for applications where the temperature at the scanner will exceed 176 °F. Can be mounted inside thermal barriers THERMAL-75X75 or THERMAL-1X75

ACS410 Software for Laptop

The ACS410 software for the LME7 offers many features including parameter backups, startup reports, and trending. The software may be downloaded at www.scccombustion.com.

ACS410 Cables – Qty (1) Required if Using the ACS410 Software

To use the ACS410 software, cables are necessary to connect the LME7 to a PC.

OCI410.20	User-level PC interface module and cable. Permits access to user level parameters only without the ability to perform parameter backups
	OCI410.30
Service-level PC interface module and cable. Permits access to user and service level parameters and the ability to perform parameter backups	OCI410.40
OEM-level PC interface module and cable. Permits access to all parameters and the ability to perform parameter backups	

Enclosures

Enclosures - Optional

A small NEMA 1 enclosure is available for use with any LME7... base unit. Three ½" conduit knockouts are available on both the top and the bottom of the enclosure.

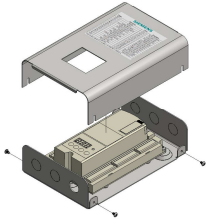

LME7-ENC-KT

NEMA 1 enclosure for any LME7... base unit

Trainers

Trainers - Optional

Training units are available to train OEMs and field technicians how to program and use the various features of the LME75 burner control.



TR-L75-1A

LME75 training unit, 110 VAC

Mounting

LME7 Controller

The LME7 must be mounted inside an enclosure that will protect it from dirt and moisture. The unit should be mounted with three #8 screws (not provided). The panel, which the unit sits on, should be drilled and tapped to accommodate these screws.

During the mounting process, consideration should be given to the various plugs and wires that must be attached to the LME7. Electrical connections are made via plugs that are located in the face of the unit with wires coming out to the top, left side, and right side of the unit. A space of at least one inch is recommended above, to the left, and to the right of the LME7. The recommended total space to leave for the LME7 is 8" x 6.75" x 3" because the overall dimensions of the LME7 are 7.09" x 4.72" x 2.07".

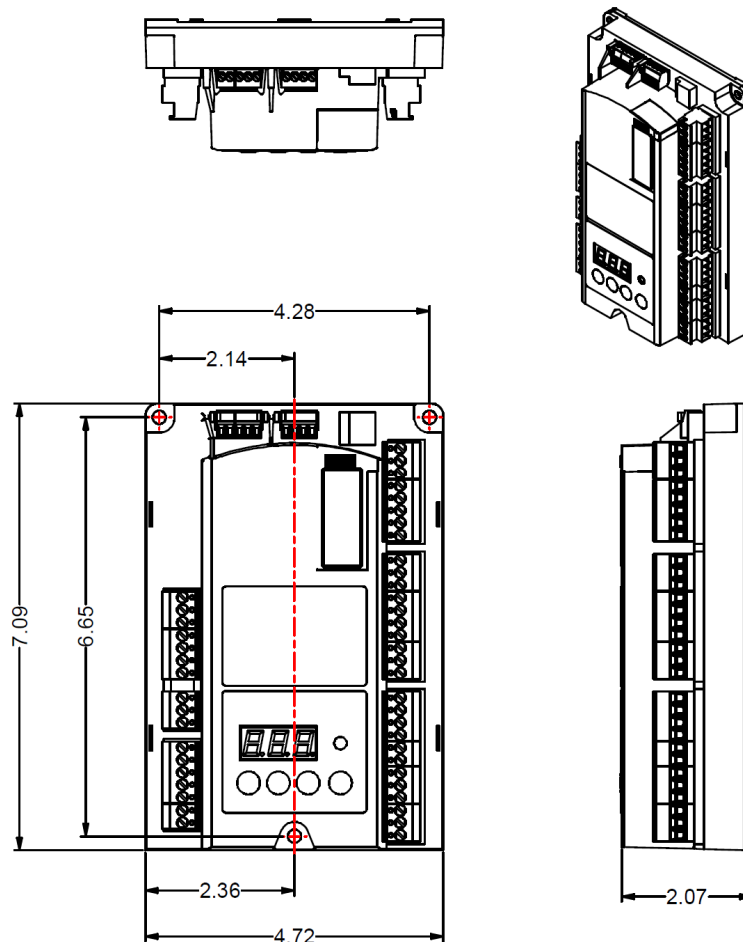

Figure 1-2: LME7 Dimensions (inches)

AZL23 Display

The AZL23 is designed to be mounted in a rectangular cutout through the face / door of an electrical enclosure. It has one screw on the top and another on the bottom that engage small plastic tabs which will swing out when the screw is tightened clockwise; the screw can be loosened to retract the tab and increase clearance before tightening. The tab will pinch the sheet metal of the enclosure door between itself and the AZL23 gasket. This facilitates easy removal and replacement of the AZL23 since it is designed to be taken out of the enclosure face and held in the hands for setup and commissioning.

The AZL23 connects to the LME7 at terminal X56 with cable **TDCCOMBO**. The AZL23 has an IP54 rating when mounted in an electrical enclosure.

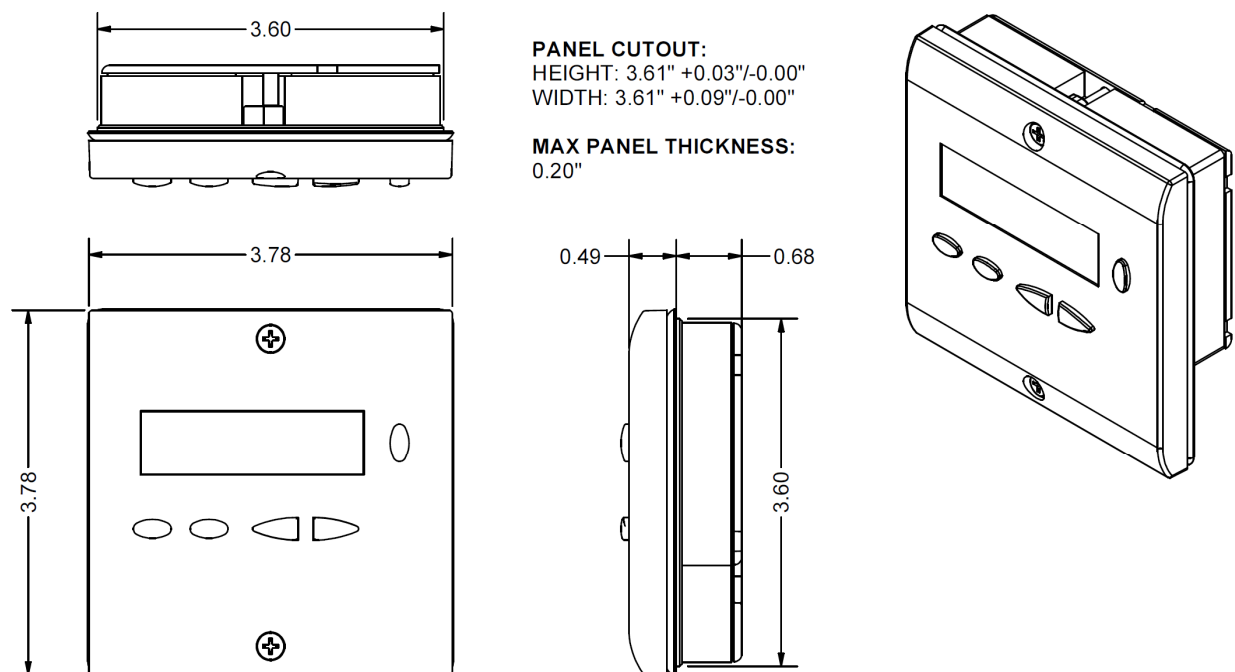

Figure 1-3: AZL23 Dimensions (inches)

Important Safety Notes

- The LME7 is a safety device. Under no circumstances should the unit be modified or opened. SCC Inc. will not assume responsibility for damage resulting from unauthorized modification of the unit.
- All activities (mounting, installation, service work, etc.) must be performed by qualified staff.
- Before performing any work in the connection area of the LME7, disconnect the unit from the main supply (all-polar disconnection).
- Protection against electrical shock hazard on the LME7 and all other connected electrical components must be ensured through good wiring and grounding practices.
- Fall or shock can adversely affect the safety functions of an LME7. Such units must not be put into operation, even if they do not exhibit any apparent damage.
- Condensation and the entry of water into the unit must be avoided.

Approvals

The LME7 has the following standards and approvals:



Applied directives:

- Low-voltage directive 2014/35/EC
- Directive for pressure devices 2014/68/EC
- Gas Appliances Regulation (EU) 2016/426
- Electromagnetic compatibility EMC (immunity) *) 2014/30/EC

*) The compliance with EMC emission requirements must be checked after the burner control is installed in equipment

Compliance with the regulations of the applied directives is verified by the adherence to the following standards / regulations:

- Automatic burner control systems for burners and appliances burning gaseous or liquid fuels DIN EN 298
- Safety and control devices for gas burners and gas burning appliances DIN EN 13611
- Automatic electrical controls for household and similar use Part 2-5: Special requirements on automatic electric burner control and monitoring systems DIN EN 60730-2-5
- Safety and control devices for gas burners and gas burning appliances - Valve proving systems for automatic shut-off valves DIN EN 1643

The relevant valid edition of the standards can be found in the declaration of conformity!

Note on DIN EN 60335-2-102

Household and similar electrical appliances - Safety - Part 2-102: Particular requirements for gas, oil and solid-fuel burning appliances having electrical connections. The electrical connections of the LME7 and the PME7 comply with the requirements of EN 60335-2-102.



EAC Conformity mark (Eurasian Conformity mark)



ISO 9001:2015
ISO 14001:2015
OHSAS 18001:2007



China RoHS
Hazardous substances table:
<http://www.siemens.com/download?A6V10883536>



Only AC 120 V versions



Intentionally Left Blank

Section 1	Overview
Section 2	LME71 Wiring, Parameters, and Phase Diagrams
Section 3	LME73 Wiring, Parameters, and Phase Diagrams
Section 4	LME75 Wiring, Parameters, and Phase Diagrams
Section 5	Commissioning
Section 6	PWM Blowers
Section 7	Troubleshooting
Section 8	Modbus
Section 9	ACS410
Appendix A	Application Guide

Section 1

Overview

Section 2

**LME71 Wiring,
Parameters, and
Phase Diagrams**

Section 3

LME73 Wiring, Parameters,
and Phase Diagrams

Section 4

LME75 Wiring, Parameters,
and Phase Diagrams

Section 5

Commissioning

Section 6

PWM Blowers

Section 7

Troubleshooting

Section 8

Modbus

Section 9

ACS410

Appendix A

Application Guide

LME71 Wiring Diagrams

PME71.111A1 – Pilot or direct spark; with purge; no actuator control; no valve proving

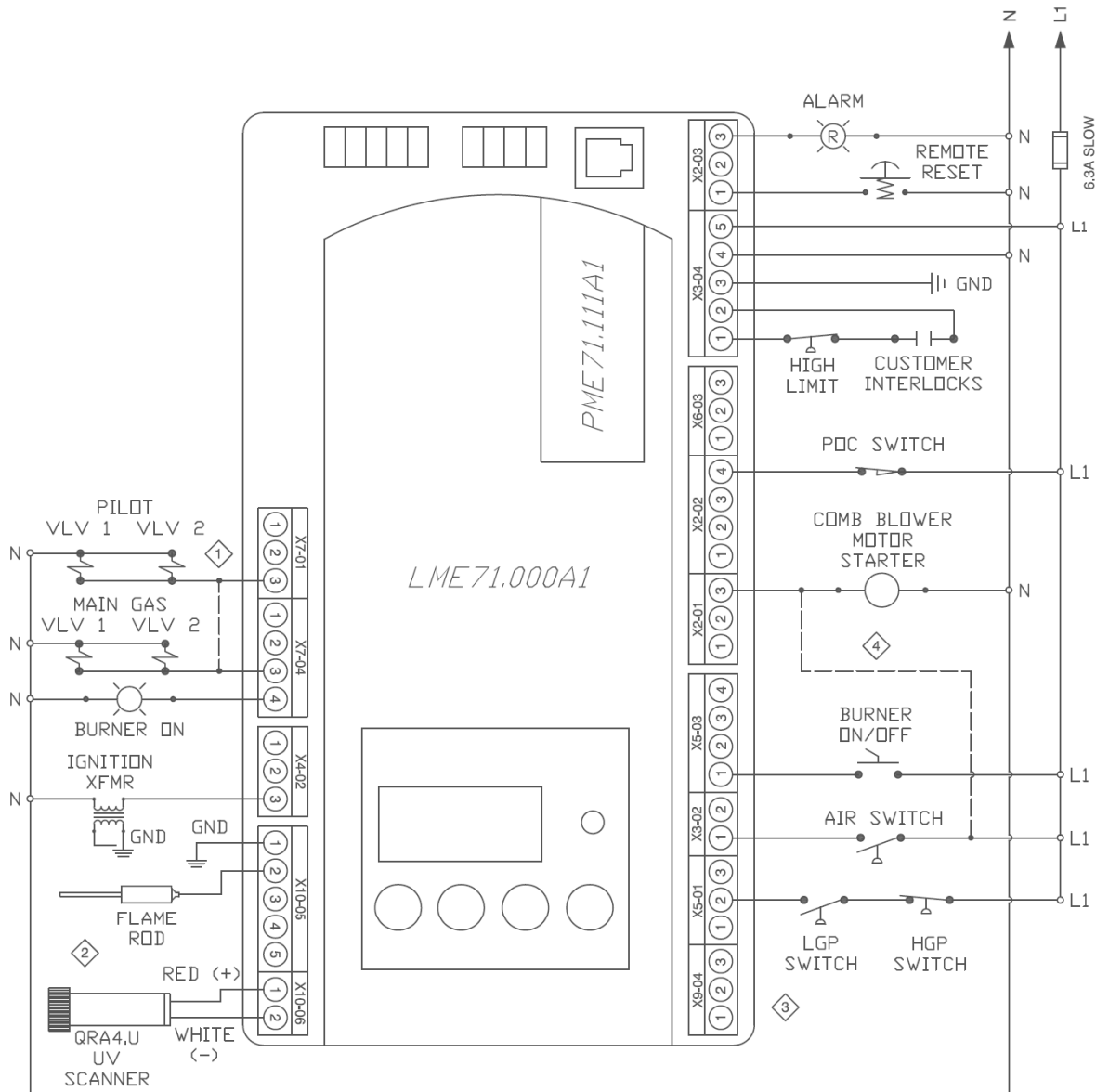

NOTES:

- ① Add a jumper between X7-01.3 and X7-04.3 for direct spark ignition.
- ② Connect either a flame rod or UV scanner (QRA4.U), not both.
- ③ Do not connect wires to any unused terminals.
- ④ When the LME7 isn't controlling the combustion air blower, wire the combustion air switch between X2-01.3 & X3-02.1. Be sure to remove X2-01.3 to N, and X3-02.1 to L1.

PME71.112A1 – Pilot or direct spark; no purge; no actuator control; no valve proving

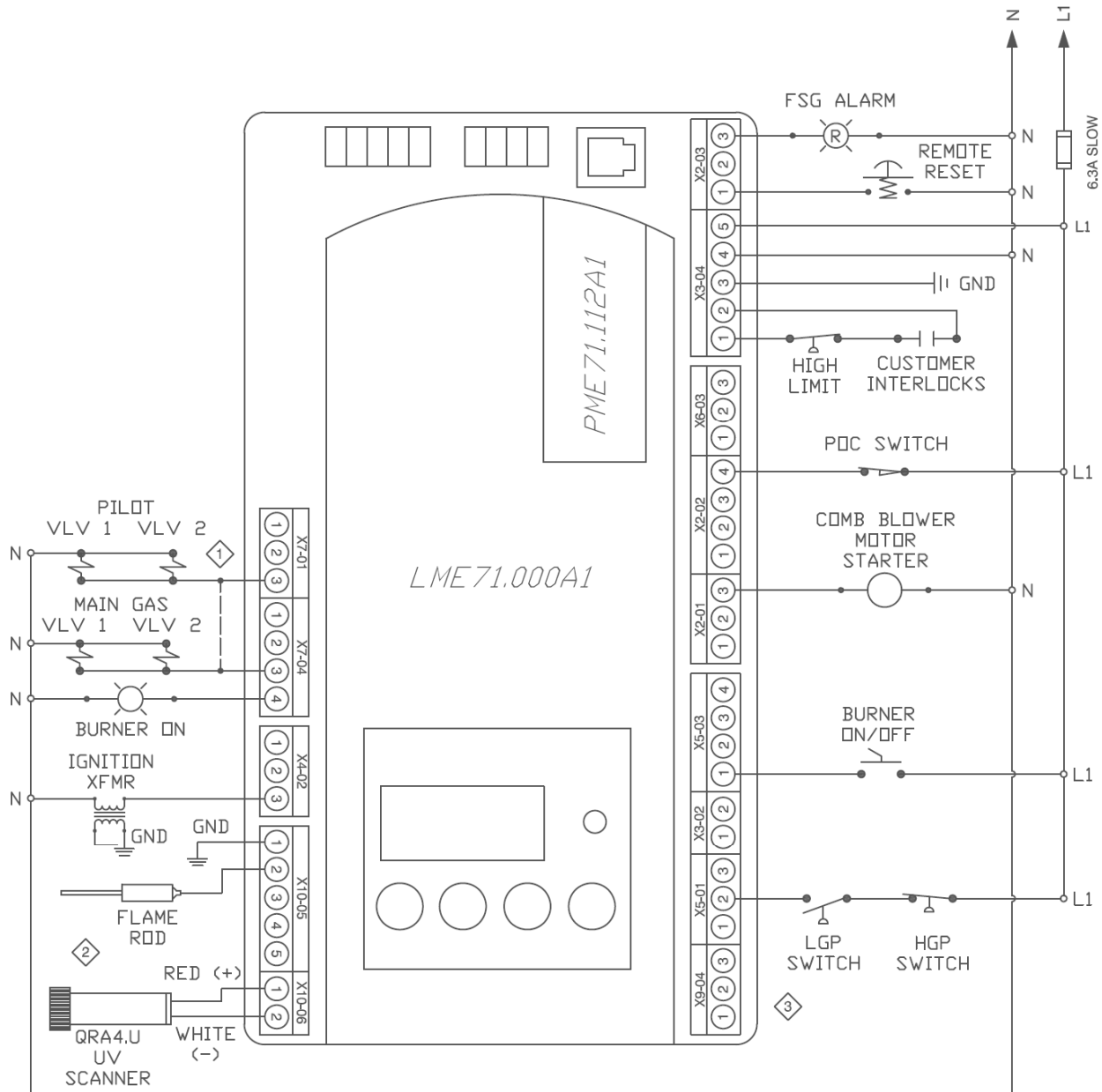

NOTES:

- ① Add a jumper between X7-01.3 and X7-04.3 for direct spark ignition.
- ② Connect either a flame rod or UV scanner (QRA4.U), not both.
- ③ Do not connect wires to any unused terminals.

PME71.901A1 – PWM blower control; direct spark only; valve proving; no actuator control

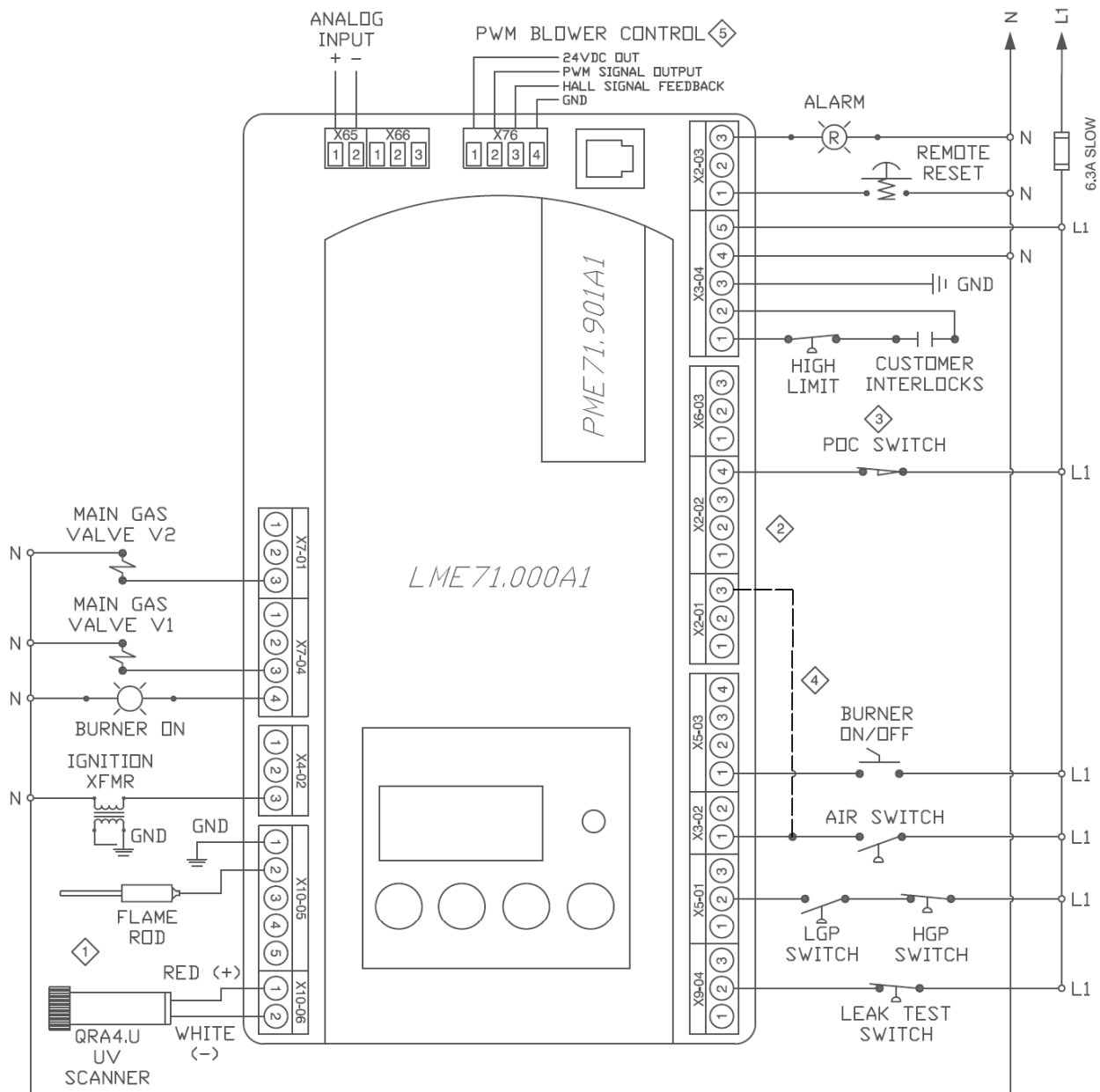

NOTES:

- ① Connect either a flame rod or UV scanner (QRA4.U), not both.
- ② Do not connect wires to any unused terminals.
- ③ When no POC switch is being used, place a jumper from L1 to X2-02.4.
- ④ When no air switch is being used, set parameter 235 = 0 or install a jumper between X2-01.3 and X3-02.1. Be sure to remove X3-02.1 to L1.
- ⑤ Main power to the PWM blower should not be sourced from the LME7.

Parameter Number	Parameter Name	LEGEND - Password Level: S = Service; O = OEM; S/O = View - Service, Write - OEM; Info = Info Menu; Ser = Service Menu Shaded Parameters = Frequently Used				PME71. 111A1	PME71. 112A1	PME71. 901A1
		PW Level	Default	Range	Description			
000 Level: Parameter Backup / Restore / Change Passwords								
041	Service Level PW	O	7173	Any 4 characters	The service level password can be changed here. It must be exactly 4 characters in length. Enter the current password, then enter the new password twice to change it (c = current, n = new, r = repeat).	•	•	•
042	OEM Level PW		L7unI	Any 5 characters	The OEM level password can be changed here. It must be exactly 5 characters in length. Enter the current password, then enter the new password twice to change it (c = current, n = new, r = repeat).	•	•	•
060	Backup / Restore	S	Backup - 0 Restore - 0	0-1	Used to perform parameter backups and restores. Backup: Transfer LME7 parameters to PME7. Restore: Transfer PME7 parameters to LME7. Set parameter to 1 and press the info button to begin the backup or restore. Once a parameter backup is successful, the screen will display "bAC End". Once a parameter restore is successful, the screen will display "rSt End".	•	•	•
100 Level: General Information / Display Mode								
102	Production Date	Info	Read only		Date that the LME7 was produced in the DD.MM.YY format.	•	•	•
103	Serial Number				Serial number of the LME7.	•	•	•
113	Burner ID		Not set	0-99999999	The burner ID can be viewed through the AZL23 but can only be set using the ACS410 software. The burner ID must be all digits (no letters), from 1-8 digits in length. Typically the burner serial number is used. This serves as an identifier for the parameter set. The burner ID must be set in order to perform a parameter backup to a PC using the ACS410 software. Parameter backups to the PME7 program module can be made without setting the burner ID.	•	•	•
140	Display Mode	S	111 - 1 112 - 1 901 - 4	1-4	Sets what will be displayed by the LME7 integral display. 1 = phase 2 = flame signal (QRA... flame scanner or flame rod) 3 = not used 4 = load	•	•	•
164	Startups	Info	Reset only		Displays the total number of startups. To reset this value, press and hold the info button until the value begins to flash, then let go. The value will automatically change to 0. Press the info button again to confirm the reset.	•	•	•
166	Total Startups				Displays the total number of startups. Not resettable.	•	•	•
170	Number of Relay Cycles		Read only		Displays the number of cycles on different internal relays in the LME7. Index 00 = K12 relay cycles Index 01 = K11 relay cycles Index 02 = K2 relay cycles Index 03 = K1 relay cycles	•	•	•
171	Max Relay Cycles				Displays the maximum number of relay cycles allowed on the internal relays of the LME7.	•	•	•

Parameter Number	Parameter Name	LEGEND - Password Level: S = Service; O = OEM; S/O = View - Service, Write - OEM; Info = Info Menu; Ser = Service Menu Shaded Parameters = Frequently Used				PME71. 111A1	PME71. 112A1	PME71. 901A1
		PW Level	Default	Range	Description			
200 Level: Burner Control								
224	Time Air Pressure Switch	S/O	13.818 sec	0-13.818 sec	Once the LME7 reaches phase 22 for the second time (between phases 24 and 30), this sets the length of time the LME7 will wait for air pressure switch input X3-02.1 to become energized before a lockout occurs due to lack of air pressure. As soon as the switch is made, the sequence progresses.			•
225	Prepurge Time		111 - 29.106 sec 901 - 19.404 sec	0-1237 sec	Sets the prepurge time (length of phase 30). The LME7 has a base prepurge time of 2.1 seconds. This setting adds seconds to the base time.	•		•
226	Pre-Ignition Time		3.087 sec	1.029-37.485 sec	The period of time that the ignition transformer (output X4-02.3) is energized before the main valves are opened. Sets the length of phase 38.			•
230	Pilot / Main Stabilization Time		111 - 3.234 sec 112 - 3.234 sec 901 - 15.582 sec	3.234-74.97 sec	On PME71.111A1 and PME71.112A1, this setting defines the pilot stabilizing period if a pilot is used. During this period, only the pilot valve is open. The spark is de-energized. On PME71.901A1, this setting defines the main stabilizing period. During this time, only the main valves are open. The spark is de-energized. Sets the length of phase 44.	•	•	•
231	Pilot and Main Overlap Time		9.996 sec	0-74.97 sec	When a fuel train with a pilot is used, this setting defines the overlap of the pilot (output X7-01.3) and the main fuel valves (output X7-04.4). After this time expires, the pilot is de-energized. Sets the length of phase 50.	•	•	
234	Postpurge Time		111 - 19.404 sec 901 - 4.851 sec	0-1237 sec	Sets the postpurge time (length of phase 74).	•		•
235	Air Pressure Switch		0	0-1	This setting activates or deactivates the air pressure switch input X3-02.1. 0 = deactivated 1 = activated			•
237	POC Switch	S	1	0-2	This setting defines the function of POC switch input X2-02.4. 0 = deactivated 1 = activated (verify POC switch is closed on startup and shutdown) 2 = activated (verify POC switch is closed on startup and shutdown, and open during operation)	•	•	
239	Forced Intermittent	S/O	0	0-1	When activated, this forces the LME7 to shut the burner down every 24 hours of uninterrupted operation. The burner will automatically restart afterwards. The purpose of the shutdown is to check and cycle safety devices. The PME73.840A1 will recycle every 24 hours. 0 = deactivated 1 = activated	•	•	
240	Repetition Flame		0	Index 00 = 0-2 Index 01 = 0-4	This sets the numbers of times a flame failure must occur before causing a lockout. Most North American codes require 1. Index 00 = flame failures during operation Index 01 = flame failures during main trial for ignition 0 = no repetitions 1 = no repetitions 2 = 1 repetition 3 = 2 repetitions 4 = 3 repetitions	•	•	•

Parameter Number	Parameter Name	LEGEND - Password Level: S = Service; O = OEM; S/O = View - Service, Write - OEM; Info = Info Menu; Ser = Service Menu Shaded Parameters = Frequently Used				PME71.111A1	PME71.112A1	PME71.901A1
		PW Level	Default	Range	Description			
241.00	Valve Proving Activation	S/O	0	0-1	This setting determines if gas valve proving (leak testing) will be performed. Gas valve proving can be performed on startup, shutdown, or both depending on the settings of parameters 241.01 and 241.02. 0 = deactivated 1 = activated			•
241.01	Valve Proving Setup 1		1	0-1	Determines at which point during the burner's sequence that valve proving will be performed. Used in conjunction with parameter 241.02. 0 = valve proving on startup 1 = valve proving on shutdown			•
241.02	Valve Proving Setup 2		0	0-1	Determines at which point during the burner's sequence that valve proving will be performed. Used in conjunction with parameter 241.01. 0 = valve proving according to parameter 241.01 1 = valve proving on startup and shutdown			•
242	VP Evacuation Time		2.646 sec	0-2.646 sec	If valve proving is performed, this specifies the length of time that the downstream valve (V2) is energized (output X7-01.3). This will evacuate any gas that might exist between the gas valves. Sets the length of phase 80.			•
243	VP Upstream Test		10.290 sec	1.029-37.485 sec	If valve proving is performed, this specifies the length of time that both the upstream and downstream valves are closed. If the pressure between the valves rises during this period (enough to open the NC valve proving pressure switch), then the upstream valve is leaking and the LME7 will lockout. A longer time period will produce a more sensitive test. Sets the length of phase 81.			•
244	VP Fill Time		2.646 sec	0-2.646 sec	If valve proving is performed, this specifies the length of time that the upstream valve (V1) is energized (output X7-04.4). This will fill the volume between the main gas valves to line pressure. Sets the length of phase 82.			•
245	VP Downstream Test		10.290 sec	1.029-37.485 sec	If valve proving is performed, this specifies the length of time that both the upstream and downstream valves are closed. If the pressure between the valves falls during this period (enough to close the NC valve proving pressure switch), then the downstream valve is leaking and the LME7 will lockout. A longer time period will produce a more sensitive test. Sets the length of phase 83.			•
247	Intermittent Pilot		0	0-1	Sets the type of pilot being used. If set to 1, the pilot valve will remain open from phase 40 to the end of main operation (oP1). 0 = interrupted pilot 1 = intermittent pilot	•	•	
254	Flame Failure Response Time (FFRT)		1	0-1	Sets the flame failure response time (FFRT). The FFRT is the maximum length of time that the flame signal can go away before a lockout occurs. This setting also doubles as the length of time the signal from the air pressure switch can go away before a lockout occurs. On PME71.901A1, the FFRT is fixed at 1 second. 0 = 1 second 1 = 3 seconds	•	•	
257	Trial for Ignition		111 - 4.116 sec 112 - 4.116 sec 901 - 2.205 sec	0-13.23 sec	On PME71.111A1 and PME71.112A1, this setting defines the overlap of the spark (output X4-02.3) and the pilot valve (output X7-01.3) if a pilot is used. On PME71.901A1, this setting defines the overlap of the spark (output X4-02.3) and the main valves. After this time expires, the spark is de-energized. The LME7 has a base time of 0.3 seconds. This setting adds seconds to the base time. Sets the length of phase 40.	•	•	•

Parameter Number	Parameter Name	LEGEND - Password Level: S = Service; O = OEM; S/O = View - Service, Write - OEM; Info = Info Menu; Ser = Service Menu Shaded Parameters = Frequently Used				PME71. 111A1	PME71. 112A1	PME71. 901A1
		PW Level	Default	Range	Description			
400 Level: Blower Speeds								
P0	Ignition Speed	S	3000 RPM	800-9000 RPM	Sets the PWM blower speed during ignition. See Section 6 (PWM Blowers) for more information on setting this value.			•
P1	Low Fire Speed		1200 RPM	400-9000 RPM	Sets the PWM blower speed at low fire. See Section 6 (PWM Blowers) for more information on setting this value.			•
P2	High Fire Speed		5700 RPM	800-9000 RPM	Sets the PWM blower speed at high fire. See Section 6 (PWM Blowers) for more information on setting this value.			•
500 Level: Special Positions / Modulation Ramps / Blower Speed Limits								
503.00	Standby Blower Speed	S	0 RPM	0-9000 RPM	Sets the PWM blower speed when the burner is in standby (off).			•
503.01	Prepurge / Postpurge Blower Speed		5700 RPM	800-9000 RPM	Sets the PWM blower speed during prepurge and postpurge.			•
516.00	Minimum Ignition Speed	S/O	800 RPM	800-9000 RPM	Sets the minimum allowable PWM blower speed during ignition (P0). This should be set to the minimum blower speed at which the burner can still be safely ignited.			•
516.01	Maximum Ignition Speed		9000 RPM	800-9000 RPM	Sets the maximum allowable PWM blower speed during ignition (P0). This should be set to the maximum blower speed at which the burner can still be safely ignited.			•
517.00	Minimum Low Fire Speed		400 RPM	400-9000 RPM	Sets the minimum allowable PWM blower speed when the burner is at low fire (P1). This should be set to the minimum blower speed at which the burner can still be safely operated at low fire.			•
517.01	Maximum Low Fire Speed		9000 RPM	800-9000 RPM	Sets the maximum allowable PWM blower speed when the burner is at low fire (P1). This should be set to the maximum blower speed at which the burner can still be safely operated at low fire.			•
518.00	Minimum High Fire Speed		800 RPM	800-9000 RPM	Sets the minimum allowable PWM blower speed when the burner is at high fire (P2). This should be set to the minimum blower speed at which the burner can still be safely operated at high fire.			•
518.01	Maximum High Fire Speed		9000 RPM	800-9000 RPM	Sets the maximum allowable PWM blower speed when the burner is at high fire (P2). This should be set to the maximum blower speed at which the burner can still be safely operated at high fire.			•
519	Maximum Blower Speed		5830 RPM	3000-9000 RPM	Sets the maximum blower speed according to the PWM blower manufacturer. This value is used to calculate blower speed percentages.			•
522	Ramp Up PWM Blower		14.994 sec	2.058-74.97 sec	This sets the speed that the PWM blower ramps up. This setting is active during operation as well as driving to special positions (standby, prepurge, ignition, postpurge). Large blowers typically require a longer ramp up.			•
523	Ramp Down PWM Blower		14.994 sec	2.058-74.97 sec	This sets the speed that the PWM blower ramps down. This setting is active during operation as well as driving to special positions (standby, prepurge, ignition, postpurge). Large blowers typically require a longer ramp down.			•

Parameter Number	Parameter Name	LEGEND - Password Level: S = Service; O = OEM; S/O = View - Service, Write - OEM; Info = Info Menu; Ser = Service Menu Shaded Parameters = Frequently Used				PME71. 111A1	PME71. 112A1	PME71. 901A1
		PW Level	Default	Range	Description			
558	UDS Mode	S/O	Read only		This parameter is for Siemens use only. 0 = PC tool mode 1 = PWM mode 2 = actuator mode 3 = internally 4 = internally 5 = internally			•
559	Speed Control Mode		1	0-2	This setting activates or deactivates the internal PID control in the LME7. If using a PWM blower that has its own internal speed control, this should be deactivated. 0 = deactivated 1 = activated 2 = test mode			•
560	Ratio Control Mode		Read only		Defines the device being controlled by the LME7 that is used to influence the amount of air to the burner. This value is set by Siemens and cannot be modified. On PME71.901A1, this value should always be set to 1. 0 = none 1 = PWM blower 2 = actuator			•
600 Level: PWM Blower Configuration								
644	Feedback Pulse / Rev	S/O	3	2-5	This sets the expected number of pulses per revolution being output from the PWM blower. This information should be provided by the blower manufacturer.			•
646	Settling Time		2.058 sec	1.029-2.058 sec	The blower speed must lie within tolerance band 1 for this length of time before the target speed is considered reached.			•
650.00	Tolerance Band 1		+/- 1%	+/- 1-5%	Sets an inner tolerance band for blower speed control. Percentages are based on the maximum blower speed (parameter 519). If the actual blower speed falls outside tolerance band 1 for longer than the time set by parameter 660, a lockout occurs.			•
650.01	Tolerance Band 2		+/- 3%	+/- 1-10%	Sets an outer tolerance band for blower speed control. Percentages are based on the maximum blower speed (parameter 519). If the actual blower speed falls outside tolerance band 2, a lockout occurs immediately.			•
654	Analog Input	S	1	0-5	Sets the type of input signal being connected to terminal X65 or X5-03. This input signal is used to determine the blower speed during operation. 0 = 3-position 1 = 0-10 VDC 2 = 0-135 Ohm 3 = 0-20 mA 4 = 4-20 mA with lockout when input is less than 4 mA 5 = 4-20 mA without lockout when input is less than 4 mA			•
658.00	PWM Startup	S/O	25%	1-100%	Sets the minimum PWM signal that the blower needs to receive in order to start the blower from standstill. This information should be provided by the blower manufacturer.			•

Parameter Number	Parameter Name	LEGEND - Password Level: S = Service; O = OEM; S/O = View - Service, Write - OEM; Info = Info Menu; Ser = Service Menu Shaded Parameters = Frequently Used				PME71.111A1	PME71.112A1	PME71.901A1
		PW Level	Default	Range	Description			
658.01	Minimum PWM Signal	S/O	0%	0-20%	Sets a minimum PWM signal that the LME7 will transmit to the PWM blower.			•
658.02	Maximum PWM Signal		100%	80-100%	Sets a maximum PWM signal that the LME7 will transmit to the PWM blower.			•
659.00	Min Ramp Up	S	Read only		For Siemens use only. Sets the minimum allowable value for the ramp up time (parameter 522).			•
659.01	Max Ramp Up				For Siemens use only. Sets the maximum allowable value for the ramp up time (parameter 522).			•
659.02	Min Ramp Down				For Siemens use only. Sets the minimum allowable value for the ramp down time (parameter 523).			•
659.03	Max Ramp Down				For Siemens use only. Sets the maximum allowable value for the ramp down time (parameter 523).			•
660	Tolerance Band 1 Time				For Siemens use only. Sets the amount of time the blower speed can lie outside of tolerance band 1 before a lockout occurs.			•
674	Minimum Speed Change	S/O	40 RPM	0-255 RPM	Only requested speed changes larger than the value of this setting will actually be corrected. This serves as a dead band to protect the PWM blower from constant small speed oscillations.			•
675.00	Minimum PWM Signal Prepurge		86%	0-100%	Sets the minimum allowable PWM signal that the LME7 will transmit to the PWM blower during prepurge. This should be set so that as long as the blower speed remains at or above this setting, a successful prepurge will occur regardless of all other conditions (air temperature, air pressure, undervoltage to blower, etc.)			•
675.01	Maximum PWM Signal Ignition		34%	0-100%	Sets the maximum allowable PWM signal that the LME7 will transmit to the PWM blower during ignition. This should be set so that as long as the blower speed remains at or below this setting, a successful lightoff will occur regardless of all other conditions (air temperature, air pressure, overvoltage to blower, etc.)			•
676	Proportional Band		112	0-255	P-part of the PID loop controlling the blower speed when closed-loop speed control is used. P is the proportional band. Smaller values give a more aggressive response. It is recommended to leave this setting at the default value.			•
677	Integral Time		0.441 sec	0-37.485 sec	I-part of the PID loop controlling the blower speed when closed-loop speed control is used. I is the integral (reset) function. This component serves to eliminate steady-state error by looking at the accumulation of error over a period of time and correcting for it. Smaller values give a more aggressive response. It is recommended to leave this setting at the default value.			•
678	Derivative Time		0 sec	0-37.485 sec	D-part of the PID loop controlling the blower speed when closed-loop speed control is used. D is the derivative function. This component serves to eliminate overshoot caused by the integral value, and also dampen the action of the P and I values. Smaller values give a weaker response. It is recommended to leave this setting at the default value.			•
679.00	Lower Range Time Constant		6.027 sec	0-37.485 sec	Sets the time constant for speed control in the lower speed range when ramping down. It is recommended to leave this setting at the default value.			•
679.01	Medium Range Time Constant		6.027 sec	0-37.485 sec	Sets the time constant for speed control in the medium speed range when ramping down. It is recommended to leave this setting at the default value.			•
679.02	Upper Range Time Constant		6.027 sec	0-37.485 sec	Sets the time constant for speed control in the upper speed range when ramping down. It is recommended to leave this setting at the default value.			•
679.03	Total Range Time Constant		6.027 sec	0-37.485 sec	Sets the time constant for speed control in all speed ranges when ramping up. It is recommended to leave this setting at the default value.			•
680.00	Upper Speed Range Threshold		4000 RPM	800-9000 RPM	Sets the speed threshold between the upper and medium speed ranges for parameters 679.01 and 679.02.			•
680.01	Lower Speed Range Threshold		2000 RPM	800-9000 RPM	Sets the speed threshold between the lower and medium speed ranges for parameters 679.00 and 679.01.			•

Parameter Number	Parameter Name	LEGEND - Password Level: S = Service; O = OEM; S/O = View - Service, Write - OEM; Info = Info Menu; Ser = Service Menu Shaded Parameters = Frequently Used			PME71.111A1	PME71.112A1	PME71.901A1		
		PW Level	Default	Range				Description	
700 Level: Fault History									
701-711	Fault History	Ser	Read only	Shows the current status (fault) along with the 10 most recent faults. 701 = current status, 702 = most recent fault, 703 = next most recent fault, etc. Each fault has indices that provide additional information about the fault: Index 00 = fault code Index 01 = start number Index 02 = phase Index 03 = load			•	•	•
900 Level: Operational Data									
920	Target Speed %	Ser	Read only	Displays the real time target speed of the PWM blower as a percentage of the maximum blower speed (parameter 519). Will always display as a "-" on PME71.111A1 and PME71.112A1.			•	•	•
936	Actual Speed %			Displays the real time actual speed of the PWM blower as a percentage of the maximum blower speed (parameter 519). Will always display as a "-" on PME71.111A1 and PME71.112A1.			•	•	•
951	Incoming Voltage			Displays the real time mains voltage. Measured at terminal X3-04 pin 4 (neutral) and pin 5 (line).			•	•	•
954	Flame Signal			Displays the raw flame signal from 0-100% for any flame scanner type. A flame failure occurs when the flame signal drops below 20% for the time period specified by parameter 254. This signal refers to input terminal X10-06 (UV scanners) or input terminal X10-05.2 (flame rods).			•	•	•

LME71 Phase Diagrams

The Siemens LME7 burner controls can perform a number of different burner sequences based upon which PME7 program module is used, how certain parameters are set, and how the LME7 is wired.

Each program module has an associated phase diagram. The phase diagrams illustrate when input and output terminals are expected to be energized or de-energized. A legend on the bottom of each page describes the various symbols used in the diagrams.

Notes:

- 1) A jumper can be added between terminals X7-04.4 and X7-01.3 for direct spark ignition. If this jumper is added, main valve output X7-04.4 and pilot valve output X7-01.3 will be energized from phase 40 through the end of operation (oP1).
- 2) If the LME7 is set to perform valve proving on startup, valve proving takes place at the same time as prepurge. Phases 80-83 will be displayed on the LME7 and the AZL23 even though prepurge (phase 30) is also occurring at the same time. The actual prepurge time will be at least the sum of all four valve proving time parameters (242, 243, 244, 245).
- 3) If the LME7 is set to perform valve proving on shutdown, valve proving takes place at the same time as postpurge. Phases 80-83 will be displayed on the LME7 and the AZL23 even though postpurge (phase 74) is also occurring at the same time. The actual postpurge time will be at least the sum of all four valve proving time parameters (242, 243, 244, 245).

PME71.111A1 Phase Diagram

				Lockout	Standby, Waiting for Call for Heat	Test - Air Pressure Switch Open	Blower On	Prepurge	Trial for Ignition	Flame Detection	Interval 1: Pilot Stabilization	Safety Time 2: Main and Pilot Overlap	Interval 2: Main Stabilization	Operation	Postpurge	Home Run	
				Phase	LOC	OFF	21	22	30	40	42	44	50	50	oP1	74	10
				Param.				225	257		230	231	254	240	234		
				STARTUP										OPERATION	SHUTDOWN		
				SAFETY TIME 1													
	Terminal	Description	Notes														
INPUTS	X3-04.5	Main Voltage															
	X3-04.1	Safety Loop		X	X												X
	X5-03.1	Burner On			M												
	X3-02.1	Air Pressure Switch				X	M										
	X5-01.2	Gas Pressure Switch(es)															
	X10-05.2 X10-06.1/2	Flame Signal			X			X									
	X2-02.4	POC (P237 = 1) POC (P237 = 2)												X			
OUTPUTS	X2-02.3	POC Source		X	X												X
	X6-03.3	Safety Valve		X	X												X
	X2-01.3	Blower		X	X	X											X
	X4-02.3	Ignition Transformer		X	X	X	X	X	X	X	X	X	X	X	X	X	X
	X7-04.4	Main Valve V1	Note 1	X	X	X	X	X	X	X	X	X	X	X	X	X	X
	X2-03.3	Alarm			X	X	X	X	X	X	X	X	X	X	X	X	X
	X7-01.3	Pilot Valve (P247 = 0) Pilot Valve (P247 = 1)	Note 1	X	X	X	X	X						X	X	X	X

Legend :

	Energized		M	Must be energized by end of phase
	Energized or de-energized			
X	De-energized			

PME71.112A1 Phase Diagram

		Lockout	Standby, Waiting for Call for Heat	Test - POC Closed	Blower On	Trial for Ignition	Flame Detection	Interval 1: Pilot Stabilization	Safety Time 2: Main and Pilot Overlap	Interval 2: Main Stabilization	Operation	Home Run
		LOC	OFF	21	22	40	42	44	50	50	oP1	10
		Param.				257		230	231	254	240	
		STARTUP									OPERATION	SHUTDOWN
		Terminal	Description	Notes			SAFETY TIME 1					
INPUTS	X3-04.5	Main Voltage										
	X3-04.1	Safety Loop		X	X							X
	X5-03.1	Burner On			M							
	X5-01.2	Gas Pressure Switch(es)										
	X10-05.2 X10-06.1/2	Flame Signal			X	X	X					
	X2-02.4	POC (P237 = 1) POC (P237 = 2)									X	
OUTPUTS	X2-02.3	POC Source		X	X							X
	X6-03.3	Safety Valve		X	X							X
	X2-01.3	Blower		X	X	X						X
	X4-02.3	Ignition Transformer		X	X	X	X	X	X	X	X	X
	X7-04.4	Main Valve V1	Note 1	X	X	X	X	X	X	X	X	X
	X2-03.3	Alarm			X	X	X	X	X	X	X	X
	X7-01.3	Pilot Valve (P247 = 0) Pilot Valve (P247 = 1)	Note 1	X	X	X	X				X	X

Legend :

	Energized	M	Must be energized by end of phase
	Energized or de-energized		
X	De-energized		

PME71.901A1 Phase Diagram

		Lockout	Standby, Waiting for Call for Heat	Test - Air Pressure Switch Open	Blower On	Drive to Prepurge Speed	Test - Air Pressure Switch Closed	Prepurge (Note 2)	Drive to Ignition Speed	Preignition	Trial for Ignition	Flame Detection	Interval: Main Stabilization	Operation	Drive to Postpurge Speed	Postpurge (Note 3)	Home Run	Evacuate	Atmospheric Test	Fill	Pressure Test				
		LOC	OFF	21	22	24	22	30	36	38	40	42	44	oP	72	74	10	80	81	82	83				
		Param.					224	225		226	257			240		234		242	243	244	245				
		STARTUP												OPERATION	SHUTDOWN		VALVE PROVING								
		Terminal	Description	Notes											SAFETY TIME 1										
INPUTS	X3-04.5	Main Voltage																							
	X3-04.1	Safety Loop																							
	X5-03.1	Burner On		M																					
	X3-02.1	Air Pressure Switch			X		M																		
	X5-01.2	Gas Pressure Switch(es)																							
	X9-04.2	Valve Proving Pressure Switch																				X			
	X10-05.2 X10-06.1/2	Flame Signal		X				X	X																
	X2-02.4	POC																							
OUTPUTS	X2-02.3	POC Source	X																						
	X6-03.3	Safety Valve	X																						
	X2-01.3	Blower	X	X	X																	X			
	X4-02.3	Ignition Transformer	X	X	X	X	X	X	X	X			X	X	X	X	X	X	X	X	X	X			
	X7-04.4	Main Valve V1	X	X	X	X	X	X	X	X	X						X	X	X	X	X	X			
	X7-01.3	Main Valve V2	X	X	X	X	X	X	X	X	X					X	X	X	X	X	X	X			
	X2-03.3	Alarm		X	X	X	X	X	X	X	X	X	X	X	X	X	X	X	X	X	X	X			
PWM Blower Speed		S	S	S	S	T	P	P	T	I	I	I	I	O	T	P	T	P	P	P	P				

Legend :

Energized	Must be energized by end of phase	Ignition speed
Energized or de-energized	Standby speed	Operation - speed determined by input signal
De-energized	Prepurge/postpurge speed	Speed transitioning/modulating

Section 1	Overview
Section 2	LME71 Wiring, Parameters, and Phase Diagrams
Section 3	LME73 Wiring, Parameters, and Phase Diagrams
Section 4	LME75 Wiring, Parameters, and Phase Diagrams
Section 5	Commissioning
Section 6	PWM Blowers
Section 7	Troubleshooting
Section 8	Modbus
Section 9	ACS410
Appendix A	Application Guide

Section 1	Overview
Section 2	LME71 Wiring, Parameters, and Phase Diagrams
Section 3	LME73 Wiring, Parameters, and Phase Diagrams
Section 4	LME75 Wiring, Parameters, and Phase Diagrams
Section 5	Commissioning
Section 6	PWM Blowers
Section 7	Troubleshooting
Section 8	Modbus
Section 9	ACS410
Appendix A	Application Guide

LME73 Wiring Diagrams

PME73.811A1 – Modulating actuator control with valve proving; ignition position = low fire

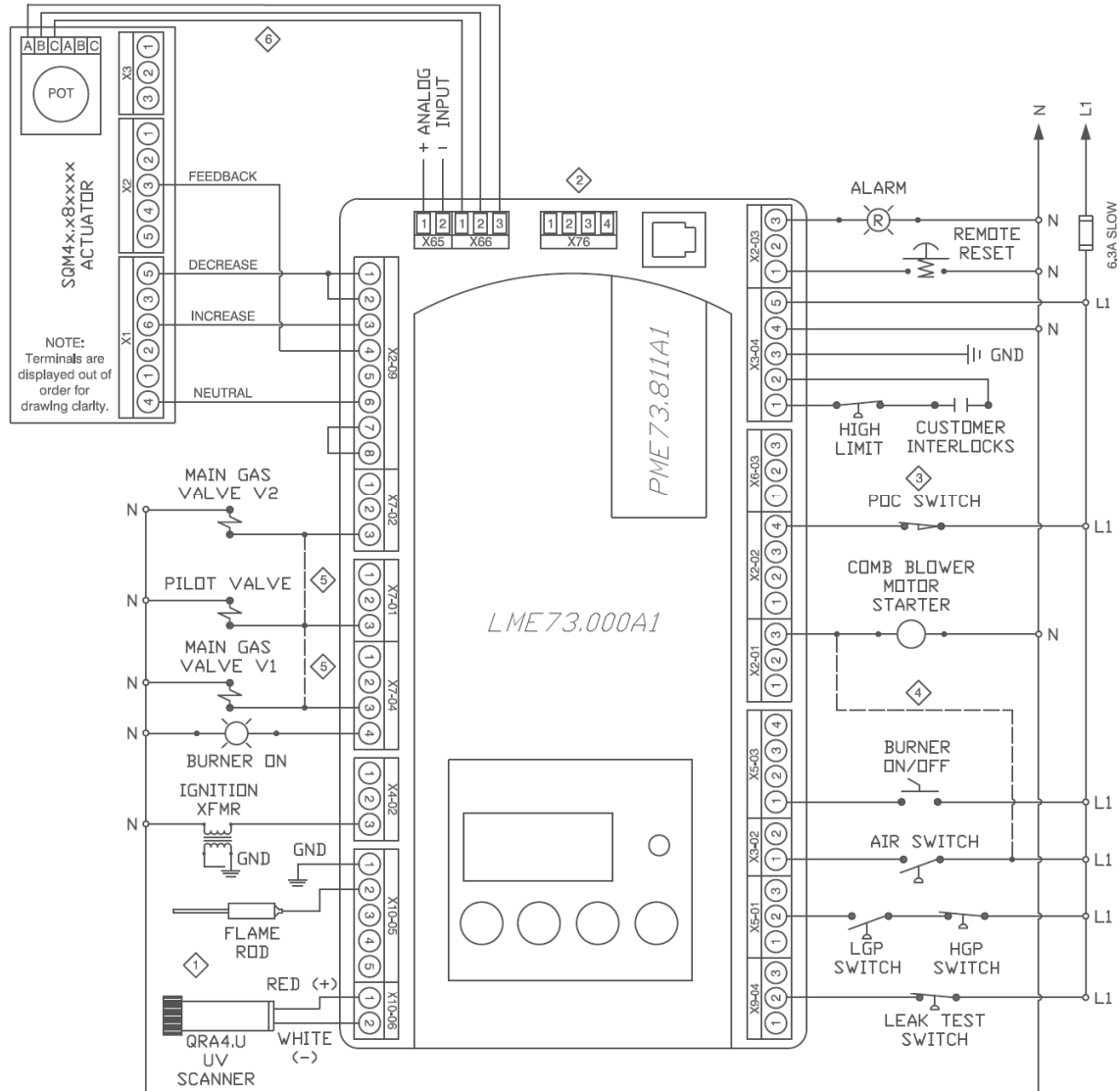

NOTES:

- ① Connect either a flame rod or UV scanner (QRA4.U), not both.
- ② Do not connect wires to any unused terminals.
- ③ When no POC switch is being used, place a jumper from L1 to X2-02.4 or set parameter 237 = 0.
- ④ When the LME7 isn't controlling the combustion air blower, wire the combustion air switch between X2-01.3 and X3-02.1. Be sure to remove X2-01.3 to N, and X3-02.1 to L1.
- ⑤ Add jumpers between X7-01.3 and X7-04.3 and between X7-01.3 and X7-02.3 for direct spark ignition. Valve proving is not possible with direct spark ignition.
- ⑥ Wiring shown is for an SQM40... actuator. If using an SQM41... actuator, swap the wires going to terminals A and C on the potentiometer.

PME73.812A1 – Modulating actuator control with independent ignition position; no valve proving

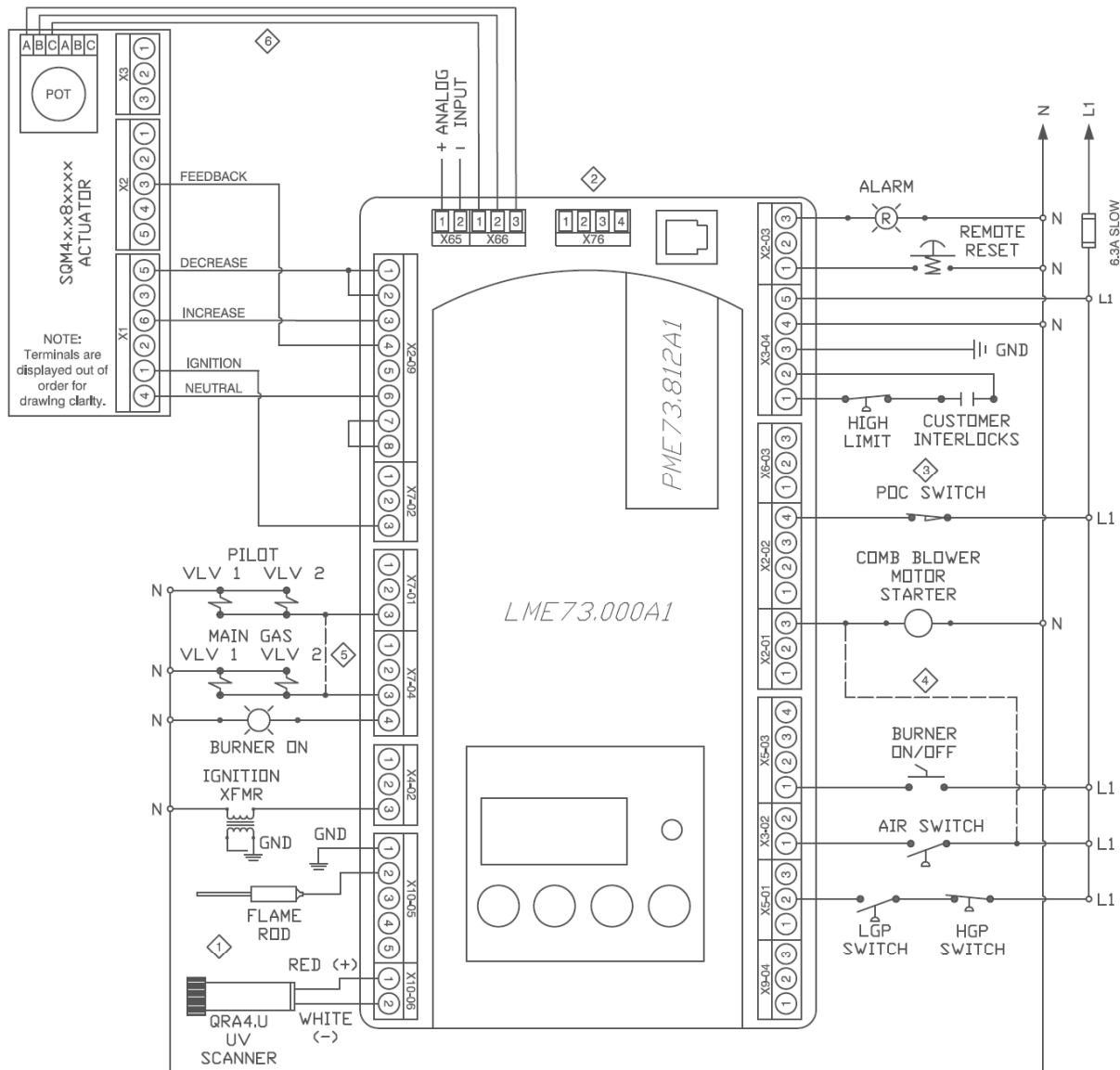

NOTES:

- ① Connect either a flame rod or UV scanner (QRA4.U), not both.
- ② Do not connect wires to any unused terminals.
- ③ When no POC switch is being used, place a jumper from L1 to X2-02.4 or set parameter 237 = 0.
- ④ When the LME7 isn't controlling the combustion air blower, wire the combustion air switch between X2-01.3 and X3-02.1. Be sure to remove X2-01.3 to N, and X3-02.1 to L1.
- ⑤ Add a jumper between X7-01.3 and X7-04.3 for direct spark ignition.
- ⑥ Wiring shown is for an SQM40... actuator. If using an SQM41... actuator, swap the wires going to terminals A and C on the potentiometer.

PME73.840A1 – Floating/bumping (position proportional) actuator control with valve proving; actuator can be disabled; ignition position = low fire

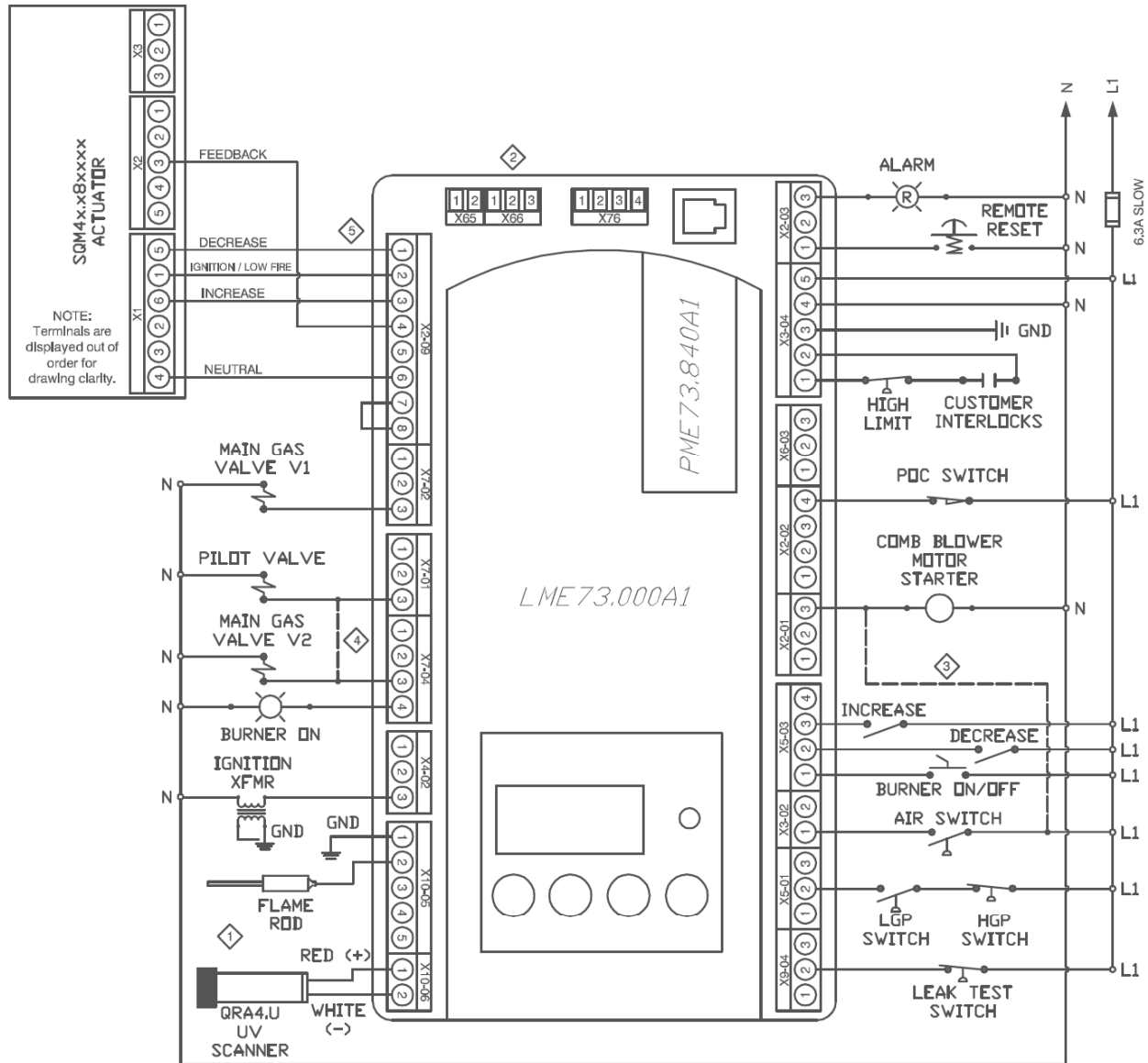

NOTES:

- ① Connect either a flame rod or UV scanner (QRA4.U), not both.
- ② Do not connect wires to any unused terminals.
- ③ When the LME7 isn't controlling the combustion air blower, wire the combustion air switch between X2-01.3 and X3-02.1. Be sure to remove X2-01.3 to N, and X3-02.1 to L1.
- ④ Add a jumper between X7-01.3 and X7-04.3 for direct spark ignition.
- ⑤ If no actuator is being used, jumper together terminals X2-09.1, X2-09.2, X2-09.3, and X2-09.4.

LME73 Parameter List

Parameter Number	Parameter Name	LEGEND - Password Level: S = Service; O = OEM; S/O = View - Service, Write - OEM; Info = Info Menu; Ser = Service Menu Shaded Parameters = Frequently Used				PME73. 811A1	PME73. 812A1	PME73. 840A1
		PW Level	Default	Range	Description			
000 Level: Parameter Backup / Restore / Change Passwords								
041	Service Level PW	O	7173	Any 4 characters	The service level password can be changed here. It must be exactly 4 characters in length. Enter the current password, then enter the new password twice to change it (c = current, n = new, r = repeat).	•	•	•
042	OEM Level PW		L7unI	Any 5 characters	The OEM level password can be changed here. It must be exactly 5 characters in length. Enter the current password, then enter the new password twice to change it (c = current, n = new, r = repeat).	•	•	•
060	Backup / Restore	S	Backup - 0 Restore - 0	0-1	Used to perform parameter backups and restores. Backup: Transfer LME7 parameters to PME7. Restore: Transfer PME7 parameters to LME7. Set parameter to 1 and press the info button to begin the backup or restore. Once a parameter backup is successful, the screen will display "bAC End". Once a parameter restore is successful, the screen will display "rSt End".	•	•	•
100 Level: General Information / Display Mode								
102	Production Date	Info	Read only		Date that the LME7 was produced in the DD.MM.YY format.	•	•	•
103	Serial Number				Serial number of the LME7.	•	•	•
113	Burner ID		Not set	0-99999999	The burner ID can be viewed through the AZL23 but can only be set using the ACS410 software. The burner ID must be all digits (no letters), from 1-8 digits in length. Typically the burner serial number is used. This serves as an identifier for the parameter set. The burner ID must be set in order to perform a parameter backup to a PC using the ACS410 software. Parameter backups to the PME7 program module can be made without setting the burner ID.	•	•	•
123	Min Load Change	S	2%	1-10%	This serves as a dead band for load changes to reduce small oscillations (hunting) by the actuator. If the requested change in fire rate is less than the setting of this parameter, the actuator will not move.	•	•	
140	Display Mode		1	1-4	Sets what will be displayed by the LME7 integral display. 1 = phase 2 = flame signal (QRA... flame scanner or flame rod) 3 = not used 4 = load	•	•	•
164	Startups	Info	Reset only		Displays the total number of startups. To reset this value, press and hold the info button until the value begins to flash, then let go. The value will automatically change to 0. Press the info button again to confirm the reset.	•	•	•
166	Total Startups				Displays the total number of startups. Not resettable.	•	•	•
170	Number of Relay Cycles		Read only		Displays the number of cycles on different internal relays in the LME7. Index 00 = K12 relay cycles Index 01 = K11 relay cycles Index 02 = K2 relay cycles Index 03 = K1 relay cycles	•	•	•
171	Max Relay Cycles				Displays the maximum number of relay cycles allowed on the internal relays of the LME7.	•	•	•

Parameter Number	Parameter Name	LEGEND - Password Level: S = Service; O = OEM; S/O = View - Service, Write - OEM; Info = Info Menu; Ser = Service Menu Shaded Parameters = Frequently Used				PME73. 811A1	PME73. 812A1	PME73. 840A1
		PW Level	Default	Range	Description			
200 Level: Burner Control								
212	Max Time Low Fire	S	58.212 sec	0-1237 sec	Sets the maximum time to let the LME7 drive the actuator to low fire before shutting the fuel valves after a call for heat has been removed from X5-03.1. This setting does not affect fuel valve closing time in the event of a safety shutdown.	•	•	
224	Time Air Pressure Switch	S/O	13.818 sec	0-13.818 sec	Once the LME7 reaches phase 22 for the second time (between phases 24 and 30), this sets the length of time the LME7 will wait for air pressure switch input X3-02.1 to become energized before a lockout occurs due to lack of air pressure. As soon as the switch is made, the sequence progresses.			•
225	Prepurge Time		29.106 sec	0-1237 sec	Sets the prepurge time (length of phase 30). The LME7 has a base prepurge time of 2.1 seconds. This setting adds seconds to the base time.	•	•	•
226	Pre-Ignition Time		6.174 sec	1.029-37.485 sec	The period of time that the ignition transformer (output X4-02.3) is energized before the pilot valves are opened. Sets the length of phase 38.			•
230	Pilot Stabilization Time		811 - 3.234 sec 812 - 3.234 sec 840 - 9.408 sec	3.234-74.97 sec	This setting defines the pilot stabilizing period if a pilot is used. During this period, only the pilot valve is open. The spark is de-energized. Sets the length of phase 44.	•	•	•
231	Pilot and Main Overlap Time		811 - 9.996 sec 812 - 9.996 sec 840 - 2.646 sec	0-74.97 sec	When a fuel train with a pilot is used, this setting defines the overlap of the pilot (output X7-01.3) and the main fuel valves. After this time expires, the pilot is de-energized. Sets the length of phase 50.	•	•	•
232	Main Stabilization Time		811 - 2.058 sec 812 - 2.058 sec 840 - 8.820 sec	2.058-74.97 sec	This setting defines the main stabilizing period if a pilot is used. During this period, only the main valve is open. The pilot valve is de-energized. "oP1" will be displayed during this time.	•	•	•
234	Postpurge Time		19.404 sec	0-1237 sec	Sets the postpurge time (length of phase 74).	•	•	•
237	POC Switch	S	1	0-2	This setting defines the function of POC switch input X2-02.4. 0 = deactivated 1 = activated (verify POC switch is closed on startup and shutdown) 2 = activated (verify POC switch is closed on startup and shutdown, and verify POC switch is open during main operation)	•	•	
239	Forced Intermittent	S/O	0	0-1	When activated, this forces the LME7 to shut the burner down every 24 hours of uninterrupted operation. The burner will automatically restart afterwards. The purpose of the shutdown is to check and cycle safety devices. 0 = deactivated 1 = activated	•	•	
240	Repetition Flame		This sets the numbers of times a flame failure must occur before causing a lockout. Most North American codes require 1 (no repetitions). 0 = no repetitions 1 = no repetitions 2 = 1 repetition 3 = 2 repetitions 4 = 3 repetitions	0	0-4	•	•	•

Parameter Number	Parameter Name	LEGEND - Password Level: S = Service; O = OEM; S/O = View - Service, Write - OEM; Info = Info Menu; Ser = Service Menu Shaded Parameters = Frequently Used				PME73. 811A1	PME73. 812A1	PME73. 840A1
		PW Level	Default	Range	Description			
241.00	Valve Proving Activation	S/O	1	0-1	This setting determines if gas valve proving (leak testing) will be performed. On PME73.811A1, gas valve proving is performed during shutdown unless the postpurge time (parameter 234) is set to 0. In that case, valve proving occurs during startup. On PME73.840A1, gas valve proving can be performed on startup, shutdown, or both depending on the settings of parameters 241.01 and 241.02. 0 = deactivated 1 = activated	•		•
241.01	Valve Proving Setup 1		1	0-1	Determines at which point during the burner's sequence that valve proving will be performed. Used in conjunction with parameter 241.02. 0 = valve proving on startup 1 = valve proving on shutdown			•
241.02	Valve Proving Setup 2		0	0-1	Determines at which point during the burner's sequence that valve proving will be performed. Used in conjunction with parameter 241.01. 0 = valve proving according to parameter 241.01 1 = valve proving on startup and shutdown			•
242	VP Evacuation Time		2.646 sec	0-2.646 sec	PME73.811A1: If valve proving is performed, this specifies the length of time that the downstream valve (V2) is energized (output X7-02.3). This will evacuate any gas that might exist between the gas valves. Sets the length of phase 80. PME73.840A1: If valve proving is performed, this specifies the length of time that the upstream valve (V1) is energized (output X7-04.4). This will fill the volume between the main gas valves to line pressure. Sets the length of phase 80.	•		•
243	VP Upstream Test		10.290 sec	1.029-37.485 sec	PME73.811A1: If valve proving is performed, this specifies the length of time that both the upstream and downstream valves are closed. If the pressure between the valves rises during this period (enough to open the NC valve proving pressure switch), then the upstream valve is leaking and the LME7 will lockout. A longer time period will produce a more sensitive test. Sets the length of phase 81. PME73.840A1: If valve proving is performed, this specifies the length of time that both the upstream and downstream valves are closed. If the pressure between the valves falls during this period (enough to close the NC valve proving pressure switch), then the downstream valve is leaking and the LME7 will lockout. A longer time period will produce a more sensitive test. Sets the length of phase 81.	•		•
244	VP Fill Time		2.646 sec	0-2.646 sec	PME73.811A1: If valve proving is performed, this specifies the length of time that the upstream valve (V1) is energized (output X7-04.4). This will fill the volume between the main gas valves to line pressure. Sets the length of phase 82. PME73.840A1: If valve proving is performed, this specifies the length of time that the downstream valve (V2) is energized (output X7-04.4). This will evacuate any gas that might exist between the gas valves. Sets the length of phase 82.	•		•
245	VP Downstream Test		10.290 sec	1.029-37.485 sec	PME73.811A1: If valve proving is performed, this specifies the length of time that both the upstream and downstream valves are closed. If the pressure between the valves falls during this period (enough to close the NC valve proving pressure switch), then the downstream valve is leaking and the LME7 will lockout. A longer time period will produce a more sensitive test. Sets the length of phase 83. PME73.840A1: If valve proving is performed, this specifies the length of time that both the upstream and downstream valves are closed. If the pressure between the valves rises during this period (enough to open the NC valve proving pressure switch), then the upstream valve is leaking and the LME7 will lockout. A longer time period will produce a more sensitive test. Sets the length of phase 83.	•		•

Parameter Number	Parameter Name	LEGEND - Password Level: S = Service; O = OEM; S/O = View - Service, Write - OEM; Info = Info Menu; Ser = Service Menu Shaded Parameters = Frequently Used				PME73. 811A1	PME73. 812A1	PME73. 840A1
		PW Level	Default	Range	Description			
247	Intermittent Pilot	S/O	0	0-1	Sets the type of pilot being used. If set to 1, the pilot valve will remain open from phase 40 to the end of main operation (oP...). 0 = interrupted pilot 1 = intermittent pilot	•	•	•
254	Flame Failure Response Time (FFRT)		1	0-1	Sets the flame failure response time (FFRT). The FFRT is the maximum length of time that the flame signal can go away before a lockout occurs. This setting also doubles as the length of time the signal from the air pressure switch can go away before a lockout occurs. On PME73.840A1, the FFRT is fixed at 1 second. 0 = 1 second 1 = 3 seconds	•	•	
257	Trial for Ignition		811 - 4.116 sec 812 - 4.116 sec 840 - 2.205 sec	0-13.23 sec	This setting defines the overlap of the spark (output X4-02.3) and the pilot valve (output X7-01.3) if a pilot is used. The LME7 has a base time of 0.3 seconds. This setting adds seconds to the base time. Sets the length of phase 40.	•	•	•
259	Actuator Opening Time		811 - 58.212 sec 812 - 58.212 sec 840 - 300.762 sec	0-1237 sec	Set slightly longer than the time it takes for the actuator to drive from fully closed to fully open.	•	•	•
260	Actuator Closing Time		811 - 58.212 sec 812 - 58.212 sec 840 - 300.762 sec	0-1237 sec	Set slightly longer than the time it takes for the actuator to drive from fully open to fully closed.	•	•	•
500 Level: Actuator Configuration (These parameters are found at the end of the 200 level parameters)								
515.00	Actuator Purge Position	S/O	1	0-1	Determines the position of the actuator during prepurge and postpurge. Note: This parameter is found at the end of the 200 level parameters. 0 = Purge at low fire 1 = Purge at high fire			•
515.01	Actuator Activation		1	0-1	Used to activate or deactivate the use of an actuator. Note: This parameter is found at the end of the 200 level parameters. 0 = deactivated (no actuator) 1 = activated (with actuator)			•
600 Level: Analog Input Configuration								
654	Analog Input	S	1	0-5	Sets the type of input signal being connected to terminal X65 or X5-03. This input signal is used to determine the actuator position during operation. 0 = 3-position 1 = 0-10 VDC 2 = 0-135 Ohm 3 = 0-20 mA 4 = 4-20 mA with lockout when input is less than 4 mA 5 = 4-20 mA without lockout when input is less than 4 mA	•	•	

Parameter Number	Parameter Name	LEGEND - Password Level: S = Service; O = OEM; S/O = View - Service, Write - OEM; Info = Info Menu; Ser = Service Menu Shaded Parameters = Frequently Used			PME73. 811A1	PME73. 812A1	PME73. 840A1
		PW Level	Default	Range			
700 Level: Fault History							
701-711	Fault History	Ser	Read only	Shows the current status (fault) along with the 10 most recent faults. 701 = current status, 702 = most recent fault, 703 = next most recent fault, etc. Each fault has indices that provide additional information about the fault: Index 00 = fault code Index 01 = start number Index 02 = phase Index 03 = load	•	•	•
900 Level: Operational Data							
920	Target Speed %	Ser	Read only	Not used on the LME73. Will always display as "-".	•	•	•
936	Actual Speed %			Not used on the LME73. Will always display as "-".	•	•	•
951	Incoming Voltage			Displays the real time mains voltage. Measured at terminal X3-04 pin 4 (neutral) and pin 5 (line).	•	•	•
954	Flame Signal			Displays the raw flame signal from 0-100% for any flame scanner type. A flame failure occurs when the flame signal drops below 20% for the time period specified by parameter 254. This signal refers to input terminal X10-06 (UV scanners) or input terminal X10-05.2 (flame rods).	•	•	•

LME73 Phase Diagrams

The Siemens LME7 burner controls can perform a number of different burner sequences based upon which PME7 program module is used, how certain parameters are set, and how the LME7 is wired.

Each program module has an associated phase diagram. The phase diagrams illustrate when input and output terminals are expected to be energized or de-energized. A legend on the bottom of each page describes the various symbols used in the diagrams.

Notes:

- 1) A jumper can be added between terminals X7-04.4 and X7-01.3 for direct spark ignition. If this jumper is added, pilot valve output X7-01.3 and main valve output X7-04.4 will be energized from phase 40 through the end of operation.
- 2) On PME73.811A1, if the LME7 is set to perform valve proving, valve proving will always take place during shutdown unless it is the next startup following a lockout or power loss, or if the postpurge time (parameter 234) is set to 0. In that case, valve proving occurs during startup and shutdown. When valve proving occurs during shutdown, it will happen at the same time as postpurge. Phases 80-83 will be displayed on the LME7 and the AZL23 even though postpurge (phase 74) is also occurring at the same time. The actual postpurge time will be at least the sum of all four valve proving time parameters (242, 243, 244, and 245). When valve proving occurs during startup, it will happen at the same time as prepurge. Phases 80-83 will be displayed on the LME7 and the AZL23 even though prepurge (phase 30) is also occurring at the same time. The actual prepurge time will be at least the sum of all four valve proving time parameters (242, 243, 244, and 245).
- 3) On PME73.840A1, if the LME7 is set to perform valve proving on startup, valve proving takes place at the same time as prepurge. Phases 80-83 will be displayed on the LME7 and the AZL23 even though prepurge (phase 30) is also occurring at the same time. The actual prepurge time will be at least the sum of all four valve proving time parameters (242, 243, 244, and 245).
- 4) On PME73.840A1, if the LME7 is set to perform valve proving on shutdown, valve proving takes place at the same time as postpurge. Phases 80-83 will be displayed on the LME7 and the AZL23 even though postpurge (phase 74) is also occurring at the same time. The actual postpurge time will be at least the sum of all four valve proving time parameters (242, 243, 244, and 245).

PME73.811A1 Phase Diagram

		Lockout	Standby, Waiting for Call for Heat	Test - Air Pressure Switch Open	Blower On	Drive to Prepurge Position	Test - Air Pressure Switch Closed	Prepurge (Note 2)	Drive to Ignition Position	Trial for Ignition	Flame Detection	Interval 1: Pilot Stabilization	Safety Time 2: Pilot and Main Overlap	Interval 2: Main Stabilization	Operation	Drive to Low Fire	Drive to Postpurge Position	Postpurge (Note 2)	Home Run	Evacuate	Atmospheric Test	Fill	Pressure Test	
		LOC	OFF	21	22	24	22	30	36	40	42	44	50	oP1	oP	oP1	72	74	10	80	81	82	83	
		Param.				259		225	260	257		230	231	232	240	212		234		242	243	244	245	
		STARTUP													OPERATION			SHUTDOWN			VALVE PROVING			
Terminal	Description	Notes	SAFETY TIME 1																					
INPUTS	X3-04.5	Main Voltage																						
	X3-04.1	Safety Loop	X	X																				
	X5-03.1	Burner On		M																				
	X3-02.1	Air Pressure Switch			X		M																	
	X5-01.2	Gas Pressure Switch(es)																						
	X9-04.2	Valve Proving Pressure Switch																					X	
	X10-05.2 X10-06.1/2	Flame Signal		X				X	X															
	X2-02.4	POC (P237 = 1) POC (P237 = 2)												X										
OUTPUTS	X2-02.3	POC Source	X	X																				
	X6-03.3	Safety Valve	X	X																				
	X2-01.3	Blower	X	X	X																			
	X4-02.3	Ignition Transformer		X	X	X	X	X	X	X		X	X	X	X	X	X	X	X	X	X	X	X	X
	X7-01.3	Pilot Valve	Note 1	X	X	X	X	X	X	X				X	X	X	X	X	X	X	X	X	X	X
	X7-04.4	Main Valve V1	Note 1	X	X	X	X	X	X	X	X	X	X					X	X	X	X	X	X	X
	X7-02.3	Main Valve V2		X	X	X	X	X	X	X	X	X	X					X	X	X	X	X	X	X
ACTUATOR	X2-03.3	Alarm		X	X	X	X	X	X	X	X	X	X	X	X	X	X	X	X	X	X	X	X	X
	X2-09.3	Drive to High Fire	X	X	X	X			X	X	X	X	X	X		X	X	X	X	X	X	X	X	
	X2-09.2	Drive to Ignition / Low Fire	X	X	X	X	X	X						X			X	X	X	X	X	X	X	
	X2-09.1	Drive Closed	X	X		X	X	X	X	X	X	X	X	X	X	X	X	X	X	X	X	X	X	X
X2-09.4	Position Feedback				M		M		M						M				M				M	

Legend : Energized X De-energized
 Energized or de-energized M Must be energized by end of phase

PME73.812A1 Phase Diagram





			Lockout	Standby, Waiting for Call for Heat	Test - Air Pressure Switch Open	Blower On	Drive to Prepurge Position Closed	Test - Air Pressure Switch Closed	Prepurge	Drive to Ignition Position	Trial for Ignition	Flame Detection	Interval 1: Pilot Stabilization	Safety Time 2: Pilot and Main Overlap	Interval 2: Main Stabilization	Operation	Drive to Low Fire	Drive to Postpurge Position	Postpurge	Home Run	
			Phase	LOC	OFF	21	22	24	22	30	36	40	42	44	50	oP1	oP	oP1	72	74	10
			Param.					259		225	260	257		230	231	232	240	212		234	
			STARTUP													OPERATION		SHUTDOWN			
			Terminal	Description	Notes								SAFETY TIME 1								
INPUTS	X3-04.5	Main Voltage																			
	X3-04.1	Safety Loop		X	X																
	X5-03.1	Burner On			M																
	X3-02.1	Air Pressure Switch				X			M												
	X5-01.2	Gas Pressure Switch(es)																			
	X10-05.2 X10-06.1/2	Flame Signal			X					X	X										
	X2-02.4	POC (P237 = 1) POC (P237 = 2)														X					
OUTPUTS	X2-02.3	POC Source		X	X																
	X6-03.3	Safety Valve		X	X																
	X2-01.3	Blower		X	X	X															
	X4-02.3	Ignition Transformer		X	X	X	X	X	X	X	X		X	X	X	X	X	X	X	X	X
	X7-01.3	Pilot Valve	Note 1	X	X	X	X	X	X	X	X					X	X	X	X	X	X
	X7-04.4	Main Valves	Note 1	X	X	X	X	X	X	X	X	X	X	X					X	X	X
	X2-03.3	Alarm			X	X	X	X	X	X	X	X	X	X	X	X	X	X	X	X	X
ACTUATOR	X2-09.3	Drive to High Fire		X	X	X	X			X	X	X	X	X	X		X	X	X	X	
	X2-09.2	Drive to Low Fire		X	X	X	X	X	X	X	X	X	X	X	X			X	X	X	
	X7-02.3	Drive to Ignition		X	X	X	X	X	X						X	X	X	X	X	X	
	X2-09.1	Drive Closed		X	X		X	X	X	X	X	X	X	X	X	X	X	X	X	X	
	X2-09.4	Position Feedback				M		M			M						M			M	

Legend : Energized De-energized
 Energized or de-energized Must be energized by end of phase

PME73.840A1 Phase Diagram

		Lockout	Standby, Waiting for Call for Heat	Test - Air Pressure Switch Open	Blower On	Drive to Prepurge Position Closed	Test - Air Pressure Switch Closed	Prepurge (Note 3)	Drive to Ignition Position	Preignition	Trial for Ignition	Flame Detection	Interval 1: Pilot Stabilization	Safety Time 2: Pilot and Main Overlap	Interval 2: Main Stabilization	Operation	Drive to Postpurge Position	Postpurge (Note 4)	Home Run	Pressure Test	Fill	Atmospheric Test	Evacuate		
		LOC	OFF	21	22	24	22	30	36	38	40	42	44	50	oP1	oP	72	74	10	80	81	82	83		
		Param.				259	224	225	260	226	257		230	231	232	240		234		242	243	244	245		
		STARTUP														OPERATION	SHUTDOWN				VALVE PROVING				
Terminal	Description	Notes															SAFETY TIME 1								
INPUTS	X3-04.5	Main Voltage																							
	X3-04.1	Safety Loop																							
	X5-03.1	Burner On		M																					
	X3-02.1	Air Pressure Switch			X		M																		
	X5-01.2	Gas Pressure Switch(es)																							
	X9-04.2	Valve Proving Pressure Switch																				X			
	X10-05.2 X10-06.1/2	Flame Signal		X				X	X																
	X2-02.4	POC																							
OUTPUTS	X2-02.3	POC Source	X	X																					
	X6-03.3	Safety Valve	X	X																					
	X2-01.3	Blower	X	X	X																		X		
	X4-02.3	Ignition Transformer	X	X	X	X	X	X	X	X			X	X	X	X	X	X	X	X	X	X	X		
	X7-01.3	Pilot Valve	Note 1	X	X	X	X	X	X	X	X					X	X	X	X	X	X	X	X		
	X7-02.3	Main Valve V1		X	X	X	X	X	X	X	X							X	X	X	X	X	X		
	X7-04.4	Main Valve V2	Note 1	X	X	X	X	X	X	X	X	X	X	X				X	X	X	X	X	X		
ACTUATOR	X2-03.3	Alarm		X	X	X	X	X	X	X	X	X	X	X	X	X	X	X	X	X	X	X	X		
	X2-09.3	Drive to High Fire	X	X	X	X		X	X	X	X	X	X	X	X			X	X	X	X	X	X		
	X2-09.2	Drive to Ignition / Low Fire	X	X	X	X	X	X							X			X	X	X	X	X	X		
	X2-09.1	Drive Closed	X	X		X	X	X	X	X	X	X	X	X	X	X	X	X	X	X	X	X	X		
X2-09.4	Position Feedback				M		M		M								M		M						

Legend :

	Energized		De-energized
	Energized or de-energized		Must be energized by end of phase

Section 1	Overview
Section 2	LME71 Wiring, Parameters, and Phase Diagrams
Section 3	LME73 Wiring, Parameters, and Phase Diagrams
Section 4	LME75 Wiring, Parameters, and Phase Diagrams
Section 5	Commissioning
Section 6	PWM Blowers
Section 7	Troubleshooting
Section 8	Modbus
Section 9	ACS410
Appendix A	Application Guide

Section 1	Overview
Section 2	LME71 Wiring, Parameters, and Phase Diagrams
Section 3	LME73 Wiring, Parameters, and Phase Diagrams
Section 4	LME75 Wiring, Parameters, and Phase Diagrams
Section 5	Commissioning
Section 6	PWM Blowers
Section 7	Troubleshooting
Section 8	Modbus
Section 9	ACS410
Appendix A	Application Guide

LME75 Wiring Diagrams

PME75.811A1 – Modulating actuator control with valve proving; self-check scanner or flame rod; ignition position = low fire

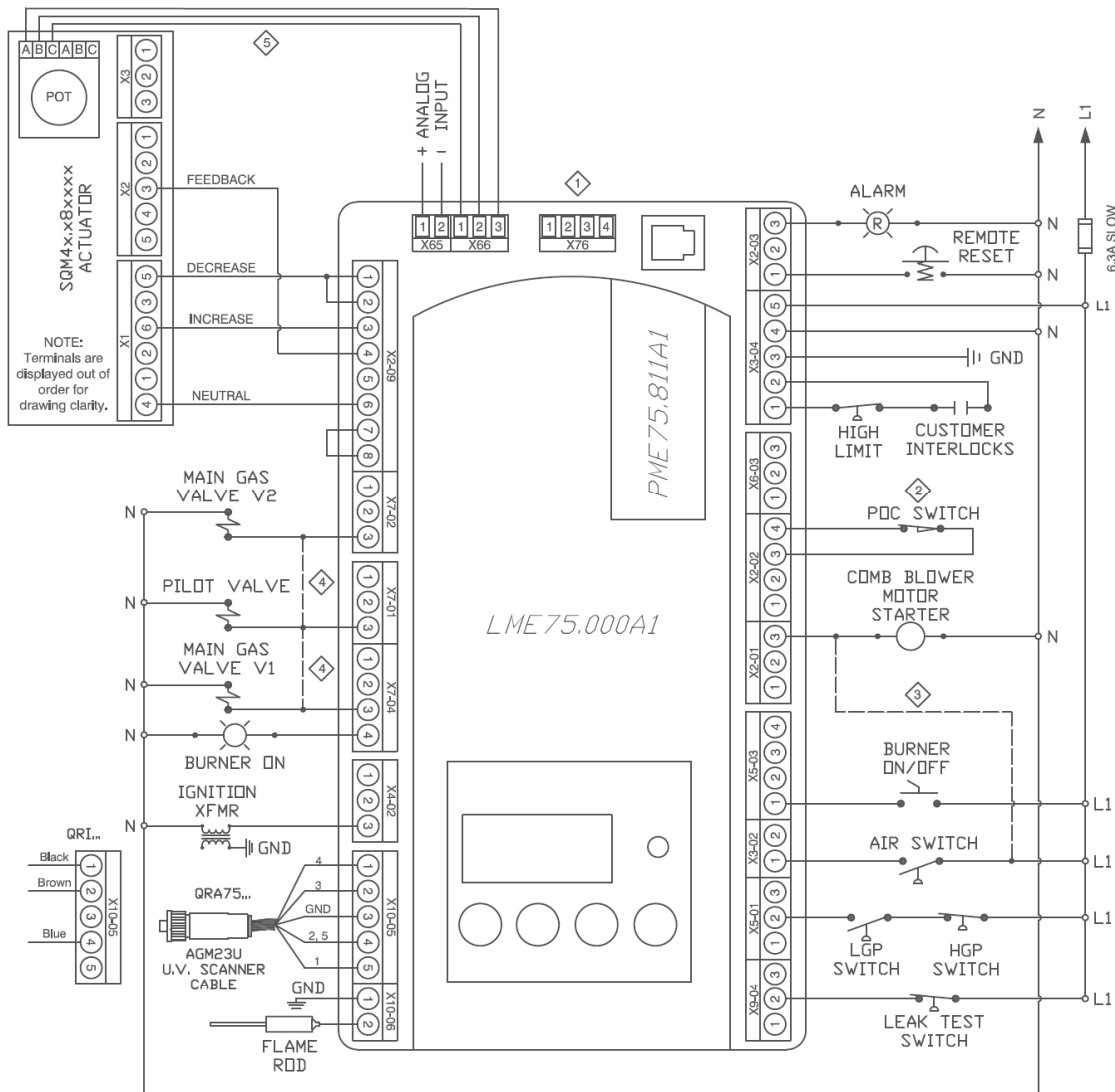

NOTES:

- ① Do not connect wires to any unused terminals.
- ② If no POC switch is being used, X2-02.4 can be used as a high gas pressure switch input (see parameter 237.01). When X2-02.4 is not being used at all, place a jumper from L1 to X2-02.4 or set parameter 237.00 = 0 and parameter 237.01 = 0.
- ③ When the LME7 isn't controlling the combustion air blower, wire the combustion air switch between X2-01.3 and X3-02.1. Be sure to remove X2-01.3 to N, and X3-02.1 to L1.
- ④ Add jumpers between X7-01.3 and X7-04.3 and between X7-01.3 and X7-02.3 for direct spark ignition. Valve proving is not possible with direct spark ignition.
- ⑤ Wiring shown is for an SQM40... actuator. If using an SQM41... actuator, swap the wires going to terminals A and C on the potentiometer.

PME75.812A1 - Modulating actuator control with independent ignition position; no valve proving; self-check scanner or flame rod

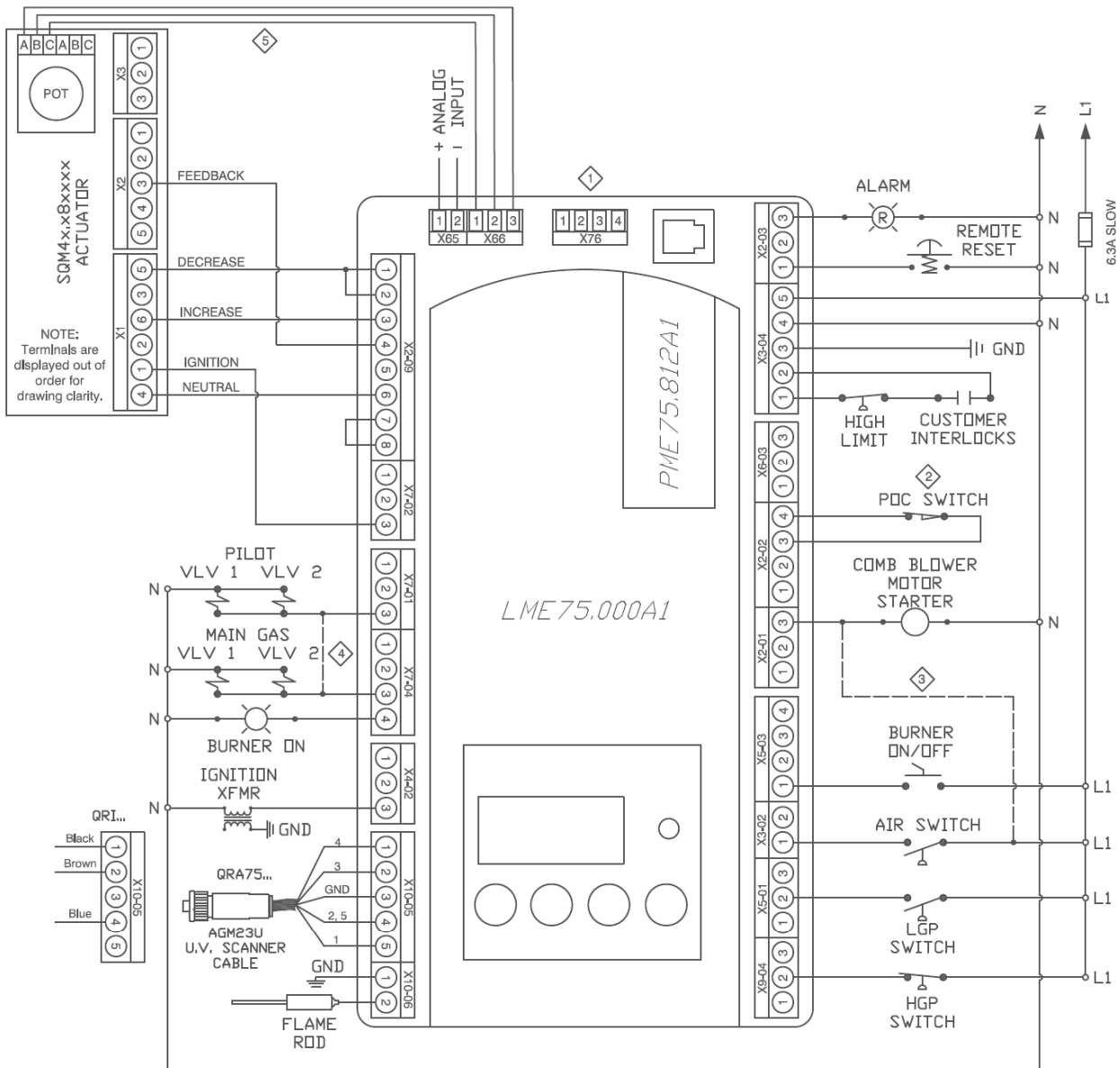

NOTES:

- ① Do not connect wires to any unused terminals.
- ② When no POC switch is being used, place a jumper from L1 to X2-02.4 or set parameter 237.00 = 0.
- ③ When the LME7 isn't controlling the combustion air blower, wire the combustion air switch between X2-01.3 and X3-02.1. Be sure to remove X2-01.3 to N, and X3-02.1 to L1.
- ④ Add a jumper between X7-01.3 and X7-04.3 for direct spark ignition.
- ⑤ Wiring shown is for an SQM40... actuator. If using an SQM41... actuator, swap the wires going to terminals A and C on the potentiometer.

LME75 Parameter List

Parameter Number	Parameter Name	LEGEND - Password Level: S = Service; O = OEM; S/O = View - Service, Write - OEM; Info = Info Menu; Ser = Service Menu Shaded Parameters = Frequently Used				PME75. 811A1	PME75. 812A1
		PW Level	Default	Range	Description		
000 Level: Parameter Backup / Restore / Change Passwords							
041	Service Level PW	O	7576	Any 4 characters	The service level password can be changed here. It must be exactly 4 characters in length. Enter the current password, then enter the new password twice to change it (c = current, n = new, r = repeat).	•	•
042	OEM Level PW		L7unI	Any 5 characters	The OEM level password can be changed here. It must be exactly 5 characters in length. Enter the current password, then enter the new password twice to change it (c = current, n = new, r = repeat).	•	•
060	Backup / Restore	S	Backup - 0 Restore - 0	0-1	Used to perform parameter backups and restores. Backup: Transfer LME7 parameters to PME7. Restore: Transfer PME7 parameters to LME7. Set parameter to 1 and press the info button to begin the backup or restore. Once a parameter backup is successful, the screen will display "bAC End". Once a parameter restore is successful, the screen will display "rSt End".	•	•
100 Level: General Information / Display Mode							
102	Production Date	Info	Read only		Date that the LME7 was produced in the DD.MM.YY format.	•	•
103	Serial Number		Read only		Serial number of the LME7.	•	•
113	Burner ID		Not set	0-99999999	The burner ID can be viewed through the AZL23 but can only be set using the ACS410 software. The burner ID must be all digits (no letters), from 1-8 digits in length. Typically the burner serial number is used. This serves as an identifier for the parameter set. The burner ID must be set in order to perform a parameter backup to a PC using the ACS410 software. Parameter backups to the PME7 program module can be made without setting the burner ID.	•	•
123	Min Load Change	S	2%	1-10%	This serves as a dead band for load changes to reduce small oscillations (hunting) by the actuator. If the requested change in fire rate is less than the setting of this parameter, the actuator will not move.	•	•
140	Display Mode		1	1-4	Sets what will be displayed by the LME7 integral display. 1 = phase 2 = flame signal (flame rod) 3 = flame signal (QRA75... or QRI... flame scanner) 4 = load	•	•
164	Startups	Info	Reset only		Displays the total number of startups. To reset this value, press and hold the info button until the value begins to flash, then let go. The value will automatically change to 0. Press the info button again to confirm the reset.	•	•
166	Total Startups		Read only		Displays the total number of startups. Not resettable.	•	•
170	Number of Relay Cycles		Read only		Displays the number of cycles on different internal relays in the LME7. Index 00 = K8 relay cycles Index 01 = K7 relay cycles Index 02 = K2 relay cycles Index 03 = K1 relay cycles	•	•
171	Max Relay Cycles		Read only		Displays the maximum number of relay cycles allowed on the internal relays of the LME7.	•	•

Parameter Number	Parameter Name	LEGEND - Password Level: S = Service; O = OEM; S/O = View - Service, Write - OEM; Info = Info Menu; Ser = Service Menu Shaded Parameters = Frequently Used				PME75. 811A1	PME75. 812A1
		PW Level	Default	Range	Description		
179	Two Flame Sensor Logic	S/O	0	0-1	The LME75 allows the use of two flame sensors at the same time (one flame rod and one flame scanner). This sets the logic for the flame sensor inputs. 0 = OR logic - a valid flame signal must be present on one of the two flame signal inputs. This applies from the end of phase 42 through the end of burner operation. 1 = AND logic - a valid flame signal must be present on both flame signal inputs. This only applies from the start of phase 52 through the end of operation. During phases 42-50, only one flame signal must be present.	•	•
180	Self-Check Time		0	0-1	Sets the time interval for the test of the self-check scanner. On the QRA75... scanner, this sets the length of time between shutter operations. 0 = every 5 minutes 1 = every 5 seconds	•	•
200 Level: Burner Control							
212	Max Time Low Fire	S	58.212 sec	0-1237 sec	Sets the maximum time to let the LME7 drive the actuator to low fire before shutting the fuel valves after a call for heat has been removed from X5-03.1. This setting does not affect fuel valve closing time in the event of a safety shutdown.	•	•
216	Extraneous Light Tolerance Time		29.106 sec	0-1237 sec	This sets the amount of time that a flame signal must be present in standby before the LME7 goes into lockout (Loc 4). When a flame signal is present during standby, the LME7 immediately goes to Phase 04. If the flame signal goes away before this time elapses, the LME7 will switch from Phase 04 back to standby (OFF) without requiring a manual reset.	•	•
217.00	Flame On Response Time		Read only		Sets the amount of time that a flame signal must be present before the LME7 considers that flame signal to be valid. This parameter has no effect as the value is set to 0 seconds.	•	•
217.01	Flame Failure Response Time (FFRT)	S/O	1.911 sec	0-13.818 sec	Sets the flame failure response time (FFRT). The FFRT is the maximum length of time that the flame signal can go away before a lockout occurs. The LME75 has a base flame failure response time of 1 second. This setting adds time to the base time. For example, the default setting of 1.911 seconds means the FFRT is 2.911 seconds.	•	•
218	Forced Intermittent Time		80050.31 sec	0-80050.31 sec	Sets the length of time before a forced burner shutdown occurs. If the burner has been running uninterrupted for this length of time, and parameter 239 is set to 1, the burner will shut down and automatically restart afterwards. The purpose of the shutdown is to check and cycle safety devices.	•	•
222	Prepurge Activation	S	1	0-1	Activates or deactivates prepurge after a normal shutdown. If this is set to 0, a prepurge will still occur on the next startup following a lockout or a loss of power, or if valve proving is activated and occurs during startup. 0 = deactivated 1 = activated	•	•
223	Low Gas Pressure Shutdown Behavior		1	0-1	Sets the behavior of the LME7 in the event that the low gas pressure switch connected to input X5-01.2 is de-energized. 0 = safety shutdown and start prevention - the burner is shutdown and the LME7 goes into Phase 90 until gas pressure is restored. Once gas pressure is restored, the burner will start back up automatically. 1 = lockout (Loc 20)	•	•

Parameter Number	Parameter Name	LEGEND - Password Level: S = Service; O = OEM; S/O = View - Service, Write - OEM; Info = Info Menu; Ser = Service Menu Shaded Parameters = Frequently Used				PME75.811A1	PME75.812A1
		PW Level	Default	Range	Description		
224	Time Air Pressure Switch	S/O	13.818 sec	0-13.818 sec	Once the LME7 reaches phase 22 for the second time (between phases 24 and 30), this sets the length of time the LME7 will wait for air pressure switch input X3-02.1 to become energized before a lockout occurs due to lack of air pressure. As soon as the switch is made, the sequence progresses.	•	•
225.00	Prepurge Time		29.106 sec	0-1237 sec	Sets the prepurge time (length of phase 30) along with parameter 225.01.	•	•
225.01	Prepurge Multiplier		1	1-255	Sets a multiplier for the prepurge time. The actual prepurge time (length of phase 30) is determined by multiplying parameter 225.00 and this parameter.	•	•
230	Pilot Stabilization Time		3.234 sec	0-74.97 sec	This setting defines the pilot stabilizing period if a pilot is used. During this period, only the pilot valve is open. The spark is de-energized. Sets the length of phase 44.	•	•
231	Pilot and Main Overlap Time		9.996 sec	0-74.97 sec	When a fuel train with a pilot is used, this setting defines the overlap of the pilot (output X7-01.3) and the main fuel valves. After this time expires, the pilot is de-energized. Sets the length of phase 50.	•	•
232	Main Stabilization Time		2.058 sec	2.058-74.97 sec	This setting defines the main stabilizing period if a pilot is used. During this period, only the main valve is open. The pilot valve is de-energized. Sets the length of phase 52.	•	•
234.00	Postpurge Time	S	19.404 sec	0-1237 sec	Sets the postpurge time (length of phase 74) along with parameter 234.01.	•	•
234.01	Postpurge Multiplier		1	1-255	Sets a multiplier for the postpurge time. The actual postpurge time (length of phase 74) is determined by multiplying parameter 234.00 and this parameter.	•	•
235.00	Air Pressure Switch Evaluation		1	0-1	Sets the behavior of the air pressure switch input X3-02.1. 0 = Air pressure switch is not evaluated during operation (lack of air pressure has no effect) 1 = Air pressure switch is evaluated during operation (lack of air pressure causes a lockout)	•	•
235.01	Response Time Air Pressure Switch		0.294 sec	0-2.058 sec	Sets the amount of time that the air pressure switch input X3-02.1 can be de-energized before a lockout occurs. The LME7 has a base time of 0.7 seconds. This setting adds time to the base time.	•	•
236	Low Gas Pressure Evaluation		0	0-1	Sets the behavior of the low gas pressure switch input X5-01.2. 0 = Low gas pressure switch is evaluated during startup and operation (phases 30-70). 1 = Low gas pressure switch is only evaluated when main fuel valves are open (phases 52-70). This is useful when the low gas pressure switch is mounted downstream of the main fuel valves for CSA B149.3 compliance.	•	•
237.00	POC Switch		1	0-2	This setting defines the function of POC switch input X2-02.4. 0 = deactivated 1 = activated (verify POC switch is closed on startup and shutdown) 2 = activated (verify POC switch is closed on startup and shutdown, and verify POC switch is open during main operation)	•	•
237.01	High Gas Pressure Switch	S/O	0	0-1	PME75.811A1: Sets the function of input X2-02.4. 0 = POC 1 = high gas pressure switch PME75.812A1: Activates or deactivates input X9-04.2 for use with a high gas pressure switch. 0 = deactivated 1 = activated	•	•

Parameter Number	Parameter Name	LEGEND - Password Level: S = Service; O = OEM; S/O = View - Service, Write - OEM; Info = Info Menu; Ser = Service Menu Shaded Parameters = Frequently Used				PME75. 811A1	PME75. 812A1
		PW Level	Default	Range	Description		
239	Forced Intermittent	S/O	0	0-1	When activated, this forces the LME7 to shut the burner down after a predetermined length of uninterrupted operation. This length of time is set by parameter 218. The burner will automatically restart afterwards. The purpose of the shutdown is to check and cycle safety devices. 0 = deactivated 1 = activated	•	•
240	Repetition Flame	S	0	0-4	This sets the numbers of times a flame failure must occur before causing a lockout. Most North American codes require 1 (no repetitions). 0 = no repetitions 1 = no repetitions 2 = 1 repetition 3 = 2 repetitions 4 = 3 repetitions	•	•
241	Valve Proving Activation		1	0-1	This setting determines if gas valve proving (leak testing) will be performed. Gas valve proving is performed during shutdown unless the postpurge time (parameter 234.00) is set to 0. In that case, valve proving occurs during startup. 0 = deactivated 1 = activated	•	
242	VP Evacuation Time		2.646 sec	0-2.646 sec	If valve proving is performed, this specifies the length of time that the downstream valve (V2) is energized (output X7-01.3). This will evacuate any gas that might exist between the gas valves. Sets the length of phase 80.	•	
243	VP Upstream Test		10.290 sec	1.029-37.485 sec	If valve proving is performed, this specifies the length of time that both the upstream and downstream valves are closed. If the pressure between the valves rises during this period (enough to open the NC valve proving pressure switch), then the upstream valve is leaking and the LME7 will lockout. A longer time period will produce a more sensitive test. Sets the length of phase 81.	•	
244	VP Fill Time		2.646 sec	0-2.646 sec	If valve proving is performed, this specifies the length of time that the upstream valve (V1) is energized (output X7-04.4). This will fill the volume between the main gas valves to line pressure. Sets the length of phase 82.	•	
245	VP Downstream Test		10.290 sec	1.029-37.485 sec	If valve proving is performed, this specifies the length of time that both the upstream and downstream valves are closed. If the pressure between the valves falls during this period (enough to close the NC valve proving pressure switch), then the downstream valve is leaking and the LME7 will lockout. A longer time period will produce a more sensitive test. Sets the length of phase 83.	•	
247	Intermittent Pilot		S/O	0	0-1	Sets the type of pilot being used. If set to 1, the pilot valve will remain open from phase 40 to the end of main operation (oP...). 0 = interrupted pilot 1 = intermittent pilot	•
257	Trial for Ignition	S/O	4.116 sec	0-13.23 sec	This setting defines the overlap of the spark (output X4-02.3) and the pilot valve (output X7-01.3) if a pilot is used. The LME7 has a base time of 0.3 seconds. This setting adds seconds to the base time. Sets the length of phase 40.	•	•
259	Actuator Opening Time		58.212 sec	0-1237 sec	Set slightly longer than the time it takes for the actuator to drive from fully closed to fully open.	•	•
260	Actuator Closing Time		58.212 sec	0-1237 sec	Set slightly longer than the time it takes for the actuator to drive from fully open to fully closed.	•	•

Parameter Number	Parameter Name	LEGEND - Password Level: S = Service; O = OEM; S/O = View - Service, Write - OEM; Info = Info Menu; Ser = Service Menu Shaded Parameters = Frequently Used				PME75. 811A1	PME75. 812A1
		PW Level	Default	Range	Description		
500 Level: Actuator Configuration							
515.00	Actuator Purge Position	S	Read only		Determines the position of the actuator during prepurge and postpurge. Cannot be changed on the LME75. The actuator will always purge at high fire.	•	•
515.01	Actuator Activation	S/O	1	0-1	Used to activate or deactivate the use of an actuator. If set to 0, parameter 560 must also be set to 0. 0 = deactivated (no actuator) 1 = activated (with actuator)	•	•
560	Analog Input Type	S	2	0-2	Sets the type of input being used to control the actuator. 0 = no actuator / 3-position input 1 = not used 2 = analog input	•	•
600 Level: Analog Input Configuration							
654	Analog Input Signal	S	1	0-5	Sets the type of input signal being connected to terminal X65 or X5-03 when parameter 560 is set to 2. This input signal is used to determine the actuator position during operation. 0 = 3-position 1 = 0-10 VDC 2 = 0-135 Ohm 3 = 0-20 mA 4 = 4-20 mA with lockout when input is less than 4 mA 5 = 4-20 mA without lockout when input is less than 4 mA	•	•
700 Level: Fault History							
701-711	Fault History	Ser	Read only		Shows the current status (fault) along with the 10 most recent faults. 701 = current status, 702 = most recent fault, 703 = next most recent fault, etc. Each fault has indices that provide additional information about the fault: Index 00 = fault code Index 01 = start number Index 02 = phase Index 03 = load	•	•
900 Level: Operational Data							
920	Target Speed %	Ser	Read only		Not used on the LME75. Will always display as a "-".	•	•
935	Actual Speed RPM				Not used on the LME75. Will always display as a "-".	•	•
936	Actual Speed %				Not used on the LME75. Will always display as a "-".	•	•
951	Incoming Voltage				Displays the real time mains voltage. Measured at terminal X3-04 pin 4 (neutral) and pin 5 (line).	•	•
954	Flame Signal				Displays the raw flame signal from 0-100% for any flame scanner type. A flame failure occurs when the flame signal drops below 20% for the time period specified by parameter 217.01. Index 00 = flame rod (input X10-06.2) Index 01 = flame scanner QRA75/QRI (input X10-05.1)	•	•

LME75 Phase Diagrams

The Siemens LME7 burner controls can perform a number of different burner sequences based upon which PME7 program module is used, how certain parameters are set, and how the LME7 is wired.

Each program module has an associated phase diagram. The phase diagrams illustrate when input and output terminals are expected to be energized or de-energized. A legend on the bottom of each page describes the various symbols used in the diagrams.

Notes:

- 1) A jumper can be added between terminals X7-04.4 and X7-01.3 for direct spark ignition. If this jumper is added, pilot valve output X7-01.3 and main valve output X7-04.4 will be energized from phase 40 through the end of phase 70.
- 2) On PME75.811A1, if the LME7 is set to perform valve proving, valve proving will always take place during shutdown unless it is the next startup following a lockout or power loss, or if the postpurge time (parameter 234.00) is set to 0. In that case, valve proving occurs during startup and shutdown. When valve proving occurs during shutdown, it will happen at the same time as postpurge. Phases 80-83 will be displayed on the LME7 and the AZL23 even though postpurge (phase 74) is also occurring at the same time. The actual postpurge time will be at least the sum of all four valve proving time parameters (242, 243, 244, and 245). When valve proving occurs during startup, it will happen at the same time as prepurge. Phases 80-83 will be displayed on the LME7 and the AZL23 even though prepurge (phase 30) is also occurring at the same time. The actual prepurge time will be at least the sum of all four valve proving time parameters (242, 243, 244, and 245).
- 3) If parameter 235.00 is set to 0, air pressure switch input X3-02.1 only needs to be energized during phases 22 through 52 and during phase 74. The switch is not checked during main burner operation.
- 4) If parameter 236 is set to 1, low gas pressure switch input X5-01.2 only needs to be energized during phases 52 through 70. The input is not checked before the main valves are open. This is useful for applications where the low gas pressure switch is mounted downstream of the safety shutoff valves (for CSA B149.3 compliance).

PME75.811A1 Phase Diagram

	Terminal	Description	Notes	Lockout	Standby, Waiting for Call for Heat	Test - Air Pressure Switch Open	Blower On	Drive to Prepurge Position	Test - Air Pressure Switch Closed	Prepurge (Note 2)	Drive to Ignition Position	Trial for Ignition	Flame Detection	Interval 1: Pilot Stabilization	Safety Time 2: Pilot and Main Overlap	Interval 2: Main Stabilization	Operation	Drive to Low Fire	Shutdown	Drive to Postpurge Position	Postpurge (Note 2)	Home Run	Evacuate	Atmospheric Test	Fill	Pressure Test		
				LOC	OFF	21	22	24	22	30	36	40	42	44	50	52	oP	oP1	70	72	74	10	80	81	82	83		
Param.								259		225	260	257		230	231	232	240	212			234		242	243	244	245		
STARTUP																	OPERATION			SHUTDOWN			VALVE PROVING					
SAFETY TIME 1																												
INPUTS	X3-04.5	Main Voltage																										
	X3-04.1	Safety Loop		X	X																							
	X5-03.1	Burner On			M																							
	X3-02.1	Air Pressure Switch	Note 3			X			M																			
	X5-01.2	Gas Pressure Switch(es)	Note 4																									
	X9-04.2	Valve Proving Pressure Switch																										
	X10-05.1	Flame Signal			X					X	X																	
	X10-06.2																											
OUTPUTS	X2-02.4	POC (P237.00 = 1, P237.01 = 0)																										
		POC (P237.00 = 2, P237.01 = 0)													X													
		High Gas Press. Sw. (P237.01 = 1)																										
	X2-02.3	POC Source		X	X																							
	X6-03.3	Safety Valve		X	X																							
	X2-01.3	Blower		X	X	X																						
	X4-02.3	Ignition Transformer		X	X	X	X	X	X	X	X			X	X	X	X	X	X	X	X	X	X	X	X	X	X	X
X7-01.3	Pilot Valve	Note 1	X	X	X	X	X	X	X	X						X	X	X	X	X	X	X	X	X	X	X	X	
X7-04.4	Main Valve V1	Note 1	X	X	X	X	X	X	X	X	X	X	X								X	X	X			X		
X7-02.3	Main Valve V2		X	X	X	X	X	X	X	X	X	X	X								X	X	X			X		
X2-03.3	Alarm			X	X	X	X	X	X	X	X	X	X	X	X	X	X	X	X	X	X	X	X	X	X	X	X	
ACTUATOR	X2-09.3	Drive to High Fire		X	X	X	X				X	X	X	X	X	X		X	X	X	X	X	X	X	X	X	X	
	X2-09.2	Drive to Ignition / Low Fire		X	X	X	X	X	X							X			X	X	X	X	X	X	X	X	X	
	X2-09.1	Drive Closed		X	X		X	X	X	X	X	X	X	X	X	X		X	X	X	X	X					X	
	X2-09.4	Position Feedback				M		M			M							M									M	

Legend : Energized X De-energized
 Energized or de-energized M Must be energized by end of phase

PME75.812A1 Phase Diagram

				Lockout	Standby, Waiting for Call for Heat	Test - Air Pressure Switch Open	Blower On	Drive to Prepurge Position	Test - Air Pressure Switch Closed	Prepurge	Drive to Ignition Position	Trial for Ignition	Flame Detection	Interval 1: Pilot Stabilization	Safety Time 2: Pilot and Main Overlap	Interval 2: Main Stabilization	Operation	Drive to Low Fire	Shutdown	Drive to Postpurge Position	Postpurge	Home Run
Phase	LOC	OFF	21	22	24	22	30	36	40	42	44	50	52	oP	oP1	70	72	74	10			
Param.					259		225	260	257		230	231	232	240	212			234				
	STARTUP															OPERATION			SHUTDOWN			
Terminal	Description	Notes																				
INPUTS	X3-04.5	Main Voltage																				
	X3-04.1	Safety Loop		X	X																	
	X5-03.1	Burner On			M																	
	X3-02.1	Air Pressure Switch	Note 3			X			M													
	X5-01.2	Gas Pressure Switch(es)	Note 4																			
	X10-05.1 X10-06.2	Flame Signal			X					X	X											
	X9-04.2	High Gas Pressure Switch																				
	X2-02.4	POC (P237.00 = 1) POC (P237.00 = 2)														X						
OUTPUTS	X2-02.3	POC Source		X	X																	
	X6-03.3	Safety Valve		X	X																	
	X2-01.3	Blower		X	X	X																
	X4-02.3	Ignition Transformer		X	X	X	X	X	X	X	X		X	X	X	X	X	X	X	X	X	X
	X7-01.3	Pilot Valve	Note 1	X	X	X	X	X	X	X	X					X	X	X	X	X	X	X
	X7-04.4	Main Valves	Note 1	X	X	X	X	X	X	X	X	X	X	X						X	X	X
	X2-03.3	Alarm			X	X	X	X	X	X	X	X	X	X	X	X	X	X	X	X	X	X
ACTUATOR	X2-09.3	Drive to High Fire		X	X	X	X			X	X	X	X	X	X	X		X	X	X	X	X
	X2-09.2	Drive to Low Fire		X	X	X	X	X	X	X	X	X	X	X	X	X			X	X	X	X
	X7-02.3	Drive to Ignition		X	X	X	X	X	X							X	X	X	X	X	X	X
	X2-09.1	Drive Closed		X	X		X	X	X	X	X	X	X	X	X	X	X	X	X	X	X	
	X2-09.4	Position Feedback				M		M			M							M				M

Legend : Energized De-energized
 Energized or de-energized Must be energized by end of phase

Section 1	Overview
Section 2	LME71 Wiring, Parameters, and Phase Diagrams
Section 3	LME73 Wiring, Parameters, and Phase Diagrams
Section 4	LME75 Wiring, Parameters, and Phase Diagrams
Section 5	Commissioning
Section 6	PWM Blowers
Section 7	Troubleshooting
Section 8	Modbus
Section 9	ACS410
Appendix A	Application Guide

Section 1	Overview
Section 2	LME71 Wiring, Parameters, and Phase Diagrams
Section 3	LME73 Wiring, Parameters, and Phase Diagrams
Section 4	LME75 Wiring, Parameters, and Phase Diagrams
Section 5	Commissioning
Section 6	PWM Blowers
Section 7	Troubleshooting
Section 8	Modbus
Section 9	ACS410
Appendix A	Application Guide

Commissioning a New LME7 Burner Control

1. Ensure all devices are properly connected to the LME7. See Section 2 (LME71...), Section 3 (LME73...), or Section 4 (LME75...) of this manual for more information on wiring devices to the LME7 burner control.
2. Install the PME7 program module into the LME7 burner control. Apply power to the LME7.
3. The LME7 will alternately display “rSt” and “PrC”, indicating that the parameter set from the PME7 program module needs to be restored into the LME7 burner control. To do so, press and hold the info button on the LME7 burner control until the LED on the LME7 turns yellow, then release. This should take approximately three seconds.
4. The word “run” will briefly be displayed. Then, the display will alternate between “rSt” and “End”. This indicates that the restore process was successful.
5. Press and hold the info button for approximately two seconds to reset the LME7. If everything was done properly, the LME7 should now display “OFF”.
6. If any LME7 parameters need to be changed from their default values, an AZL23 display unit is required. Plug in the AZL23 display unit.
7. To log in to the LME7 and access the parameters, press and hold the F and A buttons simultaneously on the AZL23 until the word “CodE” appears.
8. Enter the password for the desired access level. The default passwords are:

LME71... / LME73... Service Level Password – 7173
LME75... Service Level Password – 7576
LME7... OEM Level Password – L7unI
9. Set all parameters as necessary for the application. See Section 2 (LME71...), Section 3 (LME73...), or Section 4 (LME75...) of this manual for more information on setting the parameters in the LME7 burner control.
10. If using an LME73... or LME75... burner control with an actuator, the limit switches on the actuator must be set. The most common actuator used with the LME7 is the SQM4x.x8xxxx. On the SQM4x.x8xxxx actuator, set the red cam (I) for the desired high fire position. Set the blue cam (II) for the desired low fire position. If using PME73.812A1 or PME75.812A1, which allow for an independent ignition position, set the orange cam (III) for the desired ignition position. If using an actuator other than the SQM4x.x8xxxx, see the actuator literature for more information on setting the limit switches.
11. At this point, the LME7 burner control is fully commissioned. It is recommended to perform a parameter backup to synchronize the parameter settings of the LME7 burner control and PME7 program module. See the next section for instructions on performing a parameter backup.

Parameter Backups / Restores

Both the LME7 burner control and PME7 program module contain one parameter set. The parameter set in the LME7 burner control is always the one that is used for burner operation. The parameter set in the PME7 program module is simply a backup parameter set. At any time, these two parameter sets can be synchronized with a parameter backup or a parameter restore.

Parameter backup – Overwriting the PME7 parameter set with the LME7 parameter set

Parameter restore – Overwriting the LME7 parameter set with the PME7 parameter set

The following procedures can be used to perform parameter backups or parameter restores.

Parameter Backup (LME7 -> PME7) Using the LME7 Built-in Display

1. Press and hold the + and - buttons on the LME7 together for approximately one second. “PrC” will be displayed briefly, then the display will show “rSt”.
2. Press the + or - button to toggle to “bAC”.
3. Press and hold the info button until the word “run” is displayed, then release.
4. The LME7 will alternately display “bAC” and “End” once the parameter backup is complete.
5. Press the info button to return to the normal display.

Parameter Restore (PME7 -> LME7) Using the LME7 Built-in Display

Use to overwrite the parameters in the LME7 with those previously saved in the PME7.

1. Press and hold the + and - buttons on the LME7 together for approximately one second. “PrC” will be displayed briefly, then the display will show “rSt”.
2. Press and hold the info button until the word “run” is displayed, then release.
3. The LME7 will alternately display “rSt” and “End” once the parameter restore is complete.
4. Press the info button to return to the normal display.

Parameter Backup (LME7 -> PME7) Using the AZL23 Display Unit

1. Press and hold the F and A buttons on the AZL23 until “CodE” is displayed, then release.
2. Log in at the service or OEM level.
3. The display will show “000: Int”. Press the info button on the AZL23.
4. Toggle to parameter 060 using the + and - buttons, then press the info button.
5. Press the + or - button to toggle to “bAC_UP”, then press the info button.
6. Tap the + button twice to change the value to 1, then press the info button.
7. The word “run” will be displayed during the backup process.
8. The AZL23 will display “bAC End” once the parameter backup is complete.
9. Press the info button to return to the normal display.

Parameter Restore (PME7 -> LME7) Using the AZL23 Display Unit

Use to overwrite the parameters in the LME7 with those previously saved in the PME7.

1. Press and hold the F and A buttons on the AZL23 until "CodE" is displayed, then release.
2. Log in at the service or OEM level.
3. The display will show "000: Int". Press the info button on the AZL23.
4. Toggle to parameter 060 using the + and - buttons, then press the info button.
5. "rEStorE" will be displayed. Press the info button.
6. Tap the + button twice to change the value to 1, then press the info button.
7. The word "run" will be displayed during the restore process.
8. The AZL23 will display "rSt End" once the parameter restore is complete.
9. Press the info button to return to the normal display.

Displaying the Flame Signal from the LME7 Burner Control

The flame signal can be viewed on the LME7 burner control using the following procedures.

LME71.../LME73... Burner Control

1. Press and hold the + button on the LME7 burner control. "FL1" will be displayed briefly, followed by the flame signal from 0-100%.
2. Holding the + button for less than three seconds will briefly display the flame signal. Upon releasing the + button, the display will return to normal.
3. Holding the + button for more than three seconds will leave the flame signal displayed for two minutes. This is indicated by the point after the flame signal value flashing. After two minutes, or after pressing the + and - buttons together (escape), the display will return to normal.

LME75... Burner Control with a QRA75... or QRI... Flame Scanner

1. Press and hold the - button on the LME7 burner control. "FL2" will be displayed briefly, followed by the flame signal from 0-100%.
2. Holding the - button for less than three seconds will briefly display the flame signal. Upon releasing the - button, the display will return to normal.
3. Holding the - button for more than three seconds will leave the flame signal displayed for two minutes. This is indicated by the point after the flame signal value flashing. After two minutes, or after pressing the + and - buttons together (escape), the display will return to normal.

LME75... Burner Control with a Flame Rod

1. Press and hold the + button on the LME7 burner control. "FL1" will be displayed briefly, followed by the flame signal from 0-100%.
2. Holding the + button for less than three seconds will briefly display the flame signal. Upon releasing the + button, the display will return to normal.
3. Holding the + button for more than three seconds will leave the flame signal displayed for two minutes. This is indicated by the point after the flame signal value flashing. After two minutes, or after pressing the + and - buttons together (escape), the display will return to normal.

Displaying the Actuator Position / PWM Blower Speed from the LME7 Burner Control

The current position of the actuator (LME73.../LME75...) or speed of the PWM blower (LME71... with PME71.901A1) can be viewed from the LME7 burner control using the following procedure.

1. Press and hold the A button on the LME7 burner control. "oP" will be displayed briefly, followed by the actuator position / PWM blower speed from 0-100%.
2. Holding the A button for less than three seconds will briefly display the actuator position / PWM blower speed. Upon releasing the A button, the display will return to normal.
3. Holding the A button for more than three seconds will leave the actuator position / PWM blower speed displayed for two minutes. This is indicated by the decimal point in front of the value flashing. After two minutes, or after pressing the + and - buttons together (escape), the display will return to normal.

Manually Adjusting the Actuator Position / PWM Blower Speed from the LME7 Burner Control

During main operation, the current position of the actuator (LME73.../LME75...) or speed of the PWM blower (LME71... with PME71.901A1) can be adjusted manually from the LME7 burner control using the following procedure. Setting the actuator position / PWM blower speed manually overrides the analog input signal on terminal X65 or the 3-position input signal on terminal X5-03.

1. Press and hold the A button on the LME7 burner control until the decimal point in front of the value being displayed begins flashing. This takes approximately five seconds. "oP" will be displayed briefly, followed by the actuator position / PWM blower speed from 0-100%.
2. Press and hold the A button again until "LoA" is displayed. Continue holding the A button and simultaneously press the + or - button to increase or decrease the actuator position / PWM blower speed respectively.
3. Once the desired actuator position / PWM blower speed is reached, release the A button. The LME7 will alternately display "LoA" and the current actuator position / PWM blower speed.
4. To leave manual mode, press the + and - buttons together (escape). "oP" will be displayed and the actuator position / PWM blower speed will be controlled by the analog input signal on terminal X65 or the 3-position input signal on terminal X5-03.

AZL23 Display Unit Icons

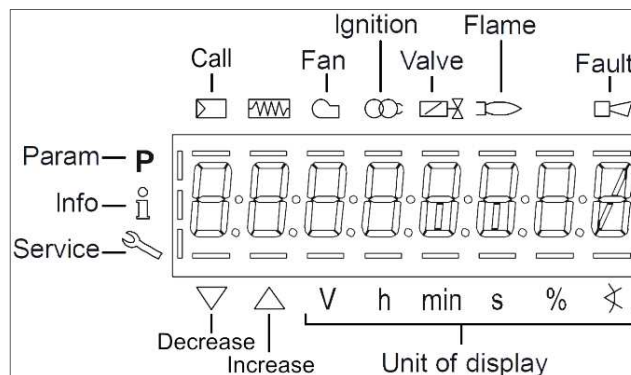

Figure 5-1: AZL23 Display Unit Icons

Section 1	Overview
Section 2	LME71 Wiring, Parameters, and Phase Diagrams
Section 3	LME73 Wiring, Parameters, and Phase Diagrams
Section 4	LME75 Wiring, Parameters, and Phase Diagrams
Section 5	Commissioning
Section 6	PWM Blowers
Section 7	Troubleshooting
Section 8	Modbus
Section 9	ACS410
Appendix A	Application Guide

Section 1	Overview
Section 2	LME71 Wiring, Parameters, and Phase Diagrams
Section 3	LME73 Wiring, Parameters, and Phase Diagrams
Section 4	LME75 Wiring, Parameters, and Phase Diagrams
Section 5	Commissioning
Section 6	PWM Blowers
Section 7	Troubleshooting
Section 8	Modbus
Section 9	ACS410
Appendix A	Application Guide

Introduction

The LME71 flame safeguard, when used with the PME71.901A1 program module, features an integrated, closed-loop PWM (pulse width modulation) blower control. This integrated control is used to modulate the speed of a PWM blower with firing rate. The LME71 transmits a PWM control signal to the blower, and then reads back the speed of the blower. On most PWM blowers, the speed feedback signal is taken from Hall Effect sensors that commutate the PWM blower motor.

Blower speed has a large impact on the air flow delivered to the burner, and thus has a large impact on the fuel-air ratio. A combustion air pressure switch offers only a small amount of protection, since the switch must be set to allow low fire operation when the PWM blower is spinning slowly and the blower output pressure is low. Blower speed feedback ensures that a blower failure will be quickly detected and the burner will shut down safely.

PWM Blower Fundamentals

A common type of variable speed blower is the brushless DC blower, commonly referred to as a PWM blower. These blowers typically have a variable speed drive and a DC brushless motor integrated into one housing. These blowers are typically fed single-phase or three-phase AC voltage directly, and use some type of AC to DC rectification to produce the DC voltage pulses necessary to drive the blower motor.

Unlike a brushed DC motor, field windings in a brushless motor are triggered (commutated) via non-contact Hall Effect sensors. In addition to commutating the motor, these Hall Effect sensors also provide a pulsed output that the LME7 can use for blower speed feedback. Wiring of the speed feedback signal is covered in Section 2.

Brushless DC motors usually do not have the same speed limitations as most three-phase blower motors do. While most three-phase blower motors are limited to about 3,800 RPM, some brushless DC motors used in blower applications will spin in excess of 8,000 RPM. This high-speed capability is attractive in a blower application since more air flow at higher pressures can be generated with a smaller blower. The LME7 can read blower speeds up to 9,000 RPM via the Hall Effect sensors in the blower.

Accurate speed control of a brushless DC motor can be more challenging as compared to a VFD and a three-phase AC motor. The primary reasons behind this are the electromechanical characteristics of the motors themselves. In brushless DC motors, the motor windings are being fed DC pulses of variable duration (hence these blowers being called pulse width modulation). The width of these pulses determines the blower's speed for a given torque output and for a given blower input voltage. All three of these variables – pulse width, torque output, and input voltage have a substantial impact on the blower's speed and can be regarded as primary variables.

Some PWM blowers have internal speed controls that compensate for torque output and input voltage variances. This is done by taking a commanded speed set point (dictated by the LME7) and adjusting the width of the pulse to achieve the commanded speed. PWM blowers having fast updating, properly tuned internal speed controls typically work well with the LME7.

Centrifugal Blower Fundamentals

Since a centrifugal blower is the piece of machinery being controlled by the LME7, a brief mention of its basic characteristics is warranted. Specifically, there are three fundamental "fan laws" that a person working with such equipment should be aware of. These are:

1. Air flow varies linearly with the speed of the blower. In other words, the CFM of the blower is directly proportional to the RPM of the blower.

$$\text{CFM (new)} = \frac{\text{RPM (new)}}{\text{RPM (old)}} \times \text{CFM (old)}$$

2. The static output pressure of the blower (SP) varies by the square of the change in RPM:

$$\text{SP (new)} = \left(\frac{\text{RPM (new)}}{\text{RPM (old)}} \right)^2 \times \text{SP (old)}$$

3. The required brake horsepower of the blower (BHP) varies by the cube of the change in RPM:

$$\text{BHP (new)} = \left(\frac{\text{RPM (new)}}{\text{RPM (old)}} \right)^3 \times \text{BHP (old)}$$

Example: A blower spinning at 1750 RPM produces 10 in WC of static pressure, 4500 CFM of air flow, and requires 20 BHP. What happens if the RPM is increased to 2750 RPM?

Assumptions: There is no air damper on the inlet to the blower, and system effects (such as the restriction due to heat exchangers, the burner's diffuser, etc...) are not taken into account.

Flow: $\text{CFM (new)} = (2750 / 1750) * 4500 = 7071 \text{ CFM}$

Pressure: $\text{SP (new)} = (2750 / 1750)^2 * 10 = 24.7 \text{ in WC}$

Power: $\text{BHP (new)} = (2750 / 1750)^3 * 20 = 78 \text{ BHP}$

Blower Speed Monitoring

To help ensure that the burner is either operated at a safe fuel-to-air ratio or is shut down, the blower speed is constantly monitored while a flame is present. The speed is monitored in a way that nuisance shutdowns are eliminated, but fast shutdowns will occur if the speed deviation is large. Two tolerance bands centered about the target speed are used. These bands are:

1. **Tolerance Band 1** - If the speed is within this band, it is considered acceptable and no action is taken. If the blower speed falls outside of this band, the speed control in the LME7 or the PWM blower will begin working to get it back inside this band. If the speed does not fall back inside Tolerance Band 1 within five seconds, a lockout occurs. The width of this band is adjustable via parameter 650.00 and the range is +/- 1.0 to 5.0% of the maximum blower speed (parameter 519).
2. **Tolerance Band 2** - If the blower speed ever falls outside of this band, a lockout occurs immediately. The width of this band is adjustable via parameter 650.01 and the range is +/- 1.0 to 10.0% of the maximum blower speed (parameter 519). Tolerance band 2 should be set to a larger value than tolerance band 1.

These bands are shown graphically in Figure 6-1.

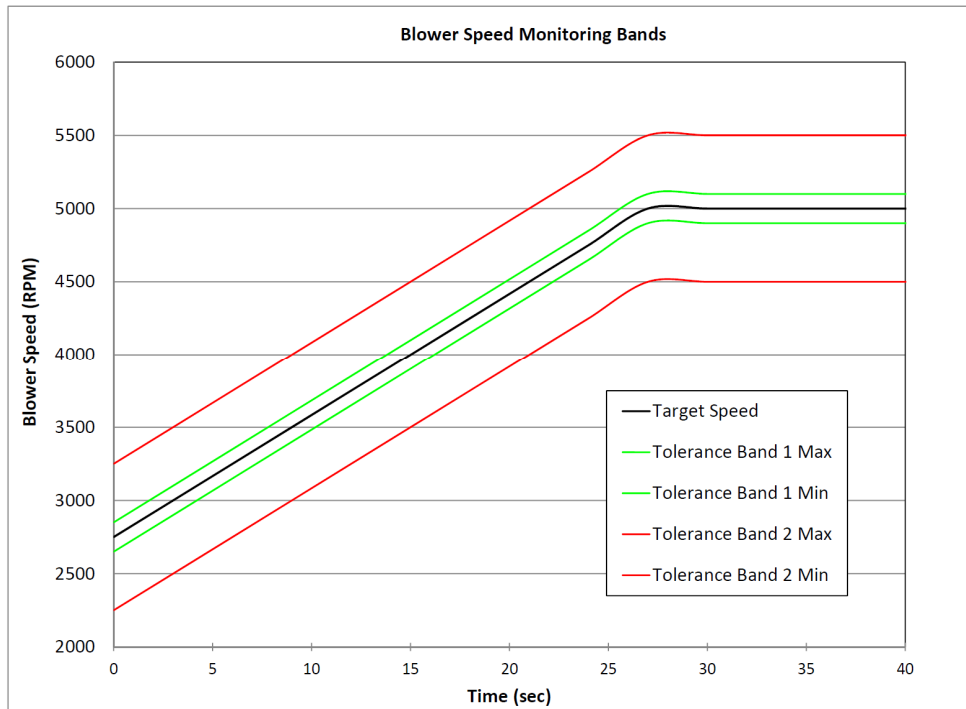

Name of Tolerance Band		Tolerance Band 1		Tolerance Band 2	
High Limit of Tolerance Band		+1.0% to 5.0%		+1.0% to 10.0%	
Low Limit of Speed Band		-1.0% to 5.0%		-1.0% to 10.0%	
Parameter to Adjust Width of Band		650.00		650.01	
Maximum Blower Speed (P519)		5000 RPM			
Tolerance Band Limits for Figure 6-1					
Tolerance band 1 = 2%		+/- 100 RPM		+/- 500 RPM	
Tolerance band 2 = 10%					

	Time	Target Speed		Max	Min	Max	Min
	sec	%	RPM	RPM	RPM	RPM	RPM
RAMP UP	0	55	2750	2850	2650	3250	2250
	3	60	3000	3100	2900	3500	2500
	6	65	3250	3350	3150	3750	2750
	9	70	3500	3600	3400	4000	3000
	12	75	3750	3850	3650	4250	3250
	15	80	4000	4100	3900	4500	3500
	18	85	4250	4350	4150	4750	3750
	21	90	4500	4600	4400	5000	4000
	24	95	4750	4850	4650	5250	4250
	27	100	5000	5100	4900	5500	4500
HIGH FIRE	30	100	5000	5100	4900	5500	4500
	33	100	5000	5100	4900	5500	4500
	36	100	5000	5100	4900	5500	4500
	39	100	5000	5100	4900	5500	4500
	42	100	5000	5100	4900	5500	4500

Figure 6-1: Blower Speed Monitoring Bands

Commissioning the LME7 when Using a PWM Blower

After verifying that all PWM blower-related components are installed and wired correctly, the LME7 burner control can be programmed for the PWM blower application.

Prerequisites

- Ensure that the PWM blower is a closed loop type, meaning that it is utilizing an onboard speed control properly tuned for that specific blower.
- Ensure that the maximum closed loop speed that the PWM blower is programmed for is adequate for the application.
- Ensure the wiring is correct, paying particular attention to the low voltage wiring. Some PWM blowers have their electronics internally powered from the high voltage, while others require separate, external low voltage power.

After these points are double-checked, the LME7 parameters can be set for the application.

1. Set the blower ramp times.

- a. Ramp up = Parameter 522
- b. Ramp down = Parameter 523

These ramp times should be set at least 10% longer than the capabilities of the connected PWM blower. For example, if the PWM blower can ramp up in 20 seconds, then parameter 522 should be set to at least 22 seconds. The same logic applies for the ramp down, parameter 523.

2. Set the maximum speed of the PWM blower via parameter 519. This should be copied directly from the blower nameplate or otherwise provided by the blower manufacturer.
3. Set the number of pulses per revolution for the PWM blower tachometer speed feedback signal via parameter 644. This should be provided by the blower manufacturer and is typically only found in the blower technical literature.
4. Set parameter 559 to activate or deactivate the LME7 internal speed control. For PWM blowers, especially those utilizing a properly tuned onboard speed control, parameter 559 is typically set to 0. Setting the value to 0 turns off the speed control inside the LME7 and allows the speed control to be performed solely by the PWM blower.
5. Set the PWM blower speed monitoring bands to values that are safe for the application. These are set via parameters 650.00 and 650.01. See complete explanation of these bands detailed earlier on pages 3 and 4.
6. Set the standby speed of the PWM blower via parameter 503.00. This is typically set to 0 RPM.
7. Set the prepurge and postpurge speed of the PWM blower via parameter 503.01. This is often set at the same value as the high fire speed (P2).

-
8. Set the ignition (P0), low fire (P1), and high fire (P2) blower speeds with the burner off. These values are found in the 400 set of parameters. To set these parameters, use the following procedure:
 - a. Log in at the Service or OEM access level. The display will say "400: Set". Press the info button.
 - b. The display will say "run". Press the + and - buttons together (escape). The display will then show the ignition speed P0.
 - c. To adjust the ignition speed P0, press and hold the A button while simultaneously pressing the + or - buttons to increase or decrease the ignition speed respectively. Once the desired ignition speed P0 has been set, press the + button.
 - d. The low fire speed P1 will be displayed. Press and hold the A button while simultaneously pressing the + or - buttons to increase or decrease the low fire speed respectively. Once the desired low fire speed P1 has been set, press the + button.
 - e. The high fire speed P2 will be displayed. Press and hold the A button while simultaneously pressing the + or - buttons to increase or decrease the high fire speed respectively. Once the desired high fire speed P2 has been set, press the + and - buttons together (escape) two times to get back to the normal screen (OFF).

 9. At this point, all critical PWM blower related parameters have been set.

Adjusting P0, P1, and P2 via the LME7 Built-in Display

1. While in standby (OFF), press and hold the A button and either the + or - button for more than five seconds until "OFF" starts blinking.
2. Give the LME7 a call for heat. The LME7 will proceed to start the burner. After prepurge is complete, the LME7 will slow the blower down to the preset ignition speed (P0).
3. At this point, the LME7 will alternately display P0 and a three-digit number. The three-digit number is the setting of the ignition speed P0 divided by 10. For example, if the display alternately displays P0 and 200, this means that the ignition speed is currently set for 2000 RPM.
4. To adjust the ignition speed, press and hold the A button while simultaneously pressing the + or - button to increase or decrease the speed respectively. The speed of the blower will change in real time. Once the desired ignition speed P0 has been set, press the info button.
5. The startup of the burner will continue. The burner will light off and establish flame. Once the burner has lit off, it will drive to the preset low fire speed (P1).
6. The LME7 will then alternately display P1 and a three-digit number that is representative of the low fire speed divided by 10. To adjust the low fire speed, press and hold the A button while simultaneously pressing the + or - button to increase or decrease the speed respectively. The speed of the blower will change in real time. Once the desired low fire speed P1 has been set, press the info button.
7. The LME7 will immediately drive to the preset high fire speed P2.
8. The LME7 will then alternately display P2 and a three-digit number that is representative of the high fire speed divided by 10. To adjust the high fire speed, press and hold the A button while simultaneously pressing the + or - button to increase or decrease the speed respectively. The speed of the blower will change in real time. Once the desired high fire speed P2 has been set, press the info button.
9. Press the + and - buttons together (escape) to return to normal operation. The PWM blower will now respond to the external load control signal being supplied to the LME7.

Adjusting P0, P1, and P2 via the AZL23 Display Unit

1. Log in at the Service or OEM access level. The display will say "400: Set". Press the info button.
2. The display will say "run". Give the LME7 a call for heat. The LME7 will proceed to start the burner. After prepurge is complete, the LME7 will slow the blower down to the preset ignition speed (P0).
3. At this point, the LME7 will alternately display P0 and the ignition speed.
4. To adjust the ignition speed, press and hold the A button while simultaneously pressing the + or - button to increase or decrease the speed respectively. The speed of the blower will change in real time. Once the desired ignition speed P0 has been set, press the info button.
5. The startup of the burner will continue. The burner will light off and establish flame. Once the burner has lit off, it will drive to the preset low fire speed (P1).
6. The LME7 will then alternately display P1 and the low fire speed. To adjust the low fire speed, press and hold the A button while simultaneously pressing the + or - button to increase or decrease the speed respectively. The speed of the blower will change in real time. Once the desired low fire speed P1 has been set, press the info button.
7. The LME7 will immediately drive to the preset high fire speed P2.
8. The LME7 will then alternately display P2 and the high fire speed. To adjust the high fire speed, press and hold the A button while simultaneously pressing the + or - button to increase or decrease the speed respectively. The speed of the blower will change in real time. Once the desired high fire speed P2 has been set, press the info button.
9. Press the + and - buttons together (escape) to return to normal operation. The PWM blower will now respond to the external load control signal being supplied to the LME7.

Additional Tips for Burners with PWM Blowers

- Most of the time, speed faults that are seen on the LME7 are caused by the PWM blower not being able to decelerate quickly enough when the blower is being ramped down. If fast ramp times are not critical for the application, ramp times (parameters 522 and 523) can be increased and this should correct the issue.
- The LME7 in combination with the PWM blower can be tested for proper operation while the LME7 is in standby (OFF). After the PWM blower parameters are set, the standby speed of the PWM blower can be adjusted with parameter 503.00. The actual speed as a % of the maximum blower speed (parameter 519) can be read back on parameter 936. If different blower speeds are set and plotted vs. the actual speed (936), the linearity of the PWM blower's speed response can be assessed.
- The ACS410 PC software has a trending package that is very useful when diagnosing PWM blower speed issues. In particular, the target speed (parameter 920) and the actual speed (parameter 936) can be plotted against one another in real time, and can be closely reviewed to see where the largest deviations occur.
- The combustion air pressure switch should be set by taking the PWM blower to 10% below the lowest anticipated low fire speed (if low fire is 50%, take the PWM blower to 40%) and setting the switch to open at that point. This should maximize the safety potential of the combustion air pressure switch and minimize nuisance air pressure trips. This can be done in standby by setting the standby speed of the blower to 10% lower than low fire and adjusting the switch to trip at this point.
- Most PWM blowers have their own internal speed control. However, when using a PWM blower that does not have its own internal speed control, parameter 559 must be set to 1 so that the LME7 can control the speed of the blower. When parameter 559 is set to 1, the LME7 controls the blower speed using the PID values set by parameters 676, 677, and 678. The default settings of these parameters are typically adequate.

Intentionally Left Blank

Section 1	Overview
Section 2	LME71 Wiring, Parameters, and Phase Diagrams
Section 3	LME73 Wiring, Parameters, and Phase Diagrams
Section 4	LME75 Wiring, Parameters, and Phase Diagrams
Section 5	Commissioning
Section 6	PWM Blowers
Section 7	Troubleshooting
Section 8	Modbus
Section 9	ACS410
Appendix A	Application Guide

Section 1	Overview
Section 2	LME71 Wiring, Parameters, and Phase Diagrams
Section 3	LME73 Wiring, Parameters, and Phase Diagrams
Section 4	LME75 Wiring, Parameters, and Phase Diagrams
Section 5	Commissioning
Section 6	PWM Blowers
Section 7	Troubleshooting
Section 8	Modbus
Section 9	ACS410
Appendix A	Application Guide

Troubleshooting Introduction

The LME7 has an extensive list of fault codes to help clarify the nature of any fault. Section 7-2 describes every fault code in detail and gives guidance on how to correct it.

When a fault occurs, the LME7 will alternate between displaying “Loc” and the fault number.

The fault history is stored in the 700 set of parameters. These are only accessible with an AZL23 remote display or through the ACS410 software. To access the 700 set of parameters on the AZL23, press and hold the info button until “SEr” is displayed, then let go. The LME7 stores the last 11 fault codes:

Parameter 701 displays information about the current status of the LME7.

Parameter 702 displays information about the most recent fault.

Parameter 703 displays information about the second most recent fault.

...

Parameter 711 displays information about the 10th most recent fault.

Each fault code listed has indexes that provide additional information about the fault:

Index 00 = Fault code

Index 01 = Start number

Index 02 = Phase

Index 03 = Load

Index 01 will display a value of “._.”. This means that the AZL23 display ran out of room to display the start number. When this happens, hold down the info button to display the value.

An example of how the AZL23 displays a fault code in the fault history is shown below:



Figure 7-1: LME7 Fault History Example with Indexes

Navigating the Fault History

To navigate the fault history, use the following key strokes on the AZL23.

- When the parameter number is flashing, press the “+” or “-” button to cycle through the list of faults (parameters 701-711).
- When the parameter number is flashing, press and hold the info button to move the cursor from the parameter number to the index number. This will cause the index number to begin flashing.
- When the index number is flashing, press the “+” or “-” button to cycle through the list of indexes (00-03).
- When the index number is flashing, press the “+” and “-” buttons together to escape and move the cursor from the index number to the parameter number. This will cause the parameter number to begin flashing.

Resetting Faults on the LME7 Burner Control

Faults can be reset in one of three ways on the LME7... burner control:

1. Pressing the info button on the LME7 burner control for 1-3 seconds.
Note: Pressing the info button for less than one second has no effect. Pressing the info button for more than three seconds places the LME7 into diagnostic mode.
2. Pressing the info button on the AZL23 remote display until the word “rESET” appears, then releasing.
Note: Releasing the info button before the word “rESET” appears has no effect. Pressing the info button too long accesses the “InFo” menu.
3. Connecting neutral to reset terminal X2-03.1 for more than one second. This is typically done with the use of a push button connected between neutral and X2-03.1.
Note: Connecting neutral to X2-03.1 for less than one second has no effect.

Accessing the Service (SEr) Menu

The service (SEr) menu contains the fault history as well as the 900 series of parameters that are used for diagnostic purposes, such as flame signal (954) and incoming voltage (951).

1. From the home screen (OFF), press and hold the info button until the word “SEr” is displayed, then release. The word “InFo” will briefly be displayed before “SEr”.
2. Press the + or - button to navigate through the parameters in the “SEr” menu.
3. When finished, press the “+” and “-” buttons together to escape.

Complete Fault Code List

Fault Code	Description of the Fault	Corrective Action
2	No flame at start-up	<p>A flame failure occurred during lightoff.</p> <ol style="list-style-type: none"> 1. Check the wiring of the ignition transformer, pilot valve, and main valve(s). 2. Ensure manual shutoff valves on the pilot gas line and main gas line are open. 3. Check the fuel / air ratio at lightoff. 4. Check the flame detector signal in the presence of a known flame source. Replace the flame detector if it does not produce the anticipated signal.
3	Air pressure switch open	<p>The air pressure switch connected to terminal X3-02.1 is open, causing a fault. Ensure the setpoint of the switch is set to an appropriate value. Check the wiring of the air pressure switch. If no air pressure switch is being used, place a jumper from terminal X2-01.3 to X3-02.1.</p>
4	Extraneous light	<p>An extraneous light (flame signal present when there should be none) fault occurred.</p> <ol style="list-style-type: none"> 1. Ensure that the source of light is not a flame. If it is, take corrective action immediately. 2. Ambient light can cause an extraneous light fault. Ensure the flame scanner is viewing a dark area. 3. UV scanners typically fail on, giving a false flame signal. Remove UV scanner and cover the bulb to ensure it is not seeing any light. Look inside the bulb and see if any purple arcs of electricity are occurring between the electrodes in the bulb. If there are, replace the UV scanner.
5	Air pressure switch closed	<p>The air pressure switch connected to terminal X3-02.1 is closed before the blower output is energized in phase 22, causing a fault. Ensure the setpoint of the switch is set to an appropriate value. Check the wiring of the air pressure switch. If no air pressure switch is being used, place a jumper from terminal X2-01.3 to X3-02.1.</p>
6	Actuator position fault	<p>The required position feedback from the connected SQM... actuator was not received.</p> <ol style="list-style-type: none"> 1. Ensure the potentiometer on the SQM... actuator is wired correctly. <ul style="list-style-type: none"> -For counter-clockwise actuators (SQM40..., SQM50...), terminal "c" on the potentiometer should be wired to terminal X66.1 on the LME7, and terminal "a" on the potentiometer should be wired to terminal X66.3 on the LME7. -For clockwise actuators (SQM41..., SQM50...R), terminal "a" on the potentiometer should be wired to terminal X66.1 on the LME7, and terminal "c" on the potentiometer should be wired to terminal X66.3 on the LME7. 2. Ensure the SQM... actuator is wired properly to the LME7, especially the position feedback on terminal X2-09.4 of the LME7. 3. Ensure no mechanical stops are preventing the actuator from reaching its expected position. 4. While not common, heavy vibration on the actuator can wear a track in the position feedback potentiometer. If the fault always occurs at the same actuator position, the actuator may need to be replaced, and the vibration needs to be reduced to avoid having a similar issue with the new actuator.

Fault Code	Description of the Fault	Corrective Action
7	Loss of flame	<p>A flame failure occurred during normal operation.</p> <ol style="list-style-type: none"> 1. Check the fuel / air ratio. 2. Check the flame detector signal in the presence of a known flame source. Replace the flame detector if it does not produce the anticipated signal.
10	Wiring or other error	<p>This fault is a catchall and can be caused by a variety of issues. See Section 7-3 for a list of all known causes of this fault. If none of the causes listed in Section 7-3 appears to be the cause, review all wiring on the LME7 and check to see if a wire is landed on an incorrect terminal.</p>
12	Fuel valve V2 leaking (PME73.840A1) Fuel valve V1 leaking (all other PME7s)	<p>On PME73.840A1, the downstream gas valve V2 failed valve proving. On all other PME7 program modules, the upstream gas valve V1 failed valve proving.</p> <ol style="list-style-type: none"> 1. Bubble test the gas valve to ensure the valve is not leaking. If the valve is leaking, replace the valve. 2. Ensure that the setpoint of the valve proving pressure switch is set to 50% of the inlet pressure to the upstream gas valve.
13	Fuel valve V1 leaking (PME73.840A1) Fuel valve V2 leaking (all other PME7s)	<p>On PME73.840A1, the upstream gas valve V1 failed valve proving. On all other PME7 program modules, the downstream gas valve V2 failed valve proving.</p> <ol style="list-style-type: none"> 1. Bubble test the gas valve to ensure the valve is not leaking. If the valve is leaking, replace the valve. 2. Ensure that the setpoint of the valve proving pressure switch is set to 50% of the inlet pressure to the upstream gas valve.
14	Proof-of-closure (POC) switch failure	<p>The POC switch is not in the expected state. If a POC switch exists, ensure it is wired to terminal X2-02.4 on the LME7. On an LME75 burner control, the source of power to the common side of the POC switch must come from terminal X2-02.3.</p> <p>If no POC switch exists, either set parameter 237 to 0 or install a jumper between terminals X2-02.3 and X2-02.4.</p>
20	Gas pressure fault	<p>One of the gas pressure switches wired to terminal X5-01.2 opened, causing a fault. It is common for both the high and low gas pressure switches to be wired to terminal X5-01.2, so the fault could be either a high gas or low gas event. Check the gas supply and open any manual shutoff valves. Check the wiring of all gas pressure switches. Check the setpoint of any gas pressure switches to ensure the setpoint is set to an appropriate value.</p>
21	High gas pressure fault	<p>The high gas pressure switch wired to terminal X2-02.4 (PME75.811A1) or X9-04.2 (PME75.812A1) opened, causing a fault. Check the wiring of the high gas pressure switch. Check the setpoint of the high gas pressure switch and ensure it is set to an appropriate value. Check pressure regulators for ruptured diaphragms or incorrect setpoints.</p>

Fault Code	Description of the Fault	Corrective Action
22	Safety loop open	Check all of the switches wired into the safety loop on terminal X3-04.1. One of the switches opened, causing the fault. Fix the condition that caused the switch to open and reset the fault.
60	Analog input out of range	The 4-20 mA input connected to terminal X65 is out of range. This input determines the position of the actuator or speed of the PWM blower. Check the wiring of the analog input. If a fault is not desired when the input drops below 4 mA, set parameter 654 to a 5.
83	PWM blower speed fault	<p>The speed of the PWM blower does not match the expected speed. More specifically, the blower speed fell outside of tolerance band 1 (parameter 650.00) for a time longer than the maximum speed deviation allowed (parameter 660), or the blower speed fell outside of tolerance band 2 (parameter 650.01). There are many possible corrective actions:</p> <ol style="list-style-type: none"> 1. Increase ramp time up (parameter 522) and/or ramp time down (parameter 523) to allow the blower more time to achieve the expected speed. 2. Increase the setting of tolerance band 1 (parameter 650.00) and/or tolerance band 2 (parameter 650.01). 3. Ensure that the maximum fan speed (parameter 519) and the number of pulses per revolution (parameter 644) are set correctly for the blower being used. 4. Inspect wiring from PWM blower to LME7 to ensure the tachometer speed feedback signal is wired correctly.
138	Restore process successful	There is no fault. This fault occurs when a parameter set was successfully restored from the PME7 program module to the LME7 base unit. Reset the fault.
139	No program module detected	This fault occurs when no PME7 program module is plugged into the LME7 base unit. Insert a PME7 program module into the LME7 base unit and reset the fault.
167	Manual lockout	A manual lockout is caused by pressing the info button and any other button, either on the LME7 base unit or on the AZL23 remote display. Reset the fault.
206	Inadmissible combination of units (LME7 / AZL23)	Reset the LME7. If the fault occurs continuously, replace the LME7 and / or AZL23.
225	PWM blower speed fault	The speed of the PWM blower dropped below the minimum prepurge speed (parameter 675.00) during prepurge, or the speed of the PWM blower exceeded the maximum ignition speed (parameter 675.01) during ignition. Adjust parameter 675.00 or 675.01, or adjust purge speed (503.01) or ignition speed (403.00).
226	PWM blower parameterization error	<p>The following parameter settings are not allowed. Correct the parameter setting that is incorrect and reset the fault.</p> <ol style="list-style-type: none"> 1. Speed low-fire (P1) > speed high-fire (P2) 2. Speed low-fire (P0) = 0 3. Maximum blower speed (parameter 519) = 0

Fault Code	Description of the Fault	Corrective Action
227	PWM blower parameterization error	One or more PWM blower settings are not compatible. Make sure the following three conditions on the minimum and maximum speed settings are met. <ol style="list-style-type: none"> 1. $516.00 \leq P0 \leq 516.01$ 2. $517.00 \leq P1 \leq 517.01$ 3. $518.00 \leq P2 \leq 518.01$
rSt Er1	Incompatible PME7 and LME7	The PME7 program module and LME7 base unit being used are incompatible. PME71 program modules are only compatible with LME71 base units, PME73 program modules are only compatible with LME73 base units, and PME75 program modules are only compatible with LME75 base units.
rSt Er2		
rSt Er3	Fault during restore process	The PME7 program module was removed during the restore process. Re-install the PME7 program module and reset the fault to complete the restore process.
bAC Er3	Fault during backup process	The PME7 program module was removed during the backup process. Re-install the PME7 program module and reset the fault. Perform the backup process again.
Err PrC	No program module detected	This fault occurs when no PME7 program module is plugged into the LME7 base unit. Insert a PME7 program module into the LME7 base unit and reset the fault.

Other Common Faults

Known Causes of Loc 10

Loc 10 is a catchall fault that can be caused by a variety of issues. All known causes of Loc 10 are listed below in Table 7-1.

Table 7-1: All Known Causes of Loc 10

Cause #	LME71/73/75	Description	Phase	Corrective Action
1	All	Line power is directly connected to safety loop input X3-04.1	OFF	Power to the safety loop must be sourced from terminal X3-04.2
2	LME73/75 only	PV jumper missing	40	Add a jumper between terminals X2-09B.7 and X2-09B.8
3	All	Line power directly connected to blower output terminal X2-01.3	OFF	Correct feedback/wiring error
4	All	K4 relay contacts welded	21	With no power on the LME7, check continuity across pins X2-01.3 and X2-02.3. If there is continuity, replace the LME7. See Note 1 below.
5	All	Line power directly connected to POC source terminal X2-02.3	OFF	Correct feedback/wiring error
6	All	Line power directly connected to SV output terminal X6-03.3	OFF	Correct feedback/wiring error
7	All	Ambient temperature exceeds 140°F	OFF	Adjust the temperature back within the controller's acceptable range. Add enclosure cooling if necessary.
8	All	Flame failure incorrectly being logged as Loc 10	44, 50	Adjust combustion to avoid flame failures during light-off

Notes:

1. It is likely that the rating on the blower motor output X2-01.3 was exceeded. Output X2-01.3 has a 2 Amp rating at 120 V, 50/60 Hz.

LME7 LED is Flashing Red

When the LED on the front of the LME7 is flashing red very quickly, this indicates that the LME7 has been placed into Diagnostic Mode. While being in Diagnostic Mode does not prevent successful operation of the burner, it does remove the status that is typically displayed by the LED, as well as causes operators to incorrectly conclude that the LME7 is damaged.

There is no practical use for Diagnostic Mode. To exit Diagnostic Mode, simply press and hold the info button until the LED flashes yellow, then release the info button.

Section 1	Overview
Section 2	LME71 Wiring, Parameters, and Phase Diagrams
Section 3	LME73 Wiring, Parameters, and Phase Diagrams
Section 4	LME75 Wiring, Parameters, and Phase Diagrams
Section 5	Commissioning
Section 6	PWM Blowers
Section 7	Troubleshooting
Section 8	Modbus
Section 9	ACS410
Appendix A	Application Guide

Section 1	Overview
Section 2	LME71 Wiring, Parameters, and Phase Diagrams
Section 3	LME73 Wiring, Parameters, and Phase Diagrams
Section 4	LME75 Wiring, Parameters, and Phase Diagrams
Section 5	Commissioning
Section 6	PWM Blowers
Section 7	Troubleshooting
Section 8	Modbus
Section 9	ACS410
Appendix A	Application Guide

Modbus RTU and BACnet MS/TP Communication

Introduction

The physical connection from the LME7 burner control to the Modbus RTU or BACnet MS/TP system is made via an external OCI417.10 interface module. The OCI417.10 is compatible with all LME7... burner controls and PME7... program modules.

Physical Connections

Power

Power to the OCI417.10 must be either 9-24VDC or 9-24VAC (nominal). Power consumption is 2.5W or less. **SCC part number AGA15-24** is available as a suitable power supply.

Terminal designations:

Label	Function
L+	DC + / AC ~
N-	DC - / AC ~

Connection to the LME7...

The connection from the OCI417.10 to the LME7... should be made with a 4-wire RJ-11 cable with reversed connections (voice cable), such as **SCC part number TDC207**. **Maximum allowed cable length is 3 meters.**

X56 Port LME7...



Pin 1: 5V Out
Pin 2: Transmit
Pin 3: Receive
Pin 4: 0V Out

OCI417.10



Pin 1: 0V In
Pin 2: Transmit
Pin 3: Receive
Pin 4: 5V In

Note that while the OCI417.10 is connected, the AZL23... or PC tool ACS410 via OCI410... may not be simultaneously connected. Connecting multiple interfaces to the LME7... using a multi-way cable or splitter may result in damage to the connected LME7..., OCI417.10, AZL23..., or OCI410...



Connection to the BMS

The connection from the BMS to the OCI417.10 is via terminal block. The physical medium is RS-485. Multiple RS-485 nodes may be connected in a daisy-chain. For long runs (typically greater than 1,000 feet) or noisy environments, termination may be required on the end node.

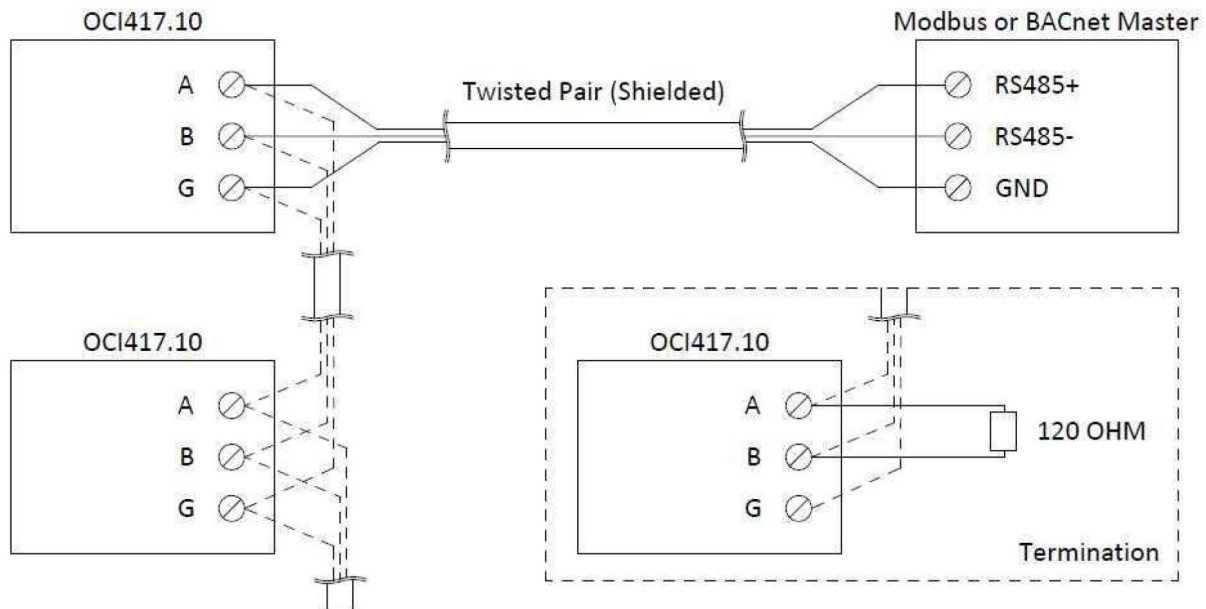

Terminal designations:

Label	Function
A	RS-485 Data (+)
B	RS-485 Data (-)
G	RS-485 Common Ground

Status LED

The status LED annunciates the status of the OCI417.10 and the connection to the LME7...

Color	Status
Green Flashing	No Connection to LME7...
Green / Red Alternating	Communicating with LME7...
Red Flashing	Internal Error OCI417.10

Tx/Rx LED

The LED will flash red to indicate incoming communication on the RS-485 connection. The LED will flash green to indicate outgoing communication. With normal communication, the LED will rapidly alternate between green and red. NOTE: If the poll rate is fast the flashes may be very brief and hard to notice.

Modbus RTU Connection Details

Modbus RTU protocol selection and addressing is done using the PC tool **OCI417 Configuration Utility** (see next section).

Supported addresses: 1-247

Supported baud rates: 2400, 4800, 9600, 19200, 38400, 57600 and 115200

Supported data bits: 8

Supported parity and stop bits: none (1 or 2 stop bits), odd (1 stop bit), and even (1 stop bit)

Supported function codes: 3 (read holding registers), 4 (read input registers)

Maximum read length: 125 (if beginning and ending registers are valid addresses)

BACnet MS/TP Connection Details

BACnet MS/TP protocol selection and addressing is done using the PC tool **OCI417 Configuration Utility** (see next section).

Supported addresses: 0-127

Supported baud rates: 9600, 19200, 38400, 57600, 76800 and 115200

Supported data bits: 8

Supported parity and stop bits: none (1 stop bit)

Supported device instances: 0-4194302

Using the OCI417 Configuration Utility

1. To download the OCI417 configuration utility, go to the following website and click the “OCI417.10 Configuration Utility” link to download and install the software.

<http://www.scccombustion.com/flame.htm>.

2. Once installed, double-click the icon to open the configuration utility.



3. The utility will open and show the connection status of the OCI417.10.

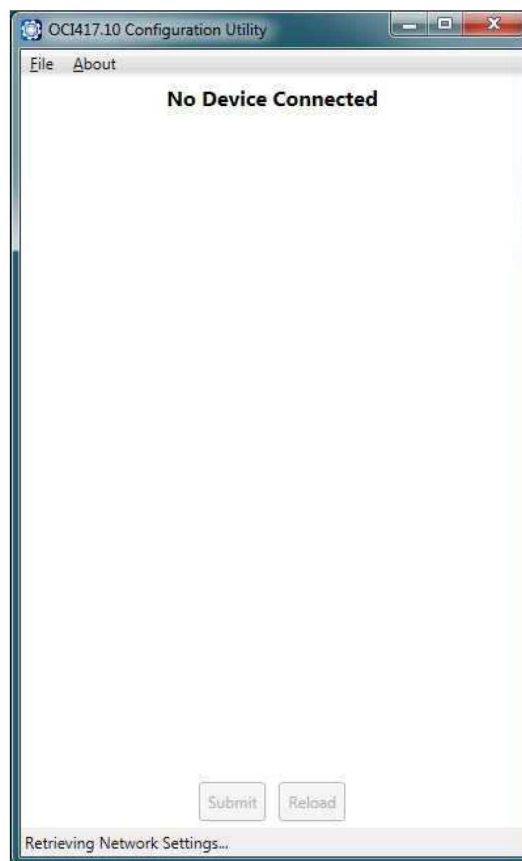

4. Use a mini-USB cable to connect the OCI417.10 to the computer, such as **SCC part number AGA5-05M**. A driver may self-install the first time a connection is made. The connected device will then be indicated on the screen.

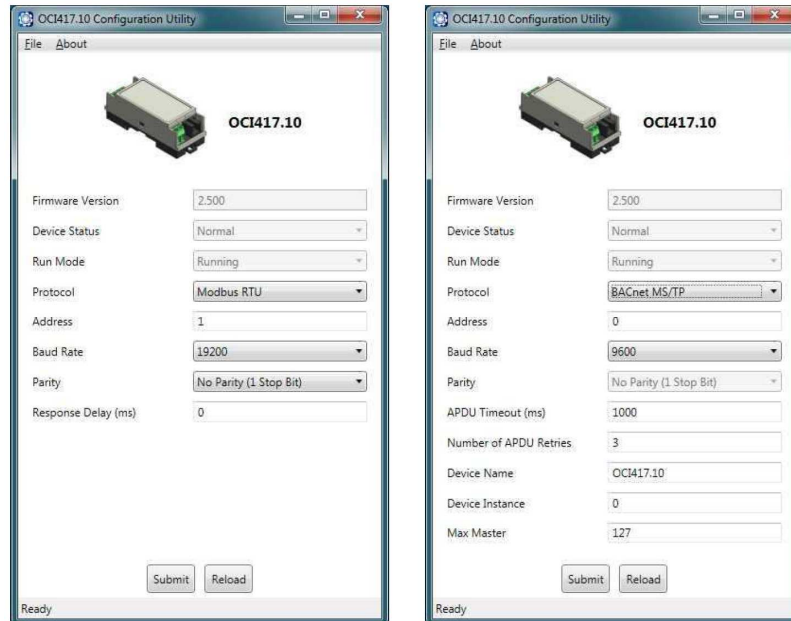

5. The protocol can be changed between Modbus RTU and BACnet MS/TP from this screen. See the previous sections for further details on the protocol-specific settings that can be changed. Once the desired settings have been entered, click **Submit** to apply. Click **Reload** to refresh the displayed settings.

Updating the OCI417.10 Firmware

1. From the OCI417.10 Configuration Utility, click **File -> Update Device...**



2. Locate the supplied update file with a **.duf** extension and click **Open**.



3. The device will automatically reboot and reconnect with the OCI417.10 Configuration Utility once the firmware update is complete. When a device is connected, the firmware version is shown as one of the read-only parameters.



Modbus Mapping

ADDRESS	ACCESS	DESCRIPTION	FORMAT	NOTES
0	R	PHASE	Unsigned Int 16	
1	R	FLAME INTENSITY	Unsigned Int 16	x10
2	R	MAINS VOLTAGE	Unsigned Int 16	x10
3	R	STARTUPS RESETTABLE	Unsigned Int 32	
5	R	STARTUPS TOTAL	Unsigned Int 32	
7	R	RELAY K12 CYCLES	Unsigned Int 32	
9	R	RELAY K11 CYCLES	Unsigned Int 32	
11	R	RELAY K2 CYCLES	Unsigned Int 32	
13	R	RELAY K1 CYCLES	Unsigned Int 32	
15	R	MAX RELAY CYCLES	Unsigned Int 32	
17	R	CURRENT OUTPUT PERCENT	Unsigned Int 16	> 100 IS STAGES (101=S1, 102=S2)
18	R	ACTUATOR ACTUAL PERCENT	Unsigned Int 16	65535 (-1) IS NOT OPTIONED
19	R	ACTUATOR TARGET PERCENT	Unsigned Int 16	65535 (-1) IS NOT OPTIONED
20	R	EXT LOAD CONTROLLER PERCENT	Unsigned Int 16	65535 (-1) IS NOT OPTIONED
21	R	FAN SPEED RPM	Unsigned Int 16	65535 (-1) IS NOT OPTIONED
22	R	FAN SPEED PERCENT	Unsigned Int 16	65535 (-1) IS NOT OPTIONED
23	R	TARGET FAN SPEED PERCENT	Unsigned Int 16	65535 (-1) IS NOT OPTIONED
24	R	PWM SIGNAL PERCENT	Unsigned Int 16	65535 (-1) IS NOT OPTIONED
25	R	STATUS INPUT WORD LME71/LME73	Unsigned Int 16	SEE BIT BREAKDOWN
25 bit 0	R	SAFETY LIMIT (SK)	Boolean	TERMINAL X3.04.1
25 bit 1	R	PROOF OF CLOSURE (POC)	Boolean	TERMINAL X2.02.4
25 bit 4	R	PRESS SW VALVE PROVING (P LT)	Boolean	TERMINAL X9.04.2
25 bit 5	R	LOW GAS PRESSURE SWITCH (Pmin)	Boolean	TERMINAL X5.01.2
25 bit 6	R	CONTROL SWITCH (ON/OFF)	Boolean	TERMINAL X5.03.1
25 bit 7	R	COMBUSTION AIR SWITCH (LP)	Boolean	TERMINAL X3.02.1
25 bit 8	R	RESET TERMINAL (EK2)	Boolean	TERMINAL X2.03.1
25 bit 10	R	INCREASE MODULATION (LR-OPEN)	Boolean	TERMINAL X5.03.3
25 bit 11	R	DECREASE MODULATION (LR-CLOSED)	Boolean	TERMINAL X5.03.2
25 bit 12	R	ACTUATOR FEEDBACK (SA-R)	Boolean	TERMINAL X2.09.4
25 bit 14	R	RESET BUTTON LME	Boolean	
26	R	STATUS OUTPUT WORD	Unsigned Int 16	SEE BIT BREAKDOWN
26 bit 0	R	FLAME PRESENT	Boolean	
26 bit 1	R	ALARM (AL)	Boolean	TERMINAL X2.03.3
26 bit 2	R	NO COMM TO LME	Boolean	STATUS FROM OCI417
26 bit 7	R	SAFETY VALVE (SV)	Boolean	TERMINAL X6.03.3
26 bit 8	R	ACTUATOR LOW-FIRE (SA-KL)	Boolean	TERMINAL X2.09.2
26 bit 9	R	ACTUATOR HIGH-FIRE (SA-NL)	Boolean	TERMINAL X2.09.3
26 bit 10	R	PILOT VALVE (PV)	Boolean	TERMINAL X7.01.3
26 bit 12	R	IGNITION (Z)	Boolean	TERMINAL X4.02.3
26 bit 13	R	FAN (M)	Boolean	TERMINAL X2.01.3
26 bit 14	R	VALVE 1 (V1)	Boolean	TERMINAL X7.04.4
26 bit 15	R	VALVE 2 (V2)	Boolean	TERMINAL X7.02.3
27	R	STATUS INPUT WORD LME75	Unsigned Int 16	SEE BIT BREAKDOWN
27 bit 0	R	PRESS SW VALVE PROVING (P LT)	Boolean	TERMINAL X9.04.2
27 bit 1	R	VALVE PROVING ENABLE (LT) HIGH GAS PRESSURE SWITCH (Pmax) PROOF OF CLOSURE (POC)	Boolean	TERMINAL X2.02.4

Modbus Mapping

ADDRESS	ACCESS	DESCRIPTION	FORMAT	NOTES
27 bit 2	R	INCREASE MODULATION (LR-OPEN)	Boolean	TERMINAL X5.03.3
27 bit 3	R	DECREASE MODULATION (LR-CLOSED)	Boolean	TERMINAL X5.03.2
27 bit 4	R	COMBUSTION AIR SWITCH (LP)	Boolean	TERMINAL X3.02.1
27 bit 5	R	LOW GAS PRESSURE SWITCH (Pmin)	Boolean	TERMINAL X5.01.2
27 bit 6	R	RESET BUTTON LME	Boolean	
27 bit 7	R	RESET TERMINAL (EK2)	Boolean	TERMINAL X2.03.1
27 bit 8	R	ACTUATOR FEEDBACK (SA-R)	Boolean	TERMINAL X2.09.4
27 bit 9	R	SAFETY LIMIT (SK)	Boolean	TERMINAL X3.04.1
27 bit 10	R	CONTROL SWITCH (ON/OFF)	Boolean	TERMINAL X5.03.1
27 bit 11	R	INPUT CAMS (SA-ZL)	Boolean	TERMINAL X2.09.8
50	R	PRODUCT ID	String	
60	R	BURNER ID	String	
70	R	OEM PRODUCT ID	String	
80	R	PME PRODUCT ID	String	
90	RW	OCI PRODUCT ID	String	WRITABLE DATA AREA
100	R	CURRENT ERROR CODE	Unsigned Int 16	
101	R	CURRENT ERROR STARTUPS	Unsigned Int 32	
103	R	CURRENT ERROR PHASE	Unsigned Int 32	PHASE IS 0 WHEN NO ERROR
104	R	CURRENT ERROR LOAD	Unsigned Int 16	255 IS NO LOAD RECORDED
110	R	HISTORY 1 ERROR CODE	Unsigned Int 16	
111	R	HISTORY 1 ERROR STARTUPS	Unsigned Int 32	
113	R	HISTORY 1 ERROR PHASE	Unsigned Int 32	PHASE IS 0 WHEN NO ERROR
114	R	HISTORY 1 ERROR LOAD	Unsigned Int 16	255 IS NO LOAD RECORDED
120	R	HISTORY 2 ERROR CODE	Unsigned Int 16	
121	R	HISTORY 2 ERROR STARTUPS	Unsigned Int 32	
123	R	HISTORY 2 ERROR PHASE	Unsigned Int 32	PHASE IS 0 WHEN NO ERROR
124	R	HISTORY 2 ERROR LOAD	Unsigned Int 16	255 IS NO LOAD RECORDED
130	R	HISTORY 3 ERROR CODE	Unsigned Int 16	
131	R	HISTORY 3 ERROR STARTUPS	Unsigned Int 32	
133	R	HISTORY 3 ERROR PHASE	Unsigned Int 32	PHASE IS 0 WHEN NO ERROR
134	R	HISTORY 3 ERROR LOAD	Unsigned Int 16	255 IS NO LOAD RECORDED
140	R	HISTORY 4 ERROR CODE	Unsigned Int 16	
141	R	HISTORY 4 ERROR STARTUPS	Unsigned Int 32	
143	R	HISTORY 4 ERROR PHASE	Unsigned Int 32	PHASE IS 0 WHEN NO ERROR
144	R	HISTORY 4 ERROR LOAD	Unsigned Int 16	255 IS NO LOAD RECORDED
150	R	HISTORY 5 ERROR CODE	Unsigned Int 16	
151	R	HISTORY 5 ERROR STARTUPS	Unsigned Int 32	
153	R	HISTORY 5 ERROR PHASE	Unsigned Int 32	PHASE IS 0 WHEN NO ERROR
154	R	HISTORY 5 ERROR LOAD	Unsigned Int 16	255 IS NO LOAD RECORDED
160	R	HISTORY 6 ERROR CODE	Unsigned Int 16	
161	R	HISTORY 6 ERROR STARTUPS	Unsigned Int 32	
163	R	HISTORY 6 ERROR PHASE	Unsigned Int 32	PHASE IS 0 WHEN NO ERROR
164	R	HISTORY 6 ERROR LOAD	Unsigned Int 16	255 IS NO LOAD RECORDED
170	R	HISTORY 7 ERROR CODE	Unsigned Int 16	
171	R	HISTORY 7 ERROR STARTUPS	Unsigned Int 32	
173	R	HISTORY 7 ERROR PHASE	Unsigned Int 32	PHASE IS 0 WHEN NO ERROR

Modbus Mapping

ADDRESS	ACCESS	DESCRIPTION	FORMAT	NOTES
174	R	HISTORY 7 ERROR LOAD	Unsigned Int 16	255 IS NO LOAD RECORDED
180	R	HISTORY 8 ERROR CODE	Unsigned Int 16	
181	R	HISTORY 8 ERROR STARTUPS	Unsigned Int 32	
183	R	HISTORY 8 ERROR PHASE	Unsigned Int 32	PHASE IS 0 WHEN NO ERROR
184	R	HISTORY 8 ERROR LOAD	Unsigned Int 16	255 IS NO LOAD RECORDED
190	R	HISTORY 9 ERROR CODE	Unsigned Int 16	
191	R	HISTORY 9 ERROR STARTUPS	Unsigned Int 32	
193	R	HISTORY 9 ERROR PHASE	Unsigned Int 32	PHASE IS 0 WHEN NO ERROR
194	R	HISTORY 9 ERROR LOAD	Unsigned Int 16	255 IS NO LOAD RECORDED
200	R	HISTORY 10 ERROR CODE	Unsigned Int 16	
201	R	HISTORY 10 ERROR STARTUPS	Unsigned Int 32	
203	R	HISTORY 10 ERROR PHASE	Unsigned Int 32	PHASE IS 0 WHEN NO ERROR
204	R	HISTORY 10 ERROR LOAD	Unsigned Int 16	255 IS NO LOAD RECORDED

BACnet Mapping

ADDRESS	DESCRIPTION	UNITS	ACTIVE TEXT	INACTIVE TEXT
AV1	PHASE	NO UNITS	--	--
AV2	FLAME INTENSITY	PERCENT	--	--
AV3	MAINS VOLTAGE	VOLTS	--	--
AV4	STARTUPS RESETTABLE	NO UNITS	--	--
AV5	STARTUPS TOTAL	NO UNITS	--	--
AV6	RELAY K12 CYCLES	NO UNITS	--	--
AV7	RELAY K11 CYCLES	NO UNITS	--	--
AV8	RELAY K2 CYCLES	NO UNITS	--	--
AV9	RELAY K1 CYCLES	NO UNITS	--	--
AV10	MAX RELAY CYCLES	NO UNITS	--	--
AV11	CURRENT OUTPUT PERCENT	PERCENT	--	--
AV12	ACTUATOR ACTUAL PERCENT	PERCENT	--	--
AV13	ACTUATOR TARGET PERCENT	PERCENT	--	--
AV14	EXT LOAD CONTROLLER PERCENT	PERCENT	--	--
AV15	FAN SPEED RPM	RPM	--	--
AV16	FAN SPEED PERCENT	PERCENT	--	--
AV17	TARGET FAN SPEED PERCENT	PERCENT	--	--
AV18	PWM SIGNAL PERCENT	PERCENT	--	--
AV19	CURRENT ERROR CODE	NO UNITS	--	--
AV20	CURRENT ERROR STARTUPS	NO UNITS	--	--
AV21	CURRENT ERROR PHASE	NO UNITS	--	--
AV22	CURRENT ERROR LOAD	PERCENT	--	--
AV23	HISTORY 1 ERROR CODE	NO UNITS	--	--
AV24	HISTORY 1 ERROR STARTUPS	NO UNITS	--	--
AV25	HISTORY 1 ERROR PHASE	NO UNITS	--	--
AV26	HISTORY 1 ERROR LOAD	PERCENT	--	--
AV27	HISTORY 2 ERROR CODE	NO UNITS	--	--
AV28	HISTORY 2 ERROR STARTUPS	NO UNITS	--	--
AV29	HISTORY 2 ERROR PHASE	NO UNITS	--	--
AV30	HISTORY 2 ERROR LOAD	PERCENT	--	--
AV31	HISTORY 3 ERROR CODE	NO UNITS	--	--
AV32	HISTORY 3 ERROR STARTUPS	NO UNITS	--	--
AV33	HISTORY 3 ERROR PHASE	NO UNITS	--	--
AV34	HISTORY 3 ERROR LOAD	PERCENT	--	--
AV35	HISTORY 4 ERROR CODE	NO UNITS	--	--
AV36	HISTORY 4 ERROR STARTUPS	NO UNITS	--	--
AV37	HISTORY 4 ERROR PHASE	NO UNITS	--	--
AV38	HISTORY 4 ERROR LOAD	PERCENT	--	--
AV39	HISTORY 5 ERROR CODE	NO UNITS	--	--
AV40	HISTORY 5 ERROR STARTUPS	NO UNITS	--	--
AV41	HISTORY 5 ERROR PHASE	NO UNITS	--	--
AV42	HISTORY 5 ERROR LOAD	PERCENT	--	--
AV43	HISTORY 6 ERROR CODE	NO UNITS	--	--
AV44	HISTORY 6 ERROR STARTUPS	NO UNITS	--	--
AV45	HISTORY 6 ERROR PHASE	NO UNITS	--	--

BACnet Mapping

ADDRESS	DESCRIPTION	UNITS	ACTIVE TEXT	INACTIVE TEXT
AV46	HISTORY 6 ERROR LOAD	PERCENT	--	--
AV47	HISTORY 7 ERROR CODE	NO UNITS	--	--
AV48	HISTORY 7 ERROR STARTUPS	NO UNITS	--	--
AV49	HISTORY 7 ERROR PHASE	NO UNITS	--	--
AV50	HISTORY 7 ERROR LOAD	PERCENT	--	--
AV51	HISTORY 8 ERROR CODE	NO UNITS	--	--
AV52	HISTORY 8 ERROR STARTUPS	NO UNITS	--	--
AV53	HISTORY 8 ERROR PHASE	NO UNITS	--	--
AV54	HISTORY 8 ERROR LOAD	PERCENT	--	--
AV55	HISTORY 9 ERROR CODE	NO UNITS	--	--
AV56	HISTORY 9 ERROR STARTUPS	NO UNITS	--	--
AV57	HISTORY 9 ERROR PHASE	NO UNITS	--	--
AV58	HISTORY 9 ERROR LOAD	PERCENT	--	--
AV59	HISTORY 10 ERROR CODE	NO UNITS	--	--
AV60	HISTORY 10 ERROR STARTUPS	NO UNITS	--	--
AV61	HISTORY 10 ERROR PHASE	NO UNITS	--	--
AV62	HISTORY 10 ERROR LOAD	PERCENT	--	--
BV1	SAFETY LIMIT (SK) LME71/73	--	CLOSED	OPEN
BV2	SAFETY LIMIT (SK) LME75	--	CLOSED	OPEN
BV3	PROOF OF CLOSURE (POC) LME71/73	--	CLOSED	OPEN
BV4	VALVE PROVING ENABLE (LT) LME75 HIGH GAS PRESS SW (Pmax) LME75 PROOF OF CLOSURE (POC) LME75	--	CLOSED	OPEN
BV5	PRESS SW VALVE PROVING (P LT) LME71/73	--	CLOSED	OPEN
BV6	PRESS SW VALVE PROVING (P LT) LME75	--	CLOSED	OPEN
BV7	LOW GAS PRESSURE SWITCH (Pmin)	--	CLOSED	OPEN
BV8	CONTROL SWITCH (ON/OFF) LME71/73	--	CLOSED	OPEN
BV9	CONTROL SWITCH (ON/OFF) LME75	--	CLOSED	OPEN
BV10	COMBUSTION AIR SWITCH (LP) LME71/73	--	CLOSED	OPEN
BV11	COMBUSTION AIR SWITCH (LP) LME75	--	CLOSED	OPEN
BV12	RESET TERMINAL (EK2) LME71/73	--	CLOSED	OPEN
BV13	RESET TERMINAL (EK2) LME75	--	CLOSED	OPEN
BV14	INCREASE MODULATION (LR-OPEN)	--	CLOSED	OPEN
BV15	DECREASE MODULATION (LR-CLOSED)	--	CLOSED	OPEN
BV16	RESET BUTTON LME	--	CLOSED	OPEN
BV17	INPUT CAMS (SA-ZL) LME75	--	CLOSED	OPEN
BV18	FLAME PRESENT	--	FLAME	NO FLAME
BV19	ALARM (AL)	--	ALARM	NO ALARM
BV20	NO COMM TO LME	--	OK	NO COMM
BV21	ACTUATOR FEEDBACK (SA-R)	--	CLOSED	OPEN
BV22	SAFETY VALVE (SV)	--	CMD ON	CMD OFF
BV23	ACTUATOR LOW-FIRE (SA-KL)	--	CMD ON	CMD OFF
BV24	ACTUATOR HIGH-FIRE (SA-NL)	--	CMD ON	CMD OFF
BV25	PILOT VALVE (PV)	--	CMD ON	CMD OFF
BV26	IGNITION (Z)	--	CMD ON	CMD OFF

BACnet Mapping

ADDRESS	DESCRIPTION	UNITS	ACTIVE TEXT	INACTIVE TEXT
BV27	FAN (M)	--	CMD ON	CMD OFF
BV28	VALVE 1 (V1)	--	CMD ON	CMD OFF
BV29	VALVE 2 (V2)	--	CMD ON	CMD OFF

Unused Inputs

Any inputs unused by the selected PME... will still annunciate. For example, although PME71.111A1 does not support valve proving, applying 120VAC to terminal X9-04.2 will still cause Modbus address 25, bit 4 to show this terminal as active.

Intentionally Left Blank

Section 1	Overview
Section 2	LME71 Wiring, Parameters, and Phase Diagrams
Section 3	LME73 Wiring, Parameters, and Phase Diagrams
Section 4	LME75 Wiring, Parameters, and Phase Diagrams
Section 5	Commissioning
Section 6	PWM Blowers
Section 7	Troubleshooting
Section 8	Modbus
Section 9	ACS410
Appendix A	Application Guide

Section 1	Overview
Section 2	LME71 Wiring, Parameters, and Phase Diagrams
Section 3	LME73 Wiring, Parameters, and Phase Diagrams
Section 4	LME75 Wiring, Parameters, and Phase Diagrams
Section 5	Commissioning
Section 6	PWM Blowers
Section 7	Troubleshooting
Section 8	Modbus
Section 9	ACS410
Appendix A	Application Guide

ACS410 Software Introduction

The LME7 burner control can be completely programmed using either the AZL23 or a PC with the ACS410 software. Most people find that using the AZL23 is more convenient than the ACS410 for a “manual” setup of the LME7 parameters. However, the ACS410 has additional capabilities that are not available with the AZL23 / LME7 alone. These additional, valuable capabilities are:

1. Saving and printing all LME7 settings and information in a report format. This provides a convenient, comprehensive startup report.
2. Saving and uploading entire LME7 parameter sets to or from a PC.
3. Viewing and saving trends.
4. Viewing a status screen of the LME7 inputs and outputs as well as the LME7 operating state.

The following pages will cover the software installation and how to connect the LME7 to a PC, as well as explain how to utilize the basic capabilities of the ACS410 software, including parameter sets, startup reports, trending, and the status screen.

Since most people prefer to use the AZL23 to set parameters in the LME7, the procedure to do this with ACS410 will not be covered in this guide. For technical information about how to program the LME7 through the ACS410 software, email techsupport@scccombustion.com or go to www.scccombustion.com/lmv3.htm and click on “ACS410 Software Operating Instructions”.

The ACS410 software can be used with the following PC operating systems:

- Windows XP (service pack 2 minimum)
- Windows 7
- Windows 8.1
- Windows 10

ACS410 cannot be used with the following PC operating systems:

- Windows Vista
- Windows ME

Software Installation

The following steps outline the procedure for installing the ACS410 software on a PC.

1. The ACS410 software can be downloaded from the SCC website:
 - a. Go to *www.scccombustion.com/lmv3.htm*.
 - b. Click on "ACS410 Software..." towards the bottom to begin the download.

2. Once the ACS410 software has been downloaded, double-click on the setup.exe file. This should start the installation. Pick the desired options as the installation prompts:
 - a. Select the installation language and click "OK".
 - b. When prompted, click "Next".
 - c. Accept the license agreement and click "Next".
 - d. Select the folder where the ACS410 software will be installed. The default folder is *C:\Program Files (x86)\Siemens\ACS410*. Click "Next".
 - e. Select the folder where the ACS410 software shortcuts will be installed in the Start Menu. The default folder is *ACS410*. Click "Next".
 - f. Select the checkbox if an ACS410 desktop icon is desired. Click "Next".
 - g. Review the installation choices. If everything looks correct, click "Install".
 - h. The ACS410 software will now be installed on the PC.

3. Once the ACS410 software installation is complete, a prompt to install the OCI410 device drivers will appear. Perform the following steps to install these drivers:
 - a. Click "Next".
 - b. The OCI410 drivers will now be installed.
 - c. Once the OCI410 drivers have been installed successfully, click "Finish".
 - d. Select the checkbox if it is desired for ACS410 to launch immediately, then click "Finish".

4. At this point, the ACS410 software is ready to run.

Connecting to a PC

The following steps summarize the procedure for establishing communication between the LME7 and a PC.

1. An OCI410 interface module is required to connect the LME7 to a PC. Three different interface modules are available:

Table 9-1: Available Interface Modules to Connect the LME7 to a PC

Interface Module	Capabilities
OCI410.20	User level PC interface module. Permits access to user level parameters only without the ability to perform parameter backups
OCI410.30	Service level PC interface module. Permits access to user and service level parameters and the ability to perform parameter backups
OCI410.40	OEM level PC interface module. Permits access to all parameters and the ability to perform parameter backups

It is highly recommended to acquire at least the OCI410.30 interface module.

2. Once the interface module is acquired, the LME7 can be connected to the PC. If an AZL23 is being used, unplug the AZL23 from the LME7. Connect the RJ11 plug of the OCI410 interface module into the X56 port on the LME7. Connect the USB plug of the OCI410 interface module into a USB port on the PC. The ACS410 software should automatically identify which COM port the OCI410 interface module is plugged into.

3. Open the ACS410 software. Click “OK” on the safety note and the “Login” dialog box will appear. Click the “Online” button, and then select which password level is desired (IS – user, SO – service, OEM – OEM). If attempting to connect at the service or OEM level, enter the password. Remember that the OCI410.30 module is required to access the service level, and the OCI410.40 module is required to access the OEM level. Then click “Connect”.

Note: The password is case-sensitive, and only certain characters are allowed to be typed into the password field. For this reason, it is much easier to click the “#” button next to the password and click on each character instead of typing the password manually.

Saving a Parameter Set to a PC

The following steps outline the procedure for saving parameter sets to a PC.

1. Ensure that the ACS410 software is open, and the PC is connected to the LME7 at the service or OEM level. See previous sections if necessary.
2. The LME7 must have a burner ID in order to perform a parameter backup. The burner ID is set via parameter 113 through the ACS410 software. To set the burner ID, click on the "Parameters" tab. Click the "+" button next to the "100:General" set of parameters to expand it. Click on parameter 113 and then press the ">" button to move parameter 113 to the right side of the window. Once that is done, click on the "+" button in the upper-right corner of the window and a box will appear called "Change parameter value". Delete the existing value and type in any number from one to eight digits in length for the burner ID. Press "OK". Click the "Save" button in the lower-right corner and a box will appear called "Changed parameters". Click "OK" for the parameter change to take effect.
3. Click on the "Backup / Restore" tab. Click on "Backup" in the lower-right corner.
4. A box will appear called "Backup description". The default file name is the current date and time. It is highly recommended to change the file name to something more job-specific. Additionally, information can be added for description, device number, burner type, and burner serial number. Once all of the relevant information has been entered, click "OK".
5. After about a minute, a box should appear stating that the backup was successful and the backup file should now be listed on the screen. The default location for storing parameter sets is *C:\Program Files (x86)\Siemens\ACS410\bkp*. Notice that two files are created in this folder: one with a .bkp file extension and one with a .unl file extension. Both files are necessary in order to view the parameter set or restore it to an LME7.

Note: The parameter set is stored in machine language, so it is not useful as a startup report. See the following section called "Creating an LME7 Startup Report" for the procedure for creating and printing a comprehensive startup report.

Uploading a Parameter Set to an LME7

The following steps outline the procedure for uploading parameter sets from a PC to an LME7.

1. Ensure that the ACS410 software is open, and the PC is connected to the LME7 at the service or OEM level. See previous sections if necessary.
2. Click on the “Backup / Restore” tab. A list of stored parameter sets will display on the screen. Select the parameter set to be uploaded into the LME7 and click on “Restore” in the lower-right corner. **This file will overwrite the parameter set on the LME7 and will determine the behavior of the LME7. Be sure that the correct file is selected.**
3. A prompt will appear asking to confirm that the proper file was selected. Click “Yes”. After about a minute, a box should appear stating that the upload was successful. If an error message is returned, see below for the cause of the error:

Burner ID: The burner ID of the data set stored on the PC does not match the burner ID of the LME7. View the burner ID (parameter 113) of the stored parameter set and ensure that it matches the burner ID displayed by parameter 113 on the LME7.

Note: This only applies if the burner ID of the LME7 has been modified from its default value, which is undefined (all dashes). You can always overwrite the parameters on an LME7 with an undefined burner ID.

Incompatible parameter sets: The current software version of the LME7 is not compatible with the software version of the parameter set stored on the PC.

Different types of units: It is not possible to copy the parameter set from one version of LME7 to another version of LME7. For example, a parameter set saved from an LME71.111A1 burner control cannot be restored into an LME73.811A1 burner control - it can only be restored into another LME71.111A1 burner control.

Creating an LME7 Startup Report

The following steps outline the procedure for saving, viewing, and printing a startup report to a PC.

1. Open the ACS410 software. Instead of logging in, click the “Offline” button. Then click the “Backup” button and press “OK”. The ACS410 is now in offline mode and not communicating with the LME7.
2. The screen should list all of the parameter backups that have previously been made. If a new parameter backup needs to be made before creating the startup report, see the previous section called “Saving a Parameter Set to a PC”.
3. Select the parameter set to be used for creating the startup report. Then click on “Load” in the lower-right corner.
4. The “Info / Service” tab will now display all of the user level parameters and the fault history of the selected parameter set. The “Parameters” tab will display all of the service and OEM level parameters of the selected parameter set.
5. Select the “File” dropdown menu, and click on “Report”. Enter a description of the parameter set if desired, then click on “OK” to generate the startup report.
6. A print preview of the startup report will be displayed. The startup report displays every parameter setting and the fault history.
7. To print the startup report, click “Print”. The startup report can also be saved in PDF format by printing it to a PDF writer. Most people prefer to have a PDF file of the parameter list and fault history. These pieces provide a very inclusive LME7 startup report.

Synchronizing the LME7 and PME Parameters

The ACS410 software can be used to synchronize the parameter set used by the LME7 and the backup copy stored on the PME chip.

1. Ensure that the ACS410 software is open, and the PC is connected to the LME7 at the service or OEM level. See previous sections if necessary.
2. Click on the “PME Backup / Restore” tab.
3. To overwrite the parameter backup that is stored on the PME chip with the current LME7 parameters, click on “Backup”. A window will appear asking if you are sure you would like to proceed with the backup. Click “Yes”. The backup takes approximately one minute. After the backup is complete, the LME7 will display “bAC End” which means that the backup is complete. A reset of the LME7 burner control is required to get rid of the “bAC End” message.
4. To overwrite the current LME7 parameters with the parameter backup that is stored on the PME chip, click on “Restore”. A window will appear asking if you are sure you would like to proceed with the restore. Click “Yes”. The restore takes approximately one minute. After the restore is complete, the LME7 will display “rSt End” which means that the restore is complete. A reset of the LME7 burner control is required to get rid of the “rSt End” message.

Saving and Viewing Trends

The ACS410 software can be used to view and save trends. Trending enables a technician to easily view and quantify system behavior over time. The following steps outline the procedure for viewing and saving trends with the ACS410 software.

1. Open the ACS410 software and connect at the desired access level. For example, when logged in at the user level, only user level parameters can be trended. See previous sections if necessary. Most parameters that are desirable to trend are user level parameters (900 series parameters). After the connection is established, click on the “Trending” tab. An example of the trending screen is shown below in Figure 9-1.

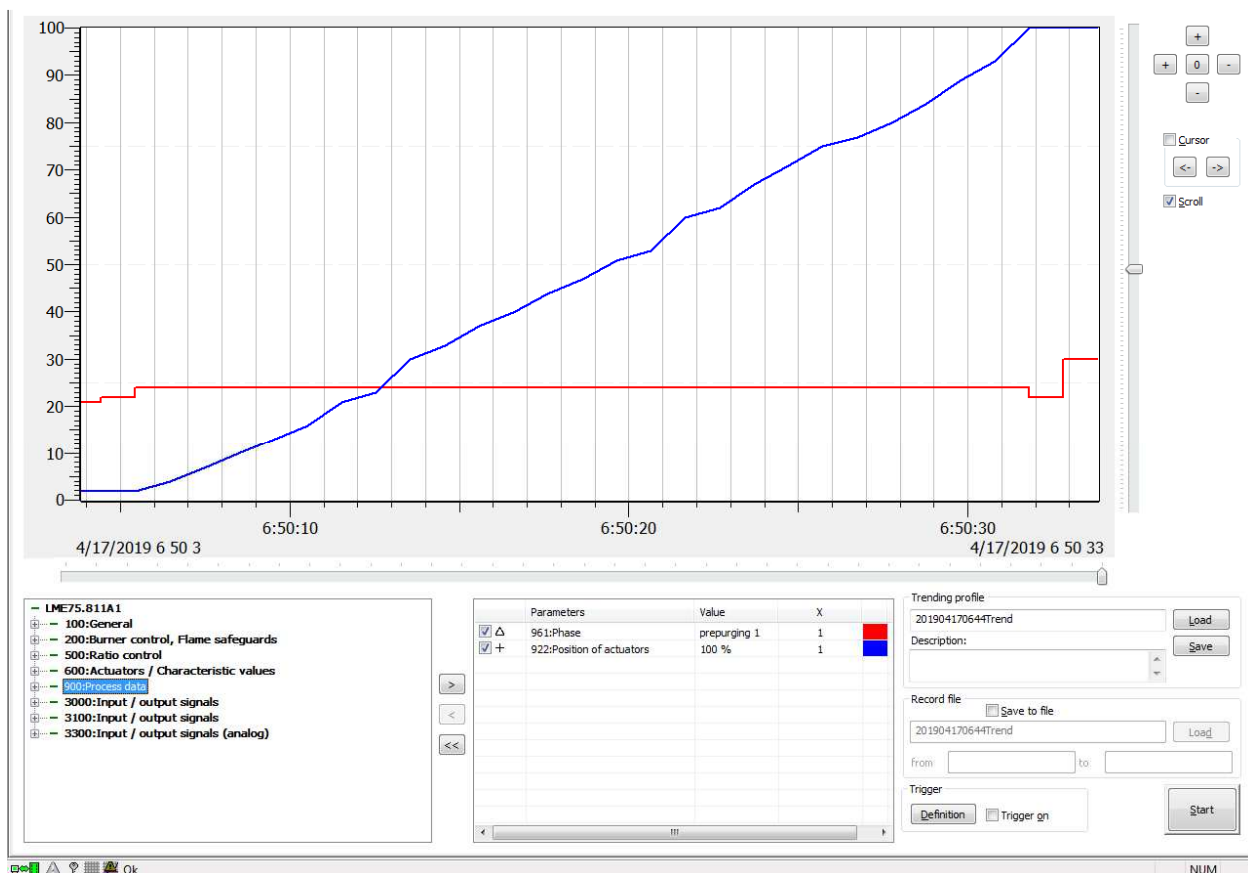

Figure 9-1: The ACS410 Trending Screen

2. All of the parameters available to be trended are listed in the lower-left corner. Double-click on any parameter or use the “>” button to select it as a parameter to be trended. A maximum of nine parameters can be trended at one time.
3. Use the “X” column to select a multiplier other than 1. Click on the color square next to the “X” column to change the color of the trend.

4. Once all of the trend settings (trending profile) have been set, these settings can be saved if desired. To save the trending profile, enter a file name in the “Trending profile” text box. The default name is the current date and time. Add a description if desired, and then click “Save”. Trending profiles are stored at: *C:\Program Files (x86)\Siemens\ACS410\tn*. All trending profiles are saved as .ptd files. Once the trending profile has been saved, a dialog box will appear stating the save was successful. Click “OK”.
5. Before starting the trend, click on the “Save to file” check box if the trending data is to be stored to a file. Enter a file name in the provided text box. The default name is the current date and time.
6. Click the “Start” button to start the trending. Use the “+” and “-” buttons to adjust the scale of the trend, or click the “0” button to return to the initial scale. Check the “Cursor” check box to add a double line showing the cursor and to open a pop-up window showing the exact values of the selected parameters. When the “Cursor” button is checked, the “<-” and “->” buttons can be used to change the cursor’s position and update the values in the pop-up window accordingly.
7. The trend will be buffered until the “Stop” button is clicked. The trending data will now be saved under the file name created in step 5. Trending data is stored in the following location: *C:\Program Files (x86)\Siemens\ACS410\tn*. Each set of trending data creates two files: one with a .unl format and one with a .dtd format. Both files are necessary if the trend is to be viewed at a later time through the ACS410 software.
8. To view a previously saved trend through the ACS410 software, click “Login” at the top of the screen. Click the “Offline” button, then the “Trending” button, and then click “OK”. A list of the saved trending data sets will appear. Choose the trending data that is to be viewed and click “Load”.
9. To open previously saved trending data in Microsoft Excel, first open Microsoft Excel. Click on “File” and then click “Open”. Navigate to the *C:\Program Files (x86)\Siemens\ACS410\tn* folder, and open the .dtd file corresponding to the trending data to be opened. If the .dtd file does not appear, select “All Files” in the dropdown menu in the lower right corner to ensure all file types are displayed. Once the .dtd file is opened, the trending data will be displayed in a clear, readable format.

Viewing the Status Screen

When connected to the LME7, the ACS410 can provide a status screen. This provides a useful summary of the LME7 inputs and outputs, as well as the operating state of the LME7. The following steps outline the procedure for viewing the ACS410 status screen.

1. Open the ACS410 software, and connect to the LME7 at any password level.
2. Once connected, click on the “Status” tab at the top of the screen. The status screen will appear detailing the operating state of the LME7. The status screen looks like Figure 9-2 below.

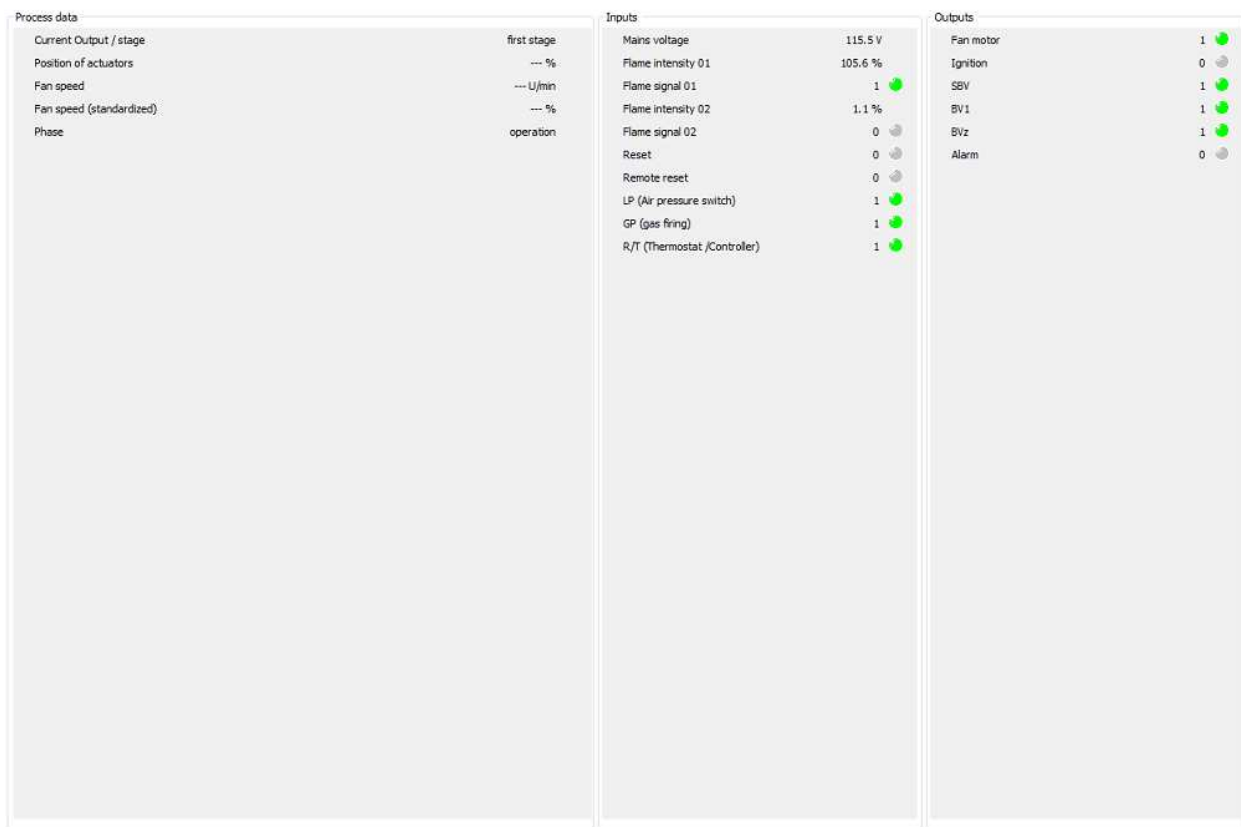

Figure 9-2: The ACS410 Status Screen

Section 1	Overview
Section 2	LME71 Wiring, Parameters, and Phase Diagrams
Section 3	LME73 Wiring, Parameters, and Phase Diagrams
Section 4	LME75 Wiring, Parameters, and Phase Diagrams
Section 5	Commissioning
Section 6	PWM Blowers
Section 7	Troubleshooting
Section 8	Modbus
Section 9	ACS410

Appendix A

Application Guide

Section 1	Overview
Section 2	LME71 Wiring, Parameters, and Phase Diagrams
Section 3	LME73 Wiring, Parameters, and Phase Diagrams
Section 4	LME75 Wiring, Parameters, and Phase Diagrams
Section 5	Commissioning
Section 6	PWM Blowers
Section 7	Troubleshooting
Section 8	Modbus
Section 9	ACS410

Appendix A

Application Guide

Appendix A: LME7 Application Guide



Description

The LME7 Application Guide includes programming, wiring, and operation examples of the control system for the most common applications.

Table of Contents

Honeywell Modutrol IV Motor with the LME75

Introduction.....	3
Setup Procedure without Valve Proving	3
Sequence of Operation without Valve Proving.....	5
Setup Procedure with Valve Proving	7
Sequence of Operation with Valve Proving	9
PME75.811A1 Program Sequence with Relays	12

Two Flame Detectors

Introduction.....	13
Procedure and Notes	13
Wiring Diagrams	14

Honeywell Modutrol IV with the LME75

Introduction

The Siemens LME75 burner control is designed specifically for use with a Siemens SQM4... or SQM5... series actuator. However, with some simple programming changes and the addition of only a few relays, the LME75 can be set up to safely and effectively control a Honeywell Modutrol IV motor.

An LME75.000A1 burner control with the PME75.811A1 program module must be used. No other LME7... burner control or PME7... program module will successfully work in this application. The Honeywell Modutrol IV motor must have high fire and low fire limit switches and can be either a 0-135 Ohm or 4-20 mA motor.

There are two separate procedures outlined below. The first procedure summarizes how to properly connect the LME75 to the Honeywell Modutrol IV motor when valve proving is not being used. This procedure only requires two relays (one DPST relay and one SPDT relay). The second procedure explains how to connect the LME75 to the Honeywell Modutrol IV motor when valve proving is being used. This procedure requires four relays (one 3PST relay, one SPDT relay, and two SPST relays).

Setup Procedure without Valve Proving

1. The following procedure should be used when valve proving is not being utilized.
2. Set the following parameters in the LME75 as described below:

Parameter 241 = 0

Parameter 259 = Greater than or equal to the running time of the Honeywell Modutrol IV motor being used

Parameter 260 = Greater than or equal to the running time of the Honeywell Modutrol IV motor being used

Parameter 515.01 = 1

Parameter 560 = 0

3. Wire the LME75.000A1 burner control, Honeywell Modutrol IV motor, and two relays as shown in Figure A-1. See Section 4 for more details on how to wire in other devices to the LME75.

Honeywell Modutrol IV with the LME75 (continued)

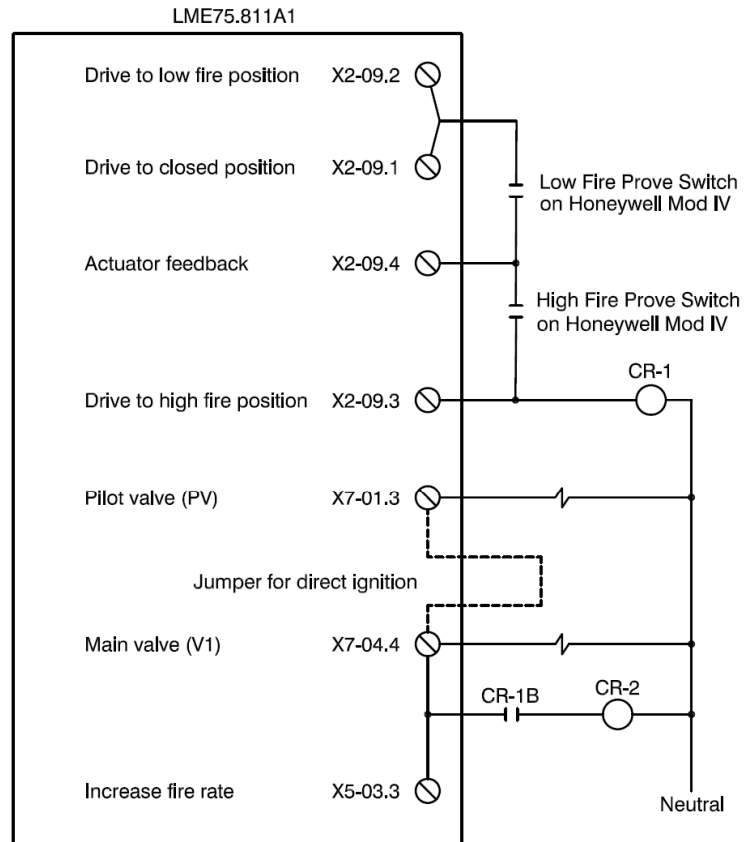

0-135 Ohm Honeywell Modutrol IV

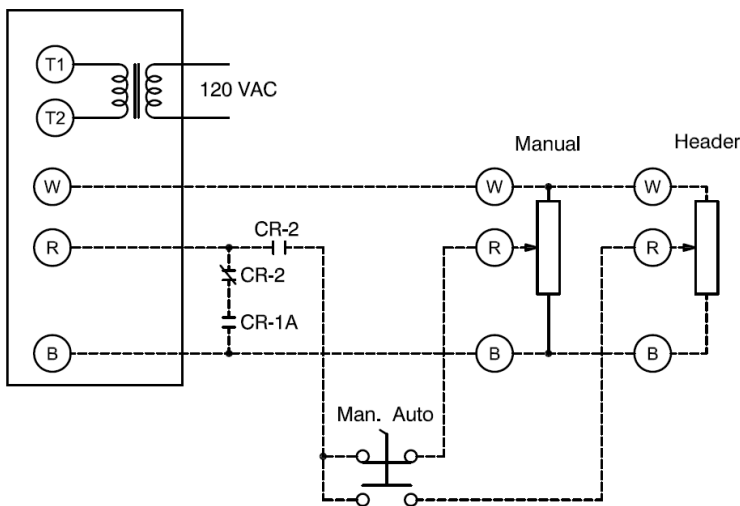

4-20 mA Honeywell Modutrol IV

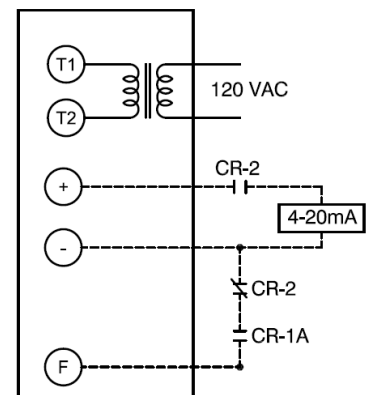

Figure A-1: Wiring a Honeywell Mod IV Motor to the LME75 (no Valve Proving)

Honeywell Modutrol IV with the LME75 (continued)

Sequence of Operation without Valve Proving

1. The LME75 is in standby. All valves are closed and all relays are de-energized. All relay contacts are as shown in the electrical schematic. The Honeywell Modutrol IV motor (hereafter referred to as mod motor) is at the low fire position.
2. The LME75 receives a call for heat. Output X2-09.1 is energized in phase 21 to drive the mod motor to low fire. Since the mod motor is already at the low fire position, the low fire proving switch is closed, and actuator feedback input X2-09.4 is energized.
3. Output X2-09.3 is energized in phase 24 to drive the mod motor to high fire. Relay CR-1 is energized. Normally open contact CR-1A closes, connecting terminals R and B on 0-135 Ohm mod motors or terminals F and - on 4-20 mA mod motors. This drives the mod motor to the high fire position. Once the mod motor reaches the high fire position, the high fire proving switch closes, and actuator feedback input X2-09.4 is energized. Normally open contact CR-1B also closes, but this has no effect since main valve output terminal X7-04.4 is de-energized during this phase.
4. The LME75 progresses to phase 22 and phase 30 (prepurge). During this time, output X2-09.3 remains energized, keeping the mod motor at the high fire position. Actuator feedback input X2-09.4 is required to remain energized during these phases, proving that the mod motor is at the high fire position for the full length of the prepurge.
5. Output X2-09.3 de-energizes in phase 36, de-energizing relay CR-1. Contact CR-1A opens, removing the connection that was keeping the mod motor to high fire. Since normally open contact CR-2 remains open, the mod motor drives to the low fire position. Output X2-09.2 is energized in phase 36. Once the mod motor reaches the low fire position, the low fire proving switch closes, and actuator feedback input X2-09.4 is energized.
6. If the jumper for direct ignition is not installed, the LME75 progresses through phases 40, 42, and 44 without any change to the mod motor. During these phases, the LME75 lights off the pilot and establishes a flame signal. The mod motor remains at the low fire position, and actuator feedback input X2-09.4 is required to remain energized during these phases, proving that the mod motor is at the low fire position through the light-off sequence.

Honeywell Modutrol IV with the LME75 (continued)

7. Main valve output X7-04.4 is energized in phase 50 (for piloted burners) or phase 40 (for non-piloted burners). Input X5-03.3 is energized, which has no effect. Output X2-09.3 is de-energized, so normally open contact CR-1B remains open, and relay CR-2 remains de-energized. The mod motor remains at the low fire position. The LME75 lights off the main burner and progresses through the end of phase 52 like this.
8. The LME75 transitions to operation phase oP. During phase oP, power on input X5-03.3 is directly transmitted to output X2-09.3, causing relay CR-1 to energize. Normally open contact CR-1B closes, energizing relay CR-2. Normally open contact CR-2 closes, allowing the modulation signal (0-135 Ohm or 4-20 mA) to control the mod motor. Normally closed contact CR-2 opens, preventing the connection of terminals R and B on 0-135 Ohm mod motors or terminals F and - on 4-20 mA mod motors. During phase oP, the mod motor is controlled by an external control signal, and the LME75 does not require any type of position feedback.
9. The LME75 loses the call for heat and transitions to phase oP1. Output X2-09.2 is energized to drive the mod motor to low fire before shutting the fuel valves. Once the mod motor reaches the low fire position, the low fire proving switch closes, and actuator feedback input X2-09.4 is energized.
10. Postpurge (phase 74) occurs at low fire. No actuator position feedback is required during postpurge.
11. Output X2-09.1 is energized in phase 10 to drive the mod motor to low fire. Since the mod motor is already at the low fire position, the low fire proving switch is closed, and actuator feedback input X2-09.4 is energized.
12. The LME75 transitions to standby, displayed as "OFF" on the LME75 and AZL23.

Honeywell Modutrol IV with the LME75 (continued)

Setup Procedure with Valve Proving

1. The following procedure should be used when valve proving is being utilized.
2. Set the following parameters in the LME75 as described below:
 - Parameter 241 = 1
 - Parameter 259 = Greater than or equal to the running time of the Honeywell Modutrol IV motor being used
 - Parameter 260 = Greater than or equal to the running time of the Honeywell Modutrol IV motor being used
 - Parameter 515.01 = 1
 - Parameter 560 = 0
3. Wire the LME75.000A1 burner control, Honeywell Modutrol IV motor, and four relays as shown in Figure A-2. See Section 4 for more details on how to wire in other devices to the LME75.

Honeywell Modutrol IV with the LME75 (continued)

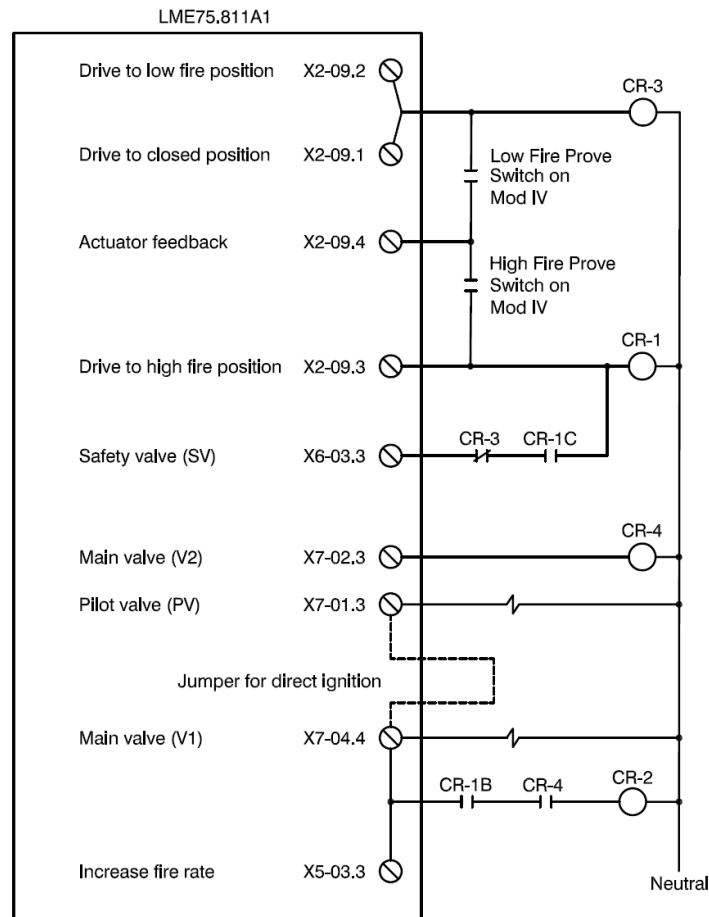

0-135 Ohm Honeywell Modutrol IV

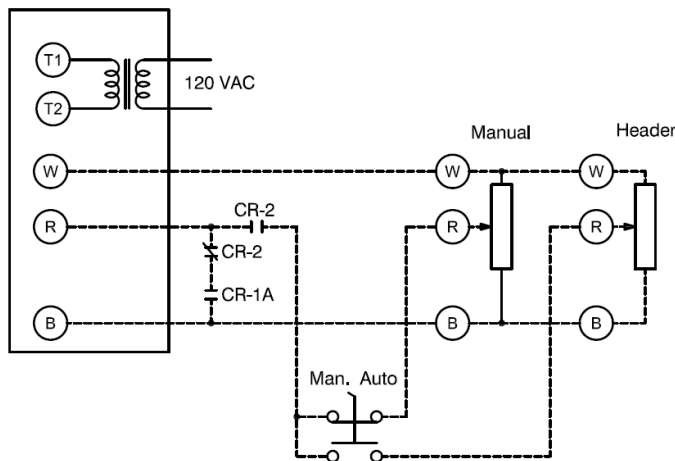

4-20 mA Honeywell Modutrol IV

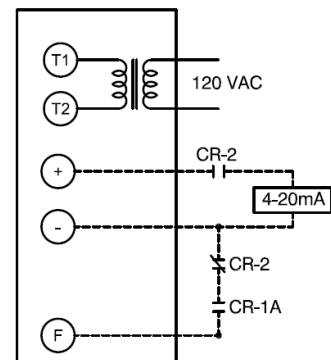

Figure A-2: Wiring a Honeywell Mod IV Motor to the LME75 (with Valve Proving)

Honeywell Modutrol IV with the LME75 (continued)

Sequence of Operation with Valve Proving

1. The LME75 is in standby. All valves are closed and all relays are de-energized. All relay contacts are as shown in the electrical schematic. The Honeywell Modutrol IV motor (hereafter referred to as mod motor) is at the low fire position.
2. The LME75 receives a call for heat. Output X2-09.1 is energized in phase 21 to drive the mod motor to low fire. Relay CR-3 is energized. Output X6-03.3 energizes as well, but this has no effect since normally closed contact CR-3 is open. Since the mod motor is already at the low fire position, the low fire proving switch is closed, and actuator feedback input X2-09.4 is energized.
3. Output X2-09.3 is energized in phase 24 to drive the mod motor to high fire. Relay CR-1 is energized. Normally open contact CR-1A closes, connecting terminals R and B on 0-135 Ohm mod motors or terminals F and - on 4-20 mA mod motors. This drives the mod motor to the high fire position. Once the mod motor reaches the high fire position, the high fire proving switch closes, and actuator feedback input X2-09.4 is energized. Normally open contact CR-1B also closes, but this has no effect since main valve output terminal X7-04.4 is de-energized during this phase.
4. The LME75 progresses to phase 22 and phase 30 (prepurge). During this time, output X2-09.3 remains energized*, keeping the mod motor at the high fire position. Actuator feedback input X2-09.4 is required to remain energized during these phases, proving that the mod motor is at the high fire position for the full length of the prepurge.

* When valve proving is activated, the valve proving sequence typically takes place during shutdown. However, after a lockout or a power cycle of the LME75, valve proving takes place during prepurge as well as postpurge on the next startup. During the valve proving sequence, output X2-09.3 de-energizes. To ensure the mod motor remains at the high fire position during prepurge, power to relay CR-1 is latched in through relay contact CR-1C. The latching circuit is broken when relay CR-3 is energized in phase 36, thus opening normally closed contact CR-3. Also during valve proving, main valve outputs X7-04.4 and X7-02.3 are briefly energized, but not at the same time. This ensures relay CR-2 is never energized during valve proving, which would drive the actuator off of the high fire position.

Honeywell Modutrol IV with the LME75 (continued)

5. Output X2-09.3 de-energizes and output X2-09.2 energizes in phase 36. These actions de-energize relay CR-1 and energize relay CR-3. Normally open contact CR-1A opens, removing the connection that was keeping the mod motor to high fire. Since normally open contact CR-2 remains open, the mod motor drives to the low fire position. Once the mod motor reaches the low fire position, the low fire proving switch closes, and actuator feedback input X2-09.4 is energized.
6. If the jumper for direct ignition is not installed, the LME75 progresses through phases 40, 42, and 44 without any change to the mod motor. During these phases, the LME75 lights off the pilot and establishes a flame signal. The mod motor remains at the low fire position, and actuator feedback input X2-09.4 is required to remain energized during these phases, proving that the mod motor is at the low fire position through the light-off sequence.
7. Main valve outputs X7-04.4 and X7-02.3 are energized in phase 50 (for piloted burners) or phase 40 (for non-piloted burners). Input X5-03.3 is energized, which has no effect. Output X2-09.3 is de-energized, so normally open contact CR-1B remains open, and relay CR-2 remains de-energized. The mod motor remains at the low fire position. The LME75 lights off the main burner and progresses through the end of phase 52 like this.
8. The LME75 transitions to operation phase oP. During phase oP, power on input X5-03.3 is directly transmitted to output X2-09.3, causing relay CR-1 to energize. Normally open contact CR-1B closes, energizing relay CR-2. Normally open contact CR-2 closes, allowing the modulation signal (0-135 Ohm or 4-20 mA) to control the mod motor. Normally closed contact CR-2 opens, preventing the connection of terminals R and B on 0-135 Ohm mod motors or terminals F and - on 4-20 mA mod motors. During phase oP, the mod motor is controlled by an external control signal, and the LME75 does not require any type of position feedback.
9. The LME75 loses the call for heat and transitions to phase oP1. Output X2-09.2 is energized to drive the mod motor to low fire before shutting the fuel valves. Once the mod motor reaches the low fire position, the low fire proving switch closes, and actuator feedback input X2-09.4 is energized.
10. Postpurge (phase 74) occurs at low fire. No outputs are energized that would allow the mod motor to move off of low fire. No actuator position feedback is required during postpurge.

Honeywell Modutrol IV with the LME75 (continued)

11. Output X2-09.1 is energized in phase 10 to drive the mod motor to low fire. Since the mod motor is already at the low fire position, the low fire proving switch is closed, and actuator feedback input X2-09.4 is energized.

12. The LME75 transitions to standby, displayed as “OFF” on the LME75 and AZL23.

PME75.811A1 Phase Diagram with Relays

	Terminal	Description	Notes	LOC	OFF	21	22	24	22	30	36	40	42	44	50	52	oP	oP1	70	72	74	10	80	81	82	83	
				Param.				259		225	260	257				230	231	232	240	212			234		242	243	244
				STARTUP												OPERATION				SHUTDOWN				VALVE PROVING			
				SAFETY TIME 1																							
INPUTS	X3-04.5	Main Voltage																									
	X3-04.1	Safety Loop		X	X																						
	X5-03.1	Burner On			M																						
	X3-02.1	Air Pressure Switch	Note 3			X			M																		
	X5-01.2	Gas Pressure Switch(es)	Note 4																								
	X9-04.2	Valve Proving Pressure Switch																									
	X10-05.1 X10-06.2	Flame Signal			X					X	X																
	X2-02.4	POC (P237.00 = 1, P237.01 = 0) POC (P237.00 = 2, P237.01 = 0) High Gas Press. Sw. (P237.01 = 1)														X											
OUTPUTS	X2-02.3	POC Source		X	X																						
	X6-03.3	Safety Valve		X	X																						
	X2-01.3	Blower		X	X	X																					
	X4-02.3	Ignition Transformer		X	X	X	X	X	X	X	X	X	X	X	X	X	X	X	X	X	X	X	X	X	X	X	
	X7-01.3	Pilot Valve	Note 1	X	X	X	X	X	X	X	X	X	X	X	X	X	X	X	X	X	X	X	X	X	X	X	
	X7-04.4	Main Valve V1	Note 1	X	X	X	X	X	X	X	X	X	X	X	X	X	X	X	X	X	X	X	X	X	X	X	
	X7-02.3	Main Valve V2		X	X	X	X	X	X	X	X	X	X	X	X	X	X	X	X	X	X	X	X	X	X	X	
X2-03.3	Alarm			X	X	X	X	X	X	X	X	X	X	X	X	X	X	X	X	X	X	X	X	X	X		
ACTUATOR	X2-09.3	Drive to High Fire		X	X	X	X	X	X	X	X	X	X	X	X	X	X	X	X	X	X	X	X	X	X	X	
	X2-09.2	Drive to Ignition / Low Fire		X	X	X	X	X	X	X	X	X	X	X	X	X	X	X	X	X	X	X	X	X	X	X	
	X2-09.1	Drive Closed		X	X	X	X	X	X	X	X	X	X	X	X	X	X	X	X	X	X	X	X	X	X	X	
	X2-09.4	Position Feedback				M		M		M								M					M				
RELAYS	CR-1	Drive to High Fire		X	X	X	X	X	X	X	X	X	X	X	X	X	X	X	X	X	X	X	X	X	X	X	
	CR-2	Release to Modulate		X	X	X	X	X	X	X	X	X	X	X	X	X	X	X	X	X	X	X	X	X	X	X	
	CR-3	Drive to Low Fire		X	X	X	X	X	X	X	X	X	X	X	X	X	X	X	X	X	X	X	X	X	X	X	
	CR-4	Main Valve V2	Note 1	X	X	X	X	X	X	X	X	X	X	X	X	X	X	X	X	X	X	X	X	X	X	X	

Legend : Energized X De-energized
 Energized or de-energized M Must be energized by end of phase

Two Flame Detectors

Introduction

When using a piloted line burner with a flame propagating in excess of three feet, two flame detectors are required by both NFPA 86 and CSA B149.3. These flame detectors are:

1. Ignition flame detector – used to sense the pilot burner flame at the source of ignition
2. Propagation flame detector – used to sense the main burner flame at the farthest point from the source of ignition

The following procedure and wiring diagrams describe how to connect two flame detectors to a single LME7 burner control and how to use a timer relay to switch between the two flame detectors.

Procedure and Notes

1. An on-delay timer relay is required for this application. Set the timer relay for a time that is shorter than parameter 231 (pilot and main overlap time), but longer than the time it takes to light the main burner.
2. Wire the timer relay and flame detectors according to the appropriate wiring diagram on the following pages.
3. When main valve terminal X7-04.4 is energized in phase 50, the timer relay will energize. Once the preset time has elapsed, the normally open relay contact(s) will close and the normally closed relay contact(s) will open. This will cause the switchover from the ignition flame detector to the propagation flame detector.
4. When using two flame scanners on the LME75, one flame scanner must be a QRA75.A17 and the other flame scanner must be a 5002-01... series scanner from Preferred Instruments.
5. On the following wiring diagrams, the ignition flame detector and propagation flame detector can be switched if desired. For example, if the diagram shows a flame rod as the ignition flame detector and a flame scanner as the propagation flame detector, it is also okay to use the flame rod as the propagation flame detector and a flame scanner as the ignition flame detector. To do so, simply wire the normally closed and normally open timer relay contacts reverse of what the wiring diagram shows.

Two Flame Detectors (continued)

Wiring Diagrams

Two Flame Rods (Any LME7)

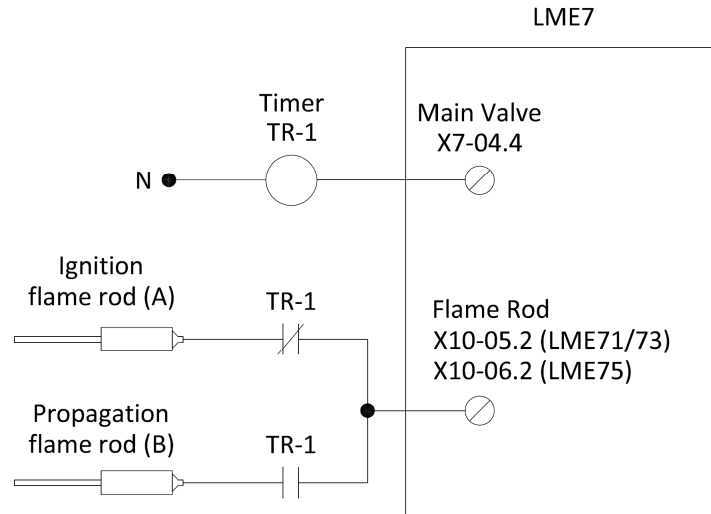

Two Flame Scanners (LME71/73)

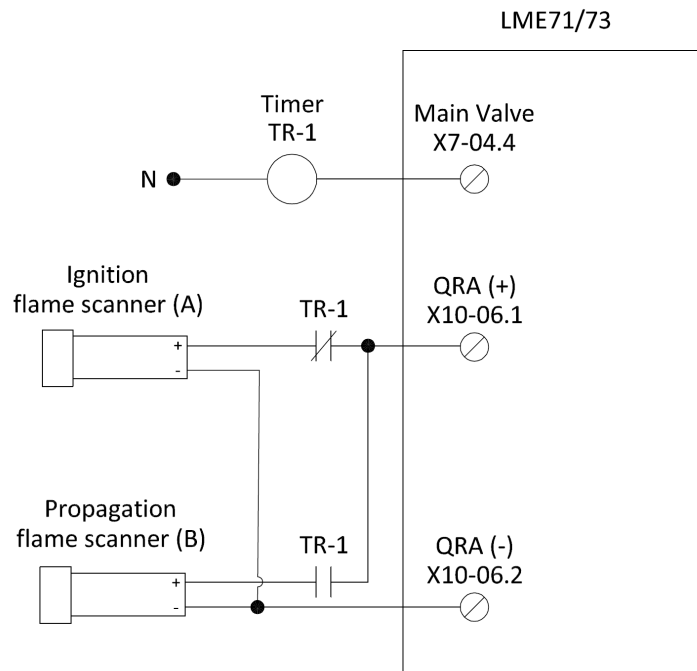

Two Flame Detectors (continued)

Two Flame Scanners (LME75)

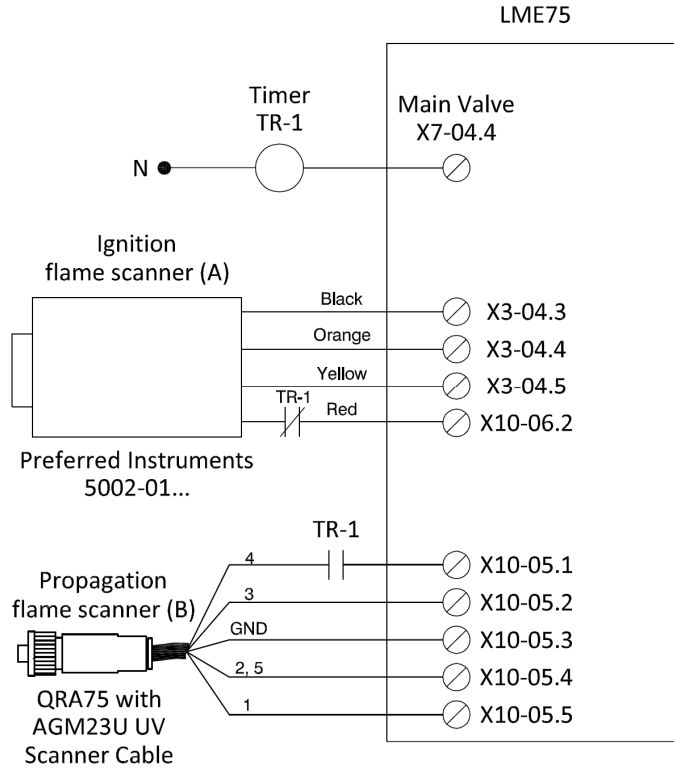

One Flame Rod and One Flame Scanner (LME71/73)

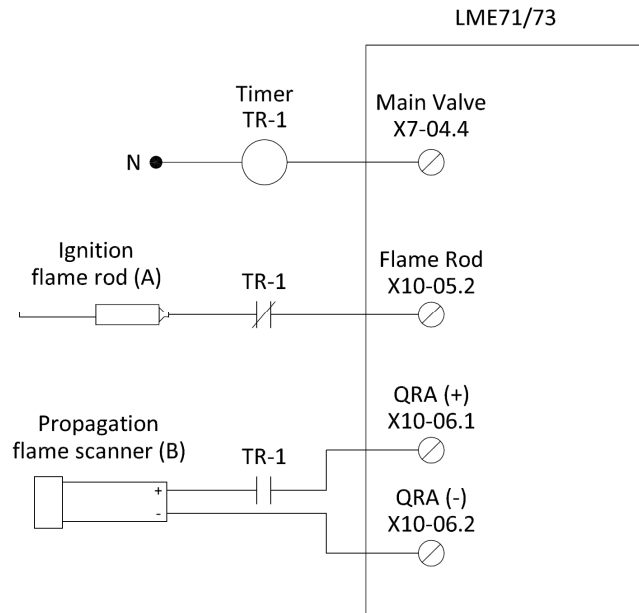

Two Flame Detectors (continued)

One Flame Rod and One Flame Scanner (LME75)

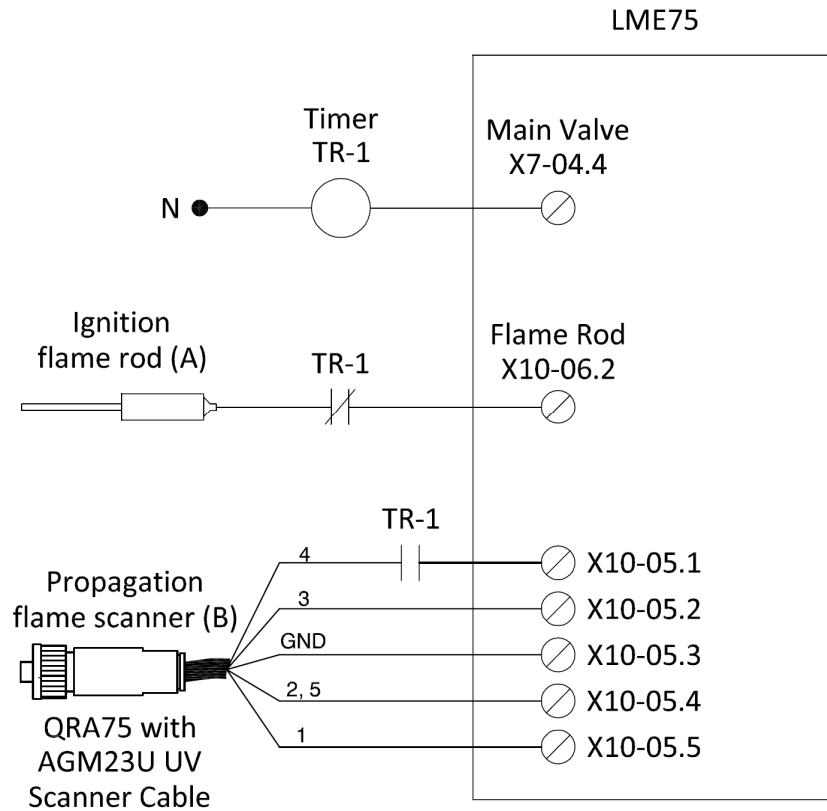

Intentionally Left Blank

Technical Instructions LME-1000
June 11, 2019

SCC, Inc.
1250 Lunt Avenue
Elk Grove Village, IL 60007
USA
Telephone: 1-224-366-8445
www.scccombustion.com

