

Gas Pressure Regulator RL – RLH Serie 1/2" - 2"

Main Features

Direct-acting RL Serie Gas Pressure Regulators According to EN88-1 and EN88-2



- Fail Open regulator
- Balanced valve
- Rugged construction for durability
- Wide pressure regulation range
- Full seal at zero flow
- Easy maintenance
- Optional minimum and/or maximum pressure slam-shut device
- Optional Internal Relief Valve for outdoor version

Technical Features

Maximum allowable pressure –PS	RL 0.5 bar EN 88-1 RLH 0.5 – 2 bar EN88-2
Inlet pressure range –bPu	RL Pa+20mbar – 0.5 bar RLH 0.5 – 2 bar
Outlet pressure range –P2 or Pa	RL 10 – 350 mbar RLH 15 – 350 mbar
Allowable temperature –TS ⁽¹⁾	-20 °C to +60 °C
Inlet gas temperature	-20 °C to +60 °C
Accuracy class –AC	Pa up to 150mbar AC10 Pa up to 350 mbar AC 5
Lock-up pressure class –SG	Pa up to 150mbar AC30 Pa up to 350 mbar SG 10
Nominal size –DN	1/2" 3/4" 1" 1 1/4" 1 1/2" 2"
Connections	Threaded Rp EN or NPT ASME

⁽¹⁾ Low temperature version -40°C: available on request

Metarials

Body	Aluminium
Covers	Aluminium
Seat	Brass
Internal Parts	Stainless steel and brass
Seals	NBR EN549
Diaphragm	NBR EN549

Gas Pressure Regulator, RL / RLH Serie

Standards and certificates

Applied directives:

Pressure Equipment Directive –PED

(EU) EU/2014/68



Compliance with the regulations of the applied directives is verified by the adherence to the following standards / regulations:

- Pressure regulators for inlet pressures up to and including 50 kPa EN 88-1
- Pressure regulators for inlet pressures above 50 kPa up to and including 500 kPa EN 88-2
- EU Desing Examination Certificate EN334:2019



- UkrSepro Tecnical Regulations for Pressure Equipment UA.TR.012C.0368



The relevant valid edition of the standards can be found in the declaration of conformity!

Use

General Gases :

Natural gas, town gas, propane, butane, air, nitrogen or all non-corrosive gases

Suitable for use with previously filtered gaseous fluids, it is mainly used for medium and low pressure natural gas systems.

Hydrogen Ready :

Suitability of natural gas-hydrogen mixtures or pure hydrogen.

When using the R series, a manufacturer's declaration and notified body reports can be provided on request.

Biogas or Biomethane Version :

Suitable for biogases and recycling gases

– up to maximum 1% by volume H₂S, dry

– up to maximum 1% by volume NH₃,

dry No non-ferrous metals (except in very small quantities found in the plastic components)

Biogas version of R Series are also designed for slightly aggressive, dry gases.

Gases according such as biogases, landfill gases, sewage gases, other recycled gases, process gases, and air. The chemical composition and aggressiveness of each biogas or recycled gas is different, not constant, and dependent on several factors.

The aggressiveness of the gas notably increases:

- as the hydrogen sulfide content H₂S increases

- with the moisture content of the gas, condensation is not permitted inside the regulator

In consultation with Gastech, users must decide whether the materials used for the RL or RLH Series are suitable for the intended types of recycling gas. These gases can vary in terms of both their composition and the respective concentration of the components.

As a result, it is not possible to make any warranties or definitive statements regarding service life. An assessment should be carried out to determine the suitability of the gas used.



For safety reasons, we strongly recommend

- the installation of a safety relief Valve and SSV device

- a visual inspection of the R Serie regulator at intervals of 3 to 6 months

- Function and leakage tests

Gas Pressure Regulator, RL / RLH Serie

**Desing,
 Operational Diagram**

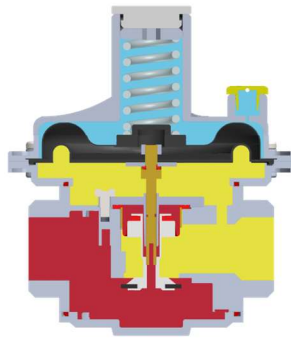
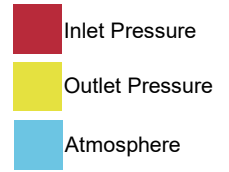

Gas Pressure Regulator

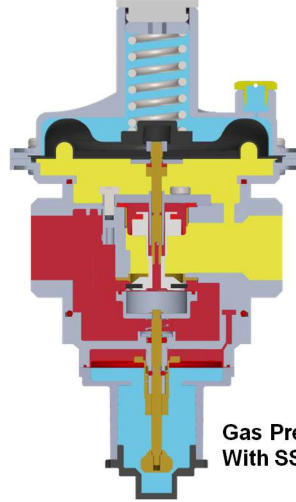

Gas Pressure Regulator
 With SSV

Configurations

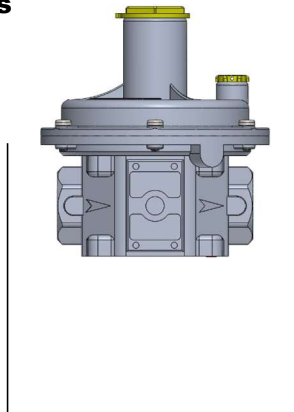

Gas Pressure Regulator
 RL-RLH 15-20-25

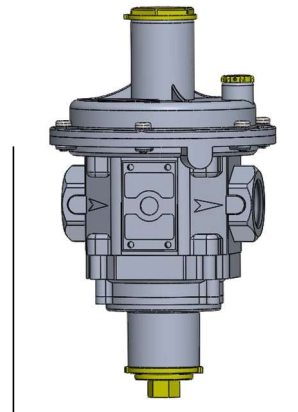

Gas Pressure Regulator
 with Slam Shut Valve
 RL-RLH/S 15-20-25

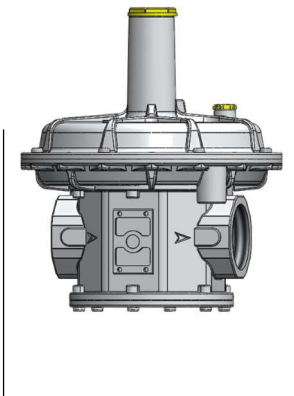

Gas Pressure Regulator
 RL-RLH 32-40-50

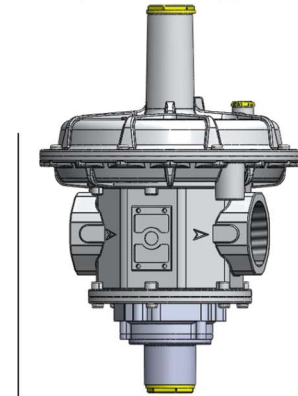

Gas Pressure Regulator
 with Slam Shut Valve
 RL-RLH/S 32-40-50

Gas Pressure Regulator, RL / RLH Serie

Slum Shut Valve

The RL or RLH series of regulators can be fitted with safety shut-off valve for overpressure (OPSO) or combined under-and-over pressure (UPS/O/PSO) protection. Shutoff gas flow when the outlet pressure of the regulator increases or/and decreases. The Slum shut valve trip pressure can easily be adjusted independently of the regulator set point. Built internal bypass, for balancing pressure before relatching the safety shut-off valve, is operated by pulling the valve stem. Possibility of application of devices for remote signal and remote control.

Technical Features

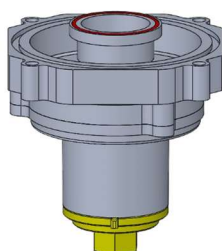

Type	IS
Operation class	A
Response time	< 2 s
Allowable temperature –TS ⁽¹⁾	-20 °C to +60 °C
Accuracy –AG ⁽²⁾	up to AG 10
Set Range OPSO ⁽³⁾	BP 20 - 500mbar
Set Range OPSO ⁽³⁾	BP 15 -3000mbar

⁽¹⁾ Low temperature version -40°C: available on request

⁽²⁾ Depending on working conditions

⁽³⁾ change different springs Refer to page 6

Monitor Unit

The Monitor or emergency regulator is used as a safety device in gas pressure reduction systems. The purpose of this device is to protect the system against possible overpressure, while keeping the reduction line in service.

Monitor regulator is generally installed upstream of the active regulator. Although the function of the monitor regulator is different, the two regulators are virtually identical from the point of view of their mechanical components. Flow coefficients of the regulator puls line monitor system are about 15% lower than those of the active regulator alone.

In normal operation of a wide-open configuration, the working regulator controls the system's outlet pressure. With a higher outlet pressure setting, the monitor regulator senses a pressure lower than its setpoint and tries to increase outlet pressure by going wide open. If the working regulator fails, the monitoring regulator assumes control and holds the outlet pressure at its outlet pressure setting.

Internal Relief Valve

R series can be equipped with an incorporated internal relief valve (SRV) that discharges a limited amount of gas into the atmosphere when the regulator outlet pressure exceeds the set value.

If the outlet pressure rises for any reason, discharge to the atmosphere starts. The discharge stops when the outlet pressure drops to the normal level.

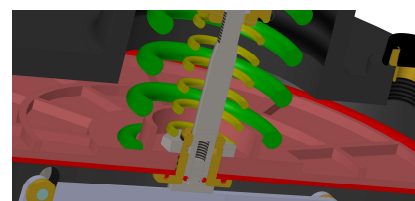

 The discharge outlet must be transported to a safe open environment via a pipe.

Gas Pressure Regulator, RL / RLH Serie
Capacity Tables
RL - RLH 15 – 1/2" x 1/2"

Inlet pressure (mbar)	Outlet Pressure (mbar)					
	20	30	50	100	200	300
50	16	16	-	-	-	-
100	19	22	18	-	-	-
200	26	26	27	28	-	-
300	29	29	30	35	33	-
500	30	32	32	40	48	52
1000	28	38	52	63	88	101
2000	32	39	52	63	89	102

RL - RLH 20 – 3/4" x 3/4"

Inlet pressure (mbar)	Outlet Pressure (mbar)					
	20	30	50	100	200	300
50	23	24	-	-	-	-
100	42	42	43	-	-	-
200	58	58	62	58	-	-
300	75	77	79	79	52	-
500	75	77	102	102	81	82
1000	42	50	72	103	102	103
2000	51	56	69	103	103	103

RL - RLH 25 – 1" x 1"

Inlet pressure (mbar)	Outlet Pressure (mbar)					
	20	30	50	100	200	300
50	30	28	-	-	-	-
100	48	50	44	-	-	-
200	72	73	73	58	-	-
300	86	88	88	89	51	-
500	103	103	105	95	90	90
1000	103	105	105	105	106	106
2000	103	105	105	105	106	106

Gas Pressure Regulator, RL / RLH Serie
Capacity Tables
RL - RLH 32 – 11/4" x 11/4"

Inlet pressure (mbar)	Outlet Pressure (mbar)					
	20	30	50	100	200	300
50	58	42	-	-	-	-
100	98	92	83	-	-	-
200	160	160	150	140	-	-
300	190	195	195	170	110	-
500	260	265	270	245	185	185
1000	420	420	430	415	330	315
2000	425	480	520	600	540	610

RL - RLH 40 – 11/2" x 11/2"

Inlet pressure (mbar)	Outlet Pressure (mbar)					
	20	30	50	100	200	300
50	59	46	-	-	-	-
100	100	98	91	-	-	-
200	160	160	155	140	-	-
300	190	195	195	180	110	-
500	275	280	280	270	220	180
1000	400	415	415	420	350	350
2000	615	615	640	675	620	620

RL - RLH 50 – 2" x 2"

Inlet pressure (mbar)	Outlet Pressure (mbar)					
	20	30	50	100	200	300
50	60	55	-	-	-	-
100	105	105	95	-	-	-
200	160	160	165	140	-	-
300	210	210	205	195	120	-
500	280	280	275	270	200	210
1000	450	450	455	440	400	400
2000	705	710	710	720	720	700

Gas Pressure Regulator, RL / RLH Serie

Dimensions and Weights

RL - RLH Serie -without SSV

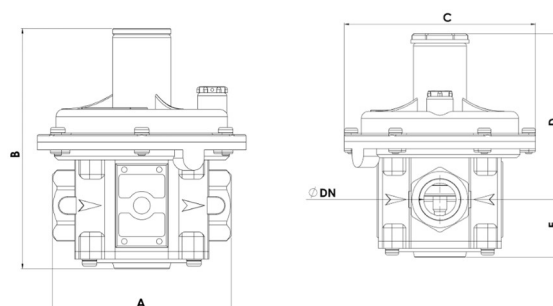

DN	A	B	C	D	E
Rp. 1/2"	120	165	140	122	42
Rp. 3/4"	120	165	140	122	42
Rp. 1"	120	165	140	122	42
Rp. 1 1/4"	160	260	225	197	64
Rp. 1 1/2"	160	260	225	197	64
Rp. 2"	160	260	225	197	64

RL - RLH Serie -with SSV

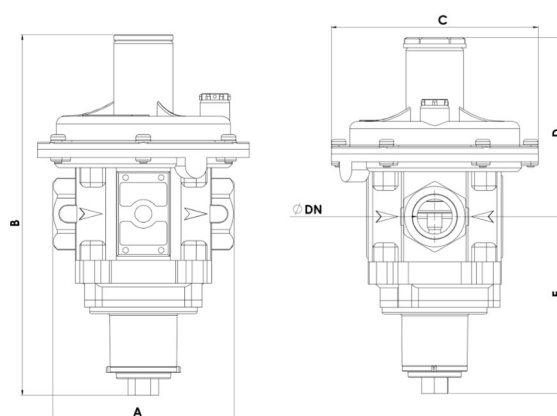

DN	A	B	C	D	E
Rp. 1/2"	120	242	140	122	120
Rp. 3/4"	120	242	140	122	120
Rp. 1"	120	242	140	122	120
Rp. 1 1/4"	160	347	225	197	150
Rp. 1 1/2"	160	347	225	197	150
Rp. 2"	160	347	225	197	150

Gas Pressure Regulator, RL / RLH Serie

Correction factor for non-natural gas applications

The flow rates are indicated for a 0.6 specific gravity gas. To determine the volumetric flow rate for gases other than natural gas, multiply or calculate the values in the capacity tables using the sizing equations with a correction factor. The table below lists correction factors for some common gases:

Gas Type	Density ratio to air	Conversion factor
Air	1.00	0.77
Butane	2.00	0.55
Propane	1.52	0,63
Propane+Air Mix	1.2	0,71
Hydrogen	0.07	2.94
Nitrogen	0.97	0.79
Carbondioxide	1.52	0.63

Use the following formula to calculate the correction factor for gases not listed above. In the formula, d is the specific gravity of the gas.

$$\text{Conversion factor} = \sqrt{\frac{0.6}{d}}$$

Stm3 /h /reference conditions 15 °C, 1 barg

Stm3 /h x 0.94795 = Nm3 /h

Nm3 /h reference conditions 0 °C, 1 barg

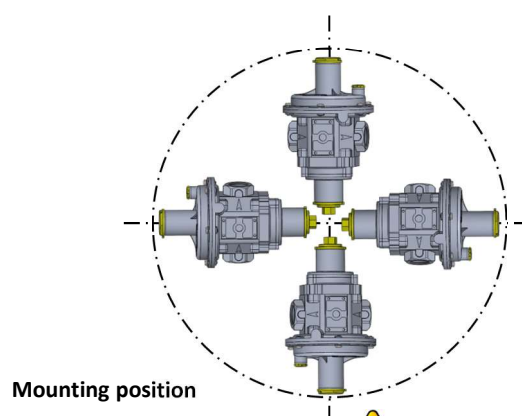

Mounting the regulator upside down will reduce the adjustment range of the outlet pressure by approximately 3 mbar

Gas Pressure Regulator, RL / RLH Serie

Outlet Pressure Range and Setting Springs

The spring setting ranges for RL/RLH 15 – 20 – 25 regulator are shown in the tables below



Pressure Range (mbar)	Actuator (∅)	Color		Diameter (mm)	Order Code
10 – 20	120 BP	Grey		1.5	2.16.0058
15 – 30	120 BP	Yellow		1.6	2.16.0059
30 – 110	120 BP	Blue		2.2	2.16.0029
100 – 150	120 BP	Black		2.5	2.16.0053
150 – 320	120 BP	Orange		3.5	2.16.0031

The spring setting ranges for RL/RLH 32 – 40 – 50 regulator are shown in the tables below

Pressure Range (mbar)	Actuator (∅)	Color		Diameter (mm)	Order Code
10 – 30	220 BP	Grey		2.2	2.16.9001
30 – 50	220 BP	Yellow		2.5	2.16.9002
40 – 60	220 BP	Blue		2.5	2.16.9003
60 – 90	220 BP	Black		3.2	2.16.9004
90 – 190	220 BP	Orange		3.5	2.16.9005
190 - 320	220 BP	Red		4.0	2.16.9006

Shut Off Range and Setting Springs

Over- Shut off setting ranges for the RL/RLH all diameters are shown in the tables below

Pressure Range (mbar)	Actuator (∅)	Color		Diameter (mm)	Order Code
20 – 50	120 BP-MP	Red		2.2	2.16.9007
30 – 80	120 BP-MP	Blue		2.5	2.16.9008
50 – 200	120 BP-MP	Yellow		2.8	2.16.9009
190 – 400	120 BP-MP	Black		3.2	2.16.9010





Gas Pressure Regulator, RL / RLH Serie

Color of Products

Standard Colors Natural Aluminium

Optional Colors

You can choose one or more of the following colors.

Part	RAL Code	Color
All Parts	1021	
All Parts	3000	
All Parts	9005	
All Parts	6011	
All Parts	5010	

 delivery times and price may vary in optional color options.

Gas Pressure Regulator, RL / RLH Serie

NOTES

For more information, contact your local sales representative or agency.



info@gastech.com.tr



www.gastech.com.tr



+90 286 501 55 11



gastech_naturalgas



www.linkedin.com/in/gastech-naturalgas-577b931a8/

GASTECH SANAYI VE TICARET ANONIM SİRKETİ
Çanakkale Organize Sanayi Bölgesi, 1. Cadde No:28 17100
Merkez-Çanakkale-TURKEY
Chamber of Commerce Çanakkale, 9492
www.gastech.com.tr info@gastech.com.tr

All rights reserved. 01/2023.

The Gastech logo is a trademark and service mark of GASTECH AS. All other marks are the property of their prospective owners. Gastech™ is a mark owned by one of the companies in the GASTECH AS. Subject to changes and errors. The information given in this document only contains general descriptions and/or performance features which may not always specifically reflect those described, or which may undergo modification in the course of further development of the products. The requested performance features are binding only when they are expressly agreed upon in the concluded contract. GASTECH AS does not assume responsibility for the selection, use or maintenance of any product. Responsibility for proper selection, use and maintenance of any product remains solely with the purchaser.